

SYSMAC

CS Series

CS1W-PTS□□/PTW□□/PDC□□/PTR□□/

PPS□□/

PMV□□

CJ Series

CJ1W-PTS□□/PDC□□/PH41U

Analog I/O Units

OPERATION MANUAL

OMRON

CS Series

**CS1W-PTS□□/PTW□□/PDC□□/PTR□□/
PPS□□/PMV□□**

CJ Series

CJ1W-PTS□□/PDC□□/PH41U

Analog I/O Units

Operation Manual

Revised March 2008

Notice:

OMRON products are manufactured for use according to proper procedures by a qualified operator and only for the purposes described in this manual.

The following conventions are used to indicate and classify precautions in this manual. Always heed the information provided with them. Failure to heed precautions can result in injury to people or damage to property.

 **DANGER** Indicates an imminently hazardous situation which, if not avoided, will result in death or serious injury. Additionally, there may be severe property damage.

 **WARNING** Indicates a potentially hazardous situation which, if not avoided, could result in death or serious injury. Additionally, there may be severe property damage.

 **Caution** Indicates a potentially hazardous situation which, if not avoided, may result in minor or moderate injury, or property damage.

OMRON Product References

All OMRON products are capitalized in this manual. The word “Unit” is also capitalized when it refers to an OMRON product, regardless of whether or not it appears in the proper name of the product.

The abbreviation “Ch,” which appears in some displays and on some OMRON products, often means “word” and is abbreviated “Wd” in documentation in this sense.

The abbreviation “PLC” means Programmable Controller. “PC” is used, however, in some Programming Device displays to mean Programmable Controller.

Visual Aids

The following headings appear in the left column of the manual to help you locate different types of information.

Note Indicates information of particular interest for efficient and convenient operation of the product.

1,2,3... 1. Indicates lists of one sort or another, such as procedures, checklists, etc.

© OMRON, 2000

All rights reserved. No part of this publication may be reproduced, stored in a retrieval system, or transmitted, in any form, or by any means, mechanical, electronic, photocopying, recording, or otherwise, without the prior written permission of OMRON.

No patent liability is assumed with respect to the use of the information contained herein. Moreover, because OMRON is constantly striving to improve its high-quality products, the information contained in this manual is subject to change without notice. Every precaution has been taken in the preparation of this manual. Nevertheless, OMRON assumes no responsibility for errors or omissions. Neither is any liability assumed for damages resulting from the use of the information contained in this publication.

TABLE OF CONTENTS

| | |
|---|-------------|
| PRECAUTIONS | xvii |
| 1 Intended Audience | xviii |
| 2 General Precautions | xviii |
| 3 Safety Precautions | xviii |
| 4 Operating Environment Precautions | xix |
| 5 Application Precautions | xx |
| 6 Conformance to EC Directives | xxii |

SECTION 1

| | |
|---|----------|
| Overview and Features | 1 |
| 1-1 Overview of Analog I/O Units | 2 |
| 1-2 Features and Functions | 7 |
| 1-3 System Configuration | 24 |
| 1-4 Specifications and Installation | 26 |
| 1-5 Operating Procedures | 55 |
| 1-6 Error Processing | 57 |
| 1-7 Specification Changes | 61 |

SECTION 2

| | |
|---|-----------|
| Individual Unit Descriptions for CS Series | 67 |
| 2-1 CS1W-PTS01-V1 Isolated-type Thermocouple Input Unit | 68 |
| 2-2 CS1W-PTS11 Isolated-type Thermocouple Input Unit | 80 |
| 2-3 CS1W-PTS51 Isolated-type Thermocouple Input Unit | 97 |
| 2-4 CS1W-PTS55 Isolated-type Thermocouple Input Unit | 109 |
| 2-5 CS1W-PTS02 Isolated-type Resistance Thermometer Input Unit (Pt100 or JPt100) | 121 |
| 2-6 CS1W-PTS03 Isolated-type Resistance Thermometer Input Unit (Ni508.4) | 132 |
| 2-7 CS1W-PTS12 Isolated-type Resistance Thermometer Input Unit (Pt100, JPt100, Pt50, Ni508.4) | 142 |
| 2-8 CS1W-PTS52 Isolated-type Resistance Thermometer Input Unit (Pt100, JPt100) | 157 |
| 2-9 CS1W-PTS56 Isolated-type Resistance Thermometer Input Unit (Pt100, JPt100) | 167 |
| 2-10 CS1W-PTW01 2-Wire Transmitter Input Unit | 177 |
| 2-11 CS1W-PDC01 Isolated-type Direct Current Input Unit | 189 |
| 2-12 CS1W-PDC11 Isolated-type Direct Current Input Unit | 200 |
| 2-13 CS1W-PDC55 Isolated-type Direct Current Input Unit | 218 |
| 2-14 CS1W-PTR01 Power Transducer Input Unit | 229 |
| 2-15 CS1W-PTR02 Analog Input Unit (100 mV) | 238 |
| 2-16 CS1W-PPS01 Isolated-type Pulse Input Unit | 247 |
| 2-17 CS1W-PMV01 Isolated-type Analog Output Unit | 258 |
| 2-18 CS1W-PMV02 Isolated-type Analog Output Unit | 267 |

TABLE OF CONTENTS

SECTION 3

Individual Unit Descriptions for CJ Series 275

| | | |
|-----|---|-----|
| 3-1 | CJ1W-PTS51 Isolated-type Thermocouple Input Unit | 276 |
| 3-2 | CJ1W-PTS15 Isolated-type Thermocouple Input Unit | 288 |
| 3-3 | CJ1W-PTS52 Isolated-type Resistance Thermometer Input Unit (Pt100, JPt100). | 302 |
| 3-4 | CJ1W-PTS16 Isolated-type Resistance Thermometer Input Unit (Pt100, JPt100, Pt50, Ni508.4) | 312 |
| 3-5 | CJ1W-PDC15 Isolated-type Direct Current Input Unit | 324 |
| 3-6 | CJ1W-PH41U Isolated-type Universal Input Unit | 338 |

Appendices

| | | |
|---|--|-----|
| A | Supplementary Explanation of Functions | 365 |
| B | Zero/Span Adjustment Example | 375 |

Index 379

Revision History 383

About this Manual:

This manual describes the installation and operation of the CS/CJ-series Analog I/O Units and includes the sections described below.

In this manual, “Analog I/O Units” is a product group name for the following groups of Units.

| | Name | Model number |
|----------------------------------|---|---------------|
| CS-series | Isolated-type Thermocouple Input Unit | CS1W-PTS01-V1 |
| | | CS1W-PTS11 |
| | | CS1W-PTS51 |
| | | CS1W-PTS55 |
| | Isolated-type Resistance Thermometer Input Unit (Pt100 or JPt100) | CS1W-PTS02 |
| | Isolated-type Resistance Thermometer Input Unit (Ni508.4) | CS1W-PTS03 |
| | Isolated-type Resistance Thermometer Input Unit (Pt100, JPt100, Pt50, or Ni508.4) | CS1W-PTS12 |
| | Isolated-type Resistance Thermometer Input Unit (Pt100, JPt100) | CS1W-PTS52 |
| | | CS1W-PTS56 |
| | Isolated-type 2-Wire Transmitter Input Unit | CS1W-PTW01 |
| | Isolated-type Direct Current Input Unit | CS1W-PDC01 |
| | | CS1W-PDC11 |
| | | CS1W-PDC55 |
| | Power Transducer Input Unit | CS1W-PTR01 |
| Analog Input Unit | CS1W-PTR02 | |
| Isolated-type Pulse Input Unit | CS1W-PPS01 | |
| Isolated-type Analog Output Unit | CS1W-PMV01/PMV02 | |
| CJ-series | Isolated-type Thermocouple Input Unit | CJ1W-PTS51/15 |
| | Isolated-type Resistance Thermometer Input Unit (Pt100, JPt100) | CJ1W-PTS52 |
| | Isolated-type Resistance Thermometer input (Pt100, JPt100, Pt50 or Ni508.4) | CJ1W-PTS16 |
| | Isolated-type Direct Current Input Unit | CJ1W-PDC15 |
| | Isolated-type Universal Input Unit | CJ1W-PH41U |

Please read this manual carefully and be sure you understand the information provided before attempting to install and operate the Analog I/O Units.

Section 1 presents an overview of the CS/CJ-series Analog I/O Units, and outlines their common features.

Section 2 describes each of the CS-series Analog I/O Units in detail.

Section 3 describes each of the CJ-series Analog I/O Units in detail.

Appendix A provides a supplementary explanation of Unit functions.

Appendix B provides an example of zero/span adjustment.

 **WARNING** Failure to read and understand the information provided in this manual may result in personal injury or death, damage to the product, or product failure. Please read each section in its entirety and be sure you understand the information provided in the section and related sections before attempting any of the procedures or operations given.

Related Manuals

The following table describes the CS/CJ-series manuals that are related to the Analog I/O Units.

| Cat. No. | Model | Manual name | Application | Contents |
|--------------------|---|---|--|--|
| W368 (this manual) | CS1W-PTS□□/ PTW□□/PTC□□/ PTR□□/PPS□□/ PMV□□ CJ1W-PTS□□/ PDC□□/PH41U | CS/CJ-series Analog I/O Units Operation Manual | Information on using the Analog I/O Units. | Provides information on using the CS/CJ-series Analog Input, Analog Output, and Analog I/O Units. |
| W339 | CS1G/H-CPU□□H, CS1G/H-CPU□□-EV1 | SYSMAC CS-series PLCs Operation Manual | Basic CS-series PLC information, includ- ing an overview, design, installation, and maintenance. | Provides the following information on CS-series PLCs: <ul style="list-style-type: none"> • Overview and features • System configuration design • Installation and wiring • I/O memory allocations • Troubleshooting |
| W405 | CS1D-CPU□□H, CS1D-CPU□□S, CS1D-DPL01, CS1D- PA207R | SYSMAC CS-series Duplex System Oper- ation Manual | Basic information and procedures for CS-series Duplex Systems. | Provides an outline of and describes the design, installation, maintenance, and other basic oper- ations for a Duplex System based on CS1D CPU Units. |
| W393 | CJ1H-CPU□□H-R CJ1G/H-CPU□□H CJ1G-CPU□□P CJ1G-CPU□□ CJ1H-CPU□□ | CJ-series PLCs Operation Manual | Basic CJ-series PLC information, includ- ing an overview, design, installation, and maintenance. | Provides the following information on CJ-series PLCs: <ul style="list-style-type: none"> • Overview and features • System configuration design • Installation and wiring • I/O memory allocations • Troubleshooting |
| W394 | CS1G/H-CPU□□H CS1G/H-CPU□□-V1 CS1D-CPU□□H CS1D-CPU□□S CJ1H-CPU□□H-R CJ1G/H-CPU□□H CJ1G-CPU□□P CJ1M-CPU□□ CJ1G-CPU□□ NSJ□-□□□□(B)-G5D NSJ□-□□□□(B)-M3D | CS/CJ/NSJ-series PLCs Programming Manual | Information on the operation of CS/CJ/ NSJ-series PLCs. | Provides the following information on CS/CJ/NSJ-series PLCs: <ul style="list-style-type: none"> • Programming • Task functions • File memory • Various operations |
| W340 | CS1G/H-CPU□□H CS1G/H-CPU□□-V1 CS1D-CPU□□H CS1D-CPU□□S CJ1H-CPU□□H-R CJ1G/H-CPU□□H CJ1G-CPU□□P CJ1M-CPU□□ CJ1G-CPU□□ NSJ□-□□□□(B)-G5D NSJ□-□□□□(B)-M3D | CS/CJ/NSJ-series PLCs Instructions Reference Manual | Detailed information on instructions. | Describe all the ladder program- ming instructions in detail. |

| Cat. No. | Model | Manual name | Application | Contents |
|-----------------|--|---|---|--|
| W446 | WS02-CXPC1-EV7 | CX-Programmer Operation Manual (Version 7.□) | Information on using the CX-Programmer (programming soft- ware for a personal computer running Windows). | Describes how to use the CX-Pro- grammer. |
| W341 | CQM1H-PRO01 CQM1-PRO01 C200H-PRO27 + CS1W-KS001 | CS/CJ-series Pro- gramming Console Operation Manual | Information on using the Programming Console. | Describes how to use the Program- ming Console. |

Read and Understand this Manual

Please read and understand this manual before using the product. Please consult your OMRON representative if you have any questions or comments.

Warranty and Limitations of Liability

WARRANTY

OMRON's exclusive warranty is that the products are free from defects in materials and workmanship for a period of one year (or other period if specified) from date of sale by OMRON.

OMRON MAKES NO WARRANTY OR REPRESENTATION, EXPRESS OR IMPLIED, REGARDING NON-INFRINGEMENT, MERCHANTABILITY, OR FITNESS FOR PARTICULAR PURPOSE OF THE PRODUCTS. ANY BUYER OR USER ACKNOWLEDGES THAT THE BUYER OR USER ALONE HAS DETERMINED THAT THE PRODUCTS WILL SUITABLY MEET THE REQUIREMENTS OF THEIR INTENDED USE. OMRON DISCLAIMS ALL OTHER WARRANTIES, EXPRESS OR IMPLIED.

LIMITATIONS OF LIABILITY

OMRON SHALL NOT BE RESPONSIBLE FOR SPECIAL, INDIRECT, OR CONSEQUENTIAL DAMAGES, LOSS OF PROFITS OR COMMERCIAL LOSS IN ANY WAY CONNECTED WITH THE PRODUCTS, WHETHER SUCH CLAIM IS BASED ON CONTRACT, WARRANTY, NEGLIGENCE, OR STRICT LIABILITY.

In no event shall the responsibility of OMRON for any act exceed the individual price of the product on which liability is asserted.

IN NO EVENT SHALL OMRON BE RESPONSIBLE FOR WARRANTY, REPAIR, OR OTHER CLAIMS REGARDING THE PRODUCTS UNLESS OMRON'S ANALYSIS CONFIRMS THAT THE PRODUCTS WERE PROPERLY HANDLED, STORED, INSTALLED, AND MAINTAINED AND NOT SUBJECT TO CONTAMINATION, ABUSE, MISUSE, OR INAPPROPRIATE MODIFICATION OR REPAIR.

Application Considerations

SUITABILITY FOR USE

OMRON shall not be responsible for conformity with any standards, codes, or regulations that apply to the combination of products in the customer's application or use of the products.

At the customer's request, OMRON will provide applicable third party certification documents identifying ratings and limitations of use that apply to the products. This information by itself is not sufficient for a complete determination of the suitability of the products in combination with the end product, machine, system, or other application or use.

The following are some examples of applications for which particular attention must be given. This is not intended to be an exhaustive list of all possible uses of the products, nor is it intended to imply that the uses listed may be suitable for the products:

- Outdoor use, uses involving potential chemical contamination or electrical interference, or conditions or uses not described in this manual.
- Nuclear energy control systems, combustion systems, railroad systems, aviation systems, medical equipment, amusement machines, vehicles, safety equipment, and installations subject to separate industry or government regulations.
- Systems, machines, and equipment that could present a risk to life or property.

Please know and observe all prohibitions of use applicable to the products.

NEVER USE THE PRODUCTS FOR AN APPLICATION INVOLVING SERIOUS RISK TO LIFE OR PROPERTY WITHOUT ENSURING THAT THE SYSTEM AS A WHOLE HAS BEEN DESIGNED TO ADDRESS THE RISKS, AND THAT THE OMRON PRODUCTS ARE PROPERLY RATED AND INSTALLED FOR THE INTENDED USE WITHIN THE OVERALL EQUIPMENT OR SYSTEM.

PROGRAMMABLE PRODUCTS

OMRON shall not be responsible for the user's programming of a programmable product, or any consequence thereof.

Disclaimers

CHANGE IN SPECIFICATIONS

Product specifications and accessories may be changed at any time based on improvements and other reasons.

It is our practice to change model numbers when published ratings or features are changed, or when significant construction changes are made. However, some specifications of the products may be changed without any notice. When in doubt, special model numbers may be assigned to fix or establish key specifications for your application on your request. Please consult with your OMRON representative at any time to confirm actual specifications of purchased products.

DIMENSIONS AND WEIGHTS

Dimensions and weights are nominal and are not to be used for manufacturing purposes, even when tolerances are shown.

PERFORMANCE DATA

Performance data given in this manual is provided as a guide for the user in determining suitability and does not constitute a warranty. It may represent the result of OMRON's test conditions, and the users must correlate it to actual application requirements. Actual performance is subject to the OMRON Warranty and Limitations of Liability.

ERRORS AND OMISSIONS

The information in this manual has been carefully checked and is believed to be accurate; however, no responsibility is assumed for clerical, typographical, or proofreading errors, or omissions.

PRECAUTIONS

This section provides general precautions for using the CS/CJ-series Programmable Controllers (PLCs) and related devices.

The information contained in this section is important for the safe and reliable application of Programmable Controllers. You must read this section and understand the information contained before attempting to set up or operate a PLC system.

| | | |
|-----|---|-------|
| 1 | Intended Audience | xviii |
| 2 | General Precautions | xviii |
| 3 | Safety Precautions | xviii |
| 4 | Operating Environment Precautions..... | xix |
| 5 | Application Precautions | xx |
| 6 | Conformance to EC Directives..... | xxii |
| 6-1 | Applicable Directives..... | xxii |
| 6-2 | Concepts..... | xxii |
| 6-3 | Conformance to EC Directives | xxiii |
| 6-4 | Conditions for Complying with EC Directives | xxiii |

1 Intended Audience

This manual is intended for the following personnel, who must also have knowledge of electrical systems (an electrical engineer or the equivalent).

- Personnel in charge of installing FA systems.
- Personnel in charge of designing FA systems.
- Personnel in charge of managing FA systems and facilities.

2 General Precautions

The user must operate the product according to the performance specifications described in the operation manuals.

Before using the product under conditions which are not described in the manual or applying the product to nuclear control systems, railroad systems, aviation systems, vehicles, combustion systems, medical equipment, amusement machines, safety equipment, and other systems, machines, and equipment that may have a serious influence on lives and property if used improperly, consult your OMRON representative.

Make sure that the ratings and performance characteristics of the product are sufficient for the systems, machines, and equipment, and be sure to provide the systems, machines, and equipment with double safety mechanisms.

This manual provides information for programming and operating the Unit. Be sure to read this manual before attempting to use the Unit and keep this manual close at hand for reference during operation.





 **WARNING** It is extremely important that a PLC and all PLC Units be used for the specified purpose and under the specified conditions, especially in applications that can directly or indirectly affect human life. You must consult with your OMRON representative before applying a PLC System to the above-mentioned applications.

3 Safety Precautions



 **WARNING** Do not attempt to take any Unit apart while the power is being supplied. Doing so may result in electric shock.

 **WARNING** Provide safety measures in external circuits (i.e., not in the Programmable Controller), including the following items, to ensure safety in the system if an abnormality occurs due to malfunction of the PLC or another external factor affecting the PLC operation. Not doing so may result in serious accidents.

- Emergency stop circuits, interlock circuits, limit circuits, and similar safety measures must be provided in external control circuits.
- Unless otherwise stated, the PLC will turn OFF all outputs when its self-diagnosis function detects any error or when a severe failure alarm (FALS) instruction is executed. (The operation of outputs from Analog Output Units is described later in this manual.) As a countermeasure for such errors, external safety measures must be provided to ensure safety in the system. (The external alarm output on the CS1W-PTS51/PTS52, CJ1W-PTS51/PTS52, however, will be ON.)
- The PLC outputs may remain ON or OFF due to deposition or burning of the output relays or destruction of the output transistors. As a countermeasure for such problems, external safety measures must be provided to ensure safety in the system.
- When the 24-VDC output (service power supply to the PLC) is overloaded or short-circuited, the voltage may drop and result in the outputs being turned OFF. As a countermeasure for such problems, external safety measures must be provided to ensure safety in the system.

-  **WARNING** Always turn OFF the power supply to the PLC before attempting any of the following. Not turning OFF the power supply may result in malfunction or electric shock.
- Mounting or dismounting the Power Supply Units, I/O Units, CPU Units, or any other Units.
 - Assembling the Units.
 - Setting DIP switches or rotary switches.
 - Connecting cables or wiring the system.
 - Connecting or disconnecting the connectors.
-  **WARNING** Do not attempt to disassemble, repair, or modify any Units. Any attempt to do so may result in malfunction, fire, or electric shock.
-  **WARNING** Do not apply a voltage or current outside the specified range to any Unit. Doing so may result in malfunction or fire.
-  **Caution** Execute online edit only after confirming that no adverse effects will be caused by extending the cycle time. Otherwise, input signals may not be readable.

4 Operating Environment Precautions

-  **Caution** Do not operate the control system in the following locations:
- Locations subject to direct sunlight.
 - Locations subject to temperatures or humidity outside the range specified in the specifications.
 - Locations subject to condensation as the result of severe changes in temperature.
 - Locations subject to corrosive or flammable gases.
 - Locations subject to dust (especially iron dust) or salts.
 - Locations subject to exposure to water, oil, or chemicals.
 - Locations subject to shock or vibration.
-  **Caution** Take appropriate and sufficient countermeasures when installing systems in the following locations:
- Locations subject to static electricity or other forms of noise.
 - Locations subject to strong electromagnetic fields.
 - Locations subject to possible exposure to radioactivity.
 - Locations close to power supplies.
-  **Caution** The operating environment of the PLC System can have a large effect on the longevity and reliability of the system. Improper operating environments can lead to malfunction, failure, and other unforeseeable problems with the PLC System. Be sure that the operating environment is within the specified conditions at installation and remains within the specified conditions during the life of the system.

- ⚠ Caution** When connecting a personal computers or other peripheral devices to a PLC to which a non-insulated Power Supply Unit (CJ1W-PD022) is mounted, either ground the 0 V side of the external power supply or do not ground the external power supply at all ground. A short-circuit will occur in the external power supply if incorrect grounding methods are used. Never ground the 24 V side, as shown below.

Wiring in Which the 24-V Power Supply Will Short

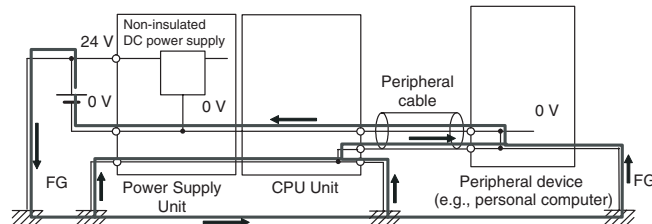

- ⚠ Caution** Do not connect a Relay Contact Output Unit in the same CPU Rack or Expansion Rack as the CJ1W-PH41U Isolated-type Universal Input Unit. Doing so may cause the process values to be abnormal, resulting in unexpected operation in machinery or equipment.

5 Application Precautions

Observe the following precautions when using the Analog I/O Unit.

- If any one of cold junction compensating elements is disconnected, no compensation will be performed, resulting in improper temperature measurement. Do not disconnect cold junction compensating elements. (Applicable to the CS1W-PTS01-V1, PTS11/PTS51/PTS55, CJ1W-PTS51/PTS15 Isolated-type Thermocouple Input Unit or CJ1W-PH41U Isolated-type Universal Input Unit.)
- Each cold junction compensation element is calibrated for the individual Unit and connected circuit; do not use elements from other Units or replace two elements of the same Unit. Doing so will result in improper temperature measurement. Use elements attached at the time of product delivery. (Applicable to the CS1W-PTS01-V1, PTS11/PTS51/PTS55, CJ1W-PTS51/PTS15 Isolated-type Thermocouple Input Unit or CJ1W-PH41U Isolated-type Universal Input Unit.)
- If the external 24-V power supply for the CJ1W-PTS15/PTS16 or CJ1W-PDC15 drops below the specified voltage range, the Power Supply Flag will turn OFF, the Sensor Error Flag will turn ON, and the conversion data will be fixed at the upper limit or lower limit values. Prevent this effect on the control system operation by using these flags in the input data read conditions or implement other measures in the user program.
- When using the CS1W-PTS15/PTS16 or CS1W-PDC15, make sure that the external 24-VDC power supply is isolated.
- Check the user program for proper execution before actually running it on the Unit. Not checking the program may result in an unexpected operation.
- Fail-safe measures must be taken by the customer to ensure safety in the event of incorrect, missing, or abnormal signals caused by broken signal lines, momentary power interruptions, or other causes.
- Install a breaker or take other safety measures against short-circuiting of external wiring.
- Confirm that no adverse effect will occur in the system before attempting any of the following. Not doing so may result in an unexpected operation.
 - Changing the operating mode of the PLC (including the setting of the startup operating mode).

- Force-setting/force-resetting any bit in memory.
- Changing the present value of any word or any set value in memory.
- Be sure that all the mounting screws, terminal screws, and cable connector screws are tightened to the torque specified in this manual. Incorrect tightening torque may result in malfunction.
- Be sure that the terminal blocks, expansion cables, and other items with locking devices are properly locked into place. Improper locking may result in malfunction.
- Take appropriate measures to ensure that the specified power with the rated voltage and frequency is supplied in places where the power supply is unstable. An incorrect power supply may result in malfunction.
- Leave the label attached to the Unit when wiring. Removing the label may result in malfunction if foreign matter enters the Unit.
- Remove the label after the completion of wiring to ensure proper heat dissipation. Leaving the label attached may result in malfunction.
- Use crimp terminals for wiring. Do not connect bare stranded wires directly to terminals. Connection of bare stranded wires may result in burning.
- Be sure to use the power supply voltage specified in this manual.
- Do not apply voltages to the input section in excess of the rated input voltage. Excess voltages may result in burning.
- Do not apply voltages or connect loads to the output section in excess of the maximum switching capacity. Excess voltage or loads may result in burning.
- Double-check all wiring, switch settings, and data memory (DM) settings before turning ON the power supply. Incorrect wiring may result in burning.
- Resume operation only after transferring to the new CPU Unit the contents of the DM Area, HR Area, and other data required for resuming operation. Not doing so may result in an unexpected operation.
- Do not drop the product or subject it to excessive vibration or shock.
- Touch a grounded piece of metal to discharge static electricity from your body before touching a Unit.
- Check the terminal block completed before mounting it.
- Install circuit breakers or take other countermeasures against short-circuits in external wiring.
- Install Units as far as possible away from devices that generate strong, high-frequency noise.
- Check to be sure that all switches and memory contents, such as the DIP Switches and the contents of the DM Area) are correct before starting operation.
- Do not pull on cables or bend them past their natural bending radius.
- Do not place any objects on top of cables.
- When wiring crossovers between terminals, the total current for both terminals will flow in the line. Check the current capacities of all wires before wiring crossovers.
- The following precautions apply to Power Supply Units with Replacement Notification.
 - When the LED display on the front of the Power Supply Unit starts to alternately display “0.0” and “A02” or the alarm output automatically turns OFF, replace the Power Supply Unit within 6 months.
 - Separate the alarm output cables from power lines and high-voltage lines.

- Do not apply a voltage or connect a load to the alarm output that exceeds the rated voltage or load.
- Maintain an ambient storage temperature of –20 to 30°C and humidity of 25% to 70% when storing the product for longer than 3 months to keep the replacement notification function in optimum working condition.
- Always use the standard installation method. A nonstandard installation will decrease heat dissipation, delay the replacement notification signal, and may degrade or damage the internal elements.
- Design the system so that the power supply capacity of the Power Supply Unit is not exceeded.
- Do not touch the terminals on the Power Supply Unit immediately after turning OFF the power supply. Electric shock may occur due to the residual voltage.
- The product is EMC compliant when assembled in a complete PLC system of the specified PLC series. For earthing, selection of cable, and any other conditions for EMC compliance, refer the manual for installation.
- This is a class A product. In residential areas it may cause radio interference, in which case the user may be required to take adequate measures to reduce interference.

6 Conformance to EC Directives

6-1 Applicable Directives

- EMC Directives
- Low Voltage Directive

6-2 Concepts

EMC Directives

OMRON devices that comply with EC Directives also conform to the related EMC standards so that they can be more easily built into other devices or the overall machine. The actual products have been checked for conformity to EMC standards (see the following note). Whether the products conform to the standards in the system used by the customer, however, must be checked by the customer.

EMC-related performance of the OMRON devices that comply with EC Directives will vary depending on the configuration, wiring, and other conditions of the equipment or control panel on which the OMRON devices are installed. The customer must, therefore, perform the final check to confirm that devices and the overall machine conform to EMC standards.

Note Applicable EMC (Electromagnetic Compatibility) standards are as follows:

EMS (Electromagnetic Susceptibility): EN61000-6-2

EMI (Electromagnetic Interference): EN61000-6-4

(Radiated emission: 10-m regulations)

Low Voltage Directives

Always ensure that devices operating at voltages of 50 to 1,000 V AC and 75 to 1,500 V DC meet the required safety standards for the PLC (EN61131-2).

6-3 Conformance to EC Directives

The CS/CJ-series PLCs comply with EC Directives. To ensure that the machine or device in which a CS/CJ-series PLC is used complies with EC Directives, the PLC must be installed as follows:

- The CS/CJ-series PLC must be installed within a control panel.
- You must use reinforced insulation or double insulation for the DC power supplies used for the communications power supply and I/O power supplies.
- CS/CJ-series PLCs complying with EC Directives also conform to the Common Emission Standard (EN61000-6-4). Radiated emission characteristics (10-m regulations) may vary depending on the configuration of the control panel used, other devices connected to the control panel, wiring, and other conditions. You must therefore confirm that the overall machine or equipment complies with EC Directives.

6-4 Conditions for Complying with EC Directives

The following condition was used in the immunity test of the CS1W-PTS11/PTS12, PDC11, CJ1W-PTS15/PTS16, CJ1W-PDC15 and CJ1W-PH41U Analog I/O Units.

- Standard accuracy: $\pm 5\%$

The following conditions were used in the immunity test of the CS1W-PTS51/PTS52/PTS55/PTS56, PDC55 and CJ1W-PTS51/PTS52.

| | | |
|------------|---|--|
| CS1W-PTS51 | R or S thermocouple | $\pm 1\%$ of PV or $\pm 10^\circ\text{C}$, whichever is larger, ± 1 digit |
| CS1W-PTS55 | K, J, T, or L thermocouple | $\pm 1\%$ of PV or $\pm 4^\circ\text{C}$, whichever is larger, ± 1 digit |
| CJ1W-PTS51 | | |
| CS1W-PTS52 | $\pm 1\%$ of PV or $\pm 2^\circ\text{C}$, whichever is larger, ± 1 digit | |
| CS1W-PTS56 | | |
| CJ1W-PTS52 | | |
| CS1W-PDC55 | $\pm 1\%$ of FS max. | |

SECTION 1

Overview and Features

This section presents an overview of the CS/CJ-series Analog I/O Units and outlines their features.

| | | |
|-------|--|----|
| 1-1 | Overview of Analog I/O Units | 2 |
| 1-1-1 | CS-series Analog I/O Units | 2 |
| 1-1-2 | CJ-series Analog I/O Units | 5 |
| 1-2 | Features and Functions | 7 |
| 1-3 | System Configuration | 24 |
| 1-4 | Specifications and Installation | 26 |
| 1-4-1 | Specifications | 26 |
| 1-4-2 | Nomenclature and Functions | 28 |
| 1-4-3 | Exchanging Data with the CPU Unit | 34 |
| 1-4-4 | Mounting the Units | 48 |
| 1-4-5 | Precautions when Handling Units | 50 |
| 1-4-6 | Connecting Crimp Terminals | 52 |
| 1-4-7 | Dimensions | 52 |
| 1-5 | Operating Procedures | 55 |
| 1-6 | Error Processing | 57 |
| 1-7 | Specification Changes | 61 |
| 1-7-1 | CS1W-PTS01-V1, CS1W-PTS02/PTS03, CS1W-PTW01, CS1W-PDC01, CS1W-PPS01, and CS1W-PMV01 | 61 |
| 1-7-2 | CS1W-PTS51/PTS52 and CJ1W-PTS51/PTS52 | 63 |
| 1-7-3 | CS1W-PTS55 and CS1W-PDC55 | 64 |

1-1 Overview of Analog I/O Units

1-1-1 CS-series Analog I/O Units

There are 18 Analog I/O Unit models, as shown in the following table.

| Name | Model | Number of I/O | Resolution | Conversion period | Field I/O isolation | I/O type | Main functions |
|---|---------------|---------------|------------|--|--------------------------|---|--|
| Isolated-type Thermocouple Input Unit | CS1W-PTS01-V1 | 4 inputs | 1/4,096 | 150 ms/ 4 inputs | All inputs are isolated. | <ul style="list-style-type: none"> Thermocouple: B, E, J, K, N, R, S, T, mV | <ul style="list-style-type: none"> Variable range setting Process value scaling Process value alarm Mean value processing Rate-of-change calculation and alarm Alarm-ON delay Disconnection detection |
| | CS1W-PTS11 | 4 inputs | 1/64,000 | 20 ms/ 4 inputs 10 ms/ 2 inputs | All inputs are isolated. | <ul style="list-style-type: none"> Thermocouple: B, E, J, K, L, N, R, S, T, U, WRe5-26, PL II DC voltage: ±100 mV | <ul style="list-style-type: none"> Variable range setting Process value scaling Process value alarm Mean value processing Rate-of-change calculation and alarm Alarm-ON delay Disconnection detection Adjustment period control Peak and bottom values Top and valley values Zero/span adjustment |
| | CS1W-PTS51 | 4 inputs | --- | 250 ms/ 4 inputs | All inputs are isolated. | <ul style="list-style-type: none"> Thermocouple: B, J, K, L, R, S, T | <ul style="list-style-type: none"> Process value alarm (with external alarm) Sensor error detection Alarm-ON delay Zero/span adjustment |
| | CS1W-PTS55 | 8 inputs | --- | 250 ms/ 8 inputs | All inputs are isolated. | <ul style="list-style-type: none"> Thermocouple: B, J, K, L, R, S, T | <ul style="list-style-type: none"> Process value alarm Sensor error detection Alarm-ON delay Zero/span adjustment |
| Isolated-type Resistance Thermometer Input Unit (Pt100, JPt100) | CS1W-PTS02 | 4 inputs | 1/4,096 | 100 ms/ 4 inputs | All inputs are isolated. | <ul style="list-style-type: none"> Resistance thermometer: Pt100 (JIS, IEC), JPt100 | <ul style="list-style-type: none"> Variable range setting Process value scaling Process value alarm Mean value processing Rate-of-change calculation and alarm Alarm-ON delay Disconnection detection |
| Isolated-type Resistance Thermometer Input Unit (Ni508.4) | CS1W-PTS03 | 4 inputs | 1/4,096 | 100 ms/ 4 inputs | All inputs are isolated. | <ul style="list-style-type: none"> Resistance thermometer: Ni508.4 | <ul style="list-style-type: none"> Variable range setting Process value scaling Process value alarm Mean value processing Rate-of-change calculation and alarm Alarm-ON delay Disconnection detection |

| Name | Model | Number of I/O | Resolution | Conversion period | Field I/O isolation | I/O type | Main functions |
|--|------------|---------------|------------|--|--------------------------|--|--|
| Isolated-type Resistance Thermometer Input Unit (Pt100, JPt100, Pt50, Ni508.4) | CS1W-PTS12 | 4 inputs | 1/64,000 | 20 ms/ 4 inputs 10 ms/ 2 inputs | All inputs are isolated. | <ul style="list-style-type: none"> Resistance thermometer: Pt100, JPt100, Pt50, Ni508.4 | <ul style="list-style-type: none"> Variable range setting Process value scaling Process value alarm Mean value processing Rate-of-change calculation and alarm Alarm-ON delay Disconnection detection Adjustment period control Peak and bottom values Top and valley values Zero/span adjustment |
| Isolated-type Resistance Thermometer Input Unit (Pt100, JPt100) | CS1W-PTS52 | 4 inputs | --- | 250 ms/ 4 inputs | All inputs are isolated. | <ul style="list-style-type: none"> Resistance thermometer: Pt100 (JIS, IEC), JPt100 | <ul style="list-style-type: none"> Process value alarm (with external alarm) Sensor error detection Alarm-ON delay Zero/span adjustment |
| Isolated-type Resistance Thermometer Input Unit (Pt100, JPt100) | CS1W-PTS56 | 8 inputs | --- | 250 ms/ 8 inputs | All inputs are isolated. | <ul style="list-style-type: none"> Resistance thermometer: Pt100 (JIS, IEC), JPt100 | <ul style="list-style-type: none"> Process value alarm Sensor error detection Alarm-ON delay Zero/span adjustment |
| Isolated-type 2-Wire Transmitter Input Unit | CS1W-PTW01 | 4 inputs | 1/4,096 | 100 ms/ 4 inputs | All inputs are isolated. | 4 to 20 mA from 2-wire transmitter. <ul style="list-style-type: none"> DC current: 4 to 20 mA DC voltage: 1 to 5 V | <ul style="list-style-type: none"> Built-in power supply for 2-wire transmitter Process value scaling Process value alarm Mean value processing Rate-of-change calculation and alarm Alarm-ON delay Input error detection |

| Name | Model | Number of I/O | Resolution | Conversion period | Field I/O isolation | I/O type | Main functions |
|---|------------|---------------|------------|--|-----------------------------|---|--|
| Isolated-type Direct Current Input Unit | CS1W-PDC01 | 4 inputs | 1/4,096 | 100 ms/ 4 inputs | All inputs are isolated. | <ul style="list-style-type: none"> DC voltage: -10 to 10 V, 0 to 10 V, -5 to 5 V, 0 to 5 V, 1 to 5 V, ±10 V user-set range DC current: 4 to 20 mA, 0 to 20 mA | <ul style="list-style-type: none"> Process value scaling Square root Process value alarm Mean value processing Rate-of-change calculation and alarm Alarm-ON delay Input error detection |
| | CS1W-PDC11 | 4 inputs | 1/64,000 | 20 ms/ 4 inputs 10 ms/ 2 inputs | All inputs are isolated. | <ul style="list-style-type: none"> DC voltage: 0 to 1.25 V, -1.25 to 1.25 V, 0 to 5 V, 1 to 5 V, -5 to 5 V, -10 to 10 V, 0 to 10 V, ±10 V user-set DC current: 0 to 20 mA, 4 to 20 mA | <ul style="list-style-type: none"> Variable range setting Process value scaling Square root Mean value processing Rate-of-change calculation and alarm Alarm-ON delay Input error detection Adjustment period control Peak and bottom values Top and valley values Zero/span adjustment Integral value calculation |
| | CS1W-PDC55 | 8 inputs | 1/16,000 | 250 ms/ 8 inputs | All inputs are isolated. | <ul style="list-style-type: none"> DC voltage: 0 to 5 V, 1 to 5 V, 0 to 10 V DC current: 4 to 20 mA | <ul style="list-style-type: none"> Process value scaling Square root Process value alarm Input error detection |
| Power Transducer Input Unit | CS1W-PTR01 | 8 inputs | 1/4,096 | 200 ms/ 8 inputs | No isolation between inputs | <ul style="list-style-type: none"> Input from a power transducer: -1 to 1 mA, 0 to 1 mA | <ul style="list-style-type: none"> Anti-overshooting at motor startup Square root Process value alarm Inrush input limit Alarm-ON delay Mean value processing |
| Analog Input Unit (100 mV) | CS1W-PTR02 | 8 inputs | 1/4,096 | 200 mA/ 8 inputs | No isolation between inputs | <ul style="list-style-type: none"> DC voltage: -100 to 100 mV, 0 to 100 mV | <ul style="list-style-type: none"> Process value scaling Process value alarm Inrush input limit Alarm-ON delay Mean value processing |
| Isolated-type Pulse Input Unit | CS1W-PPS01 | 4 inputs | --- | 100 mA/ 4 inputs | All inputs are isolated. | <ul style="list-style-type: none"> No-voltage semiconductor input: 0 to 20,000 pulses/s Voltage input: 0 to 20,000 pulses/s Contact input: 0 to 20 pulses/s | <ul style="list-style-type: none"> Sensor power supply: 12 V DC, built-in Instantaneous value scaling Mean value processing Instantaneous value alarm Alarm-ON delay Accumulated value output |

| Name | Model | Number of I/O | Resolution | Conversion period | Field I/O isolation | I/O type | Main functions |
|----------------------------------|---|---------------|------------|-------------------|---------------------------|--|---|
| Isolated-type Analog Output Unit | CS1W-PMV01 | 4 outputs | 1/4,096 | 100 ms/4 outputs | All outputs are isolated. | <ul style="list-style-type: none"> DC current: 4 to 20 mA DC voltage: 1 to 5 V | <ul style="list-style-type: none"> Output disconnection alarm Answer input Output rate-of-change limit Output high/low limits Output hold when CPU Unit error occurs Output disconnection detection |
| | CS1W-PMV02 | 4 outputs | 1/16,000 | 40 ms/4 outputs | All outputs are isolated. | <ul style="list-style-type: none"> DC voltage: -10 to 10 V, -1 to 1 V | <ul style="list-style-type: none"> Output rate-of-change limit Output high/low limits Output hold when CPU Unit error occurs |
| | | | 1/8,000 | | | <ul style="list-style-type: none"> 0 to 10 V, 0 to 1 V -5 to 5 V | |
| 1/4,000 | <ul style="list-style-type: none"> 0 to 5 V, | | | | | | |

1-1-2 CJ-series Analog I/O Units

There are 6 Analog I/O Unit models, as shown in the following table.

| Name | Model | Number of I/O | Resolution | Conversion period | Field I/O isolation | I/O type | Main functions |
|---|------------|---------------|------------|-------------------|--------------------------|--|---|
| Isolated-type Thermocouple Input Unit | CJ1W-PTS51 | 4 inputs | --- | 250 ms/4 inputs | All inputs are isolated. | <ul style="list-style-type: none"> Thermocouple: B, J, K, L, R, S, T | <ul style="list-style-type: none"> Process value alarm (with external alarm) Sensor error detection Alarm-ON delay Zero/span adjustment |
| | CJ1W-PTS15 | 2 inputs | 1/64000 | 10 ms/2 inputs | All inputs are isolated. | <ul style="list-style-type: none"> Thermocouple: B, E, J, K, L, N, R, S, T, U, WRe5-26, PLII DC voltage: ±100 mV | <ul style="list-style-type: none"> Process value alarm (with external alarm) Alarm-ON delay Sensor error detection Zero/span adjustment External 24-VDC power supply |
| Isolated-type Resistance Thermometer Input Unit (Pt100, JPt100) | CJ1W-PTS52 | 4 inputs | --- | 250 ms/4 inputs | All inputs are isolated. | <ul style="list-style-type: none"> Resistance thermometer: Pt100 (JIS, IEC), JPt100 | <ul style="list-style-type: none"> Process value alarm (with external alarm) Sensor error detection Alarm-ON delay Zero/span adjustment |
| | CJ1W-PTS16 | 2 inputs | 1/64000 | 10 ms/2 inputs | All inputs are isolated. | <ul style="list-style-type: none"> Resistance thermometer: Pt100 (JIS, IEC), JPt100, Pt50, Ni508.4 | <ul style="list-style-type: none"> Process value alarm (with external alarm) Alarm-ON delay Sensor error detection Zero/span adjustment External 24-VDC power supply |

| Name | Model | Number of I/O | Resolution | Conversion period | Field I/O isolation | I/O type | Main functions |
|---|------------|---------------|---|--------------------------|---|---|---|
| Isolated-type Direct Current Input Unit | CJ1W-PDC15 | 2 inputs | 1/64000 | 10 ms/ 2 inputs | All inputs are isolated. | <ul style="list-style-type: none"> DC voltage 0 to 1.25 V, -1.25 to +1.25 V, 0 to 5 V, 1 to 5 V, -5 to +5 V, 0 to 10 V, -10 to +10 V, ±10 V user set range DC current 0 to 20 mA 4 to 20 mA | <ul style="list-style-type: none"> Variable range setting Process value scaling Square root processing Mean value processing Rate-of-change calculation and alarm Alarm-ON delay Input error detection Adjustment period control Peak and bottom detection Top and valley detection Zero/span adjustment Integral value calculation External 24-VDC power supply |
| Isolated-type Universal Input Unit | CJ1W-PH41U | 4 inputs | Select from the following three modes: Mode 1: Resolution: 1/256,000 Conversion period: 60 ms/ 4 inputs Mode 2: Resolution: 1/64,000 Conversion period: 10 ms/ 4 inputs Mode 3: Resolution: 1/16,000 Conversion period: 5 ms/ 4 inputs | All inputs are isolated. | <ul style="list-style-type: none"> Resistance thermometer: Pt100 (3-wire), JPt100, Pt1000, Pt100 (4-wire) Thermocouple K, J, T, E, L, U, N, R, S, B, WRe5-26, PLII DC voltage: 1 to 5 V, 0 to 1.25 V, 0 to 5 V, 0 to 10 V, ±100 mV, -1.25 to 1.25 V, -5 to 5 V, -10 to 10 V DC current: 0 to 20 mA, 4 to 20 mA Potentiometer | <ul style="list-style-type: none"> Variable input range setting Process value scaling Offset compensation Process value alarm Rate-of-change calculation and alarm Alarm ON/OFF delay Square root extraction Mean value processing Input error detection Adjustment period control Peak and bottom detection Top and valley detection Zero/span adjustment Integral value calculation | |

1-2 Features and Functions

I/O Isolation

The Analog I/O Units listed below have isolation between inputs or outputs. Therefore sneak circuits do not occur between thermocouples or between the power supply's common voltage inputs, so there is no need to utilize a signal converter to prevent sneak circuits.

| | | |
|------------------|--|---------------------------------------|
| Applicable Units | Isolated-type Thermocouple Input Units | CS1W-PTS01-V1/11/51/55, CJ1W-PTS51/15 |
| | Isolated-type Resistance Thermometer Input Units | CS1W-PTS02/03/12/52/56, CJ1W-PTS52/16 |
| | Isolated-type 2-Wire Transmitter Input Unit | CS1W-PTW01 |
| | Isolated-type Direct Current Input Units | CS1W-PDC01/11/55, CJ1W-PDC15 |
| | Isolated-type Pulse Input Unit | CS1W-PPS01 |
| | Isolated-type Analog Output Units | CS1W-PMV01/PMV02 |
| | Isolated-type Universal Input Unit | CJ1W-PH41U |

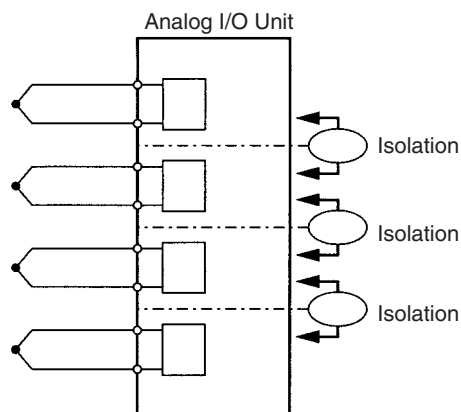

Variable Input Range Setting

For the Analog I/O Units listed below, the input range can be set by the user according to the application. This function applies to the following Units:

| | | |
|------------------|--|------------------------------|
| Applicable Units | Isolated-type Thermocouple Input Units | CS1W-PTS01-V1/11, CJ1W-PTS15 |
| | Isolated-type Resistance Thermometer Input Units | CS1W-PTS02/12, CJ1W-PTS16 |
| | Isolated-type Direct Current Input Units | CS1W-PDC01/11, CJ1W-PDC15 |
| | Isolated-type Universal Input Unit | CJ1W-PH41U |

Note The accuracy and resolution of the CS1W-PTS01-V1, CS1W-PTS02, and CS1W-PDC01 are in respect to the internal ranges.

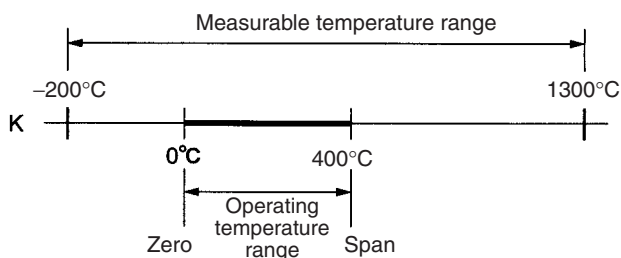

Process Value (or Instantaneous Value) Scaling in Industrial Units

This function takes the value scaled in industrial units with respect to the input signal's zero point and span point, and transfers it to the CPU Unit as the process value. Because of this, no ladder program is required at the CPU Unit for scaling.

Note It also possible to set the process value scaling zero/span point in reverse to create an inverse relationship.

| | | |
|------------------|--|-------------------------------------|
| Applicable Units | Isolated-type Thermocouple Input Units | CS1W-PTS01-V1/11, CJ1W-PTS15 |
| | Isolated-type Resistance Thermometer Input Units | CS1W-PTS02/03/12, CJ1W-PTS16 |
| | Isolated-type 2-Wire Transmitter Input Unit | CS1W-PTW01 |
| | Isolated-type Direct Current Input Unit | CS1W-PDC01/11/55, PTR02, CJ1W-PDC15 |
| | Power Transducer Input Unit | CS1W-PTR01 |
| | Isolated-type Pulse Input Unit | CS1W-PPS01 |
| | Isolated-type Universal Input Unit | CJ1W-PH41U |

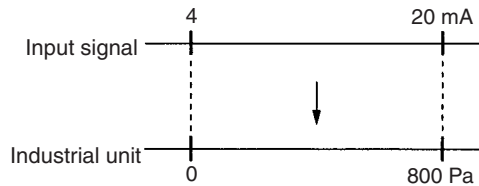

■ **CS1W-PTS11/12, PDC11, CJ1W-PTS15/16, PDC15, PH41U**

With the CS1W-PTS11/PTS12, PDC11, and CJ1W-PTS15/16, PDC15, PH41U, the input range for thermocouple inputs, and platinum-resistance thermometer inputs, or the user-set range for DC inputs can be set directly, and scaling can be set for the range in industrial units. This eliminates the need for processing scaling in the ladder program.

Note It also possible to set the process value scaling zero/span points in reverse to create an inverse relationship.

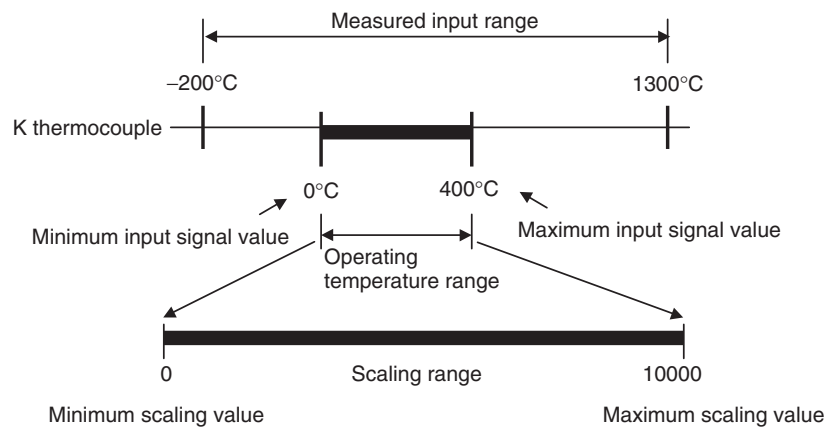

■ **Offset Compensation**

Offset compensation is possible for process value errors. The amount of the error is added to the process value.

| | | |
|------------------|------------------------------------|------------|
| Applicable Units | Isolated-type Universal Input Unit | CJ1W-PH41U |
|------------------|------------------------------------|------------|

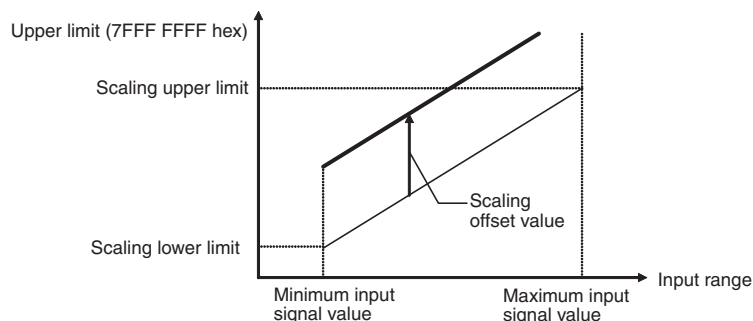

Process Value Alarm

Either a 2-point alarm (H and L limits) or a 4-point alarm (HH, H, L, and LL limits) is possible for the process value (or instantaneous value).

| | | | |
|------------------|---------------|--|----------------------------------|
| Applicable Units | 4-point alarm | Isolated-type Thermocouple Input Units | CS1W-PTS01-V1/11, CJ1W-PTS15 |
| | | Isolated-type Resistance Thermometer Input Units | CS1W-PTS02/03/12, CJ1W-PTS16 |
| | | Isolated-type 2-Wire Transmitter Input Unit | CS1W-PTW01 |
| | | Isolated-type Direct Current Input Units | CS1W-PDC01/11, PTR02, CJ1W-PDC15 |
| | | Isolated-type Pulse Input Unit | CS1W-PPS01 |
| | | Isolated-type Universal Input Unit | CJ1W-PH41U |
| | 2-point alarm | Isolated-type Thermocouple Input Units | CS1W-PTS51/55, CJ1W-PTS51 |
| | | Isolated-type Resistance Thermometer Input Units | CS1W-PTS52/56, CJ1W-PTS52 |
| | | Analog Input Unit (100 mV) | CS1WPTR02, CS1W-PDC55 |
| | | Power Transducer Input Unit | CS1W-PTR01 |

CS1W-PTS51/52 and CJ1W-PTS51/52 Units have one external alarm output for each input. High or low outputs can be selected.

CS1W-PTS55/PTS56 and PDC55 output alarms to the Expansion Setting Area. This enables obtaining alarm outputs without special programming.

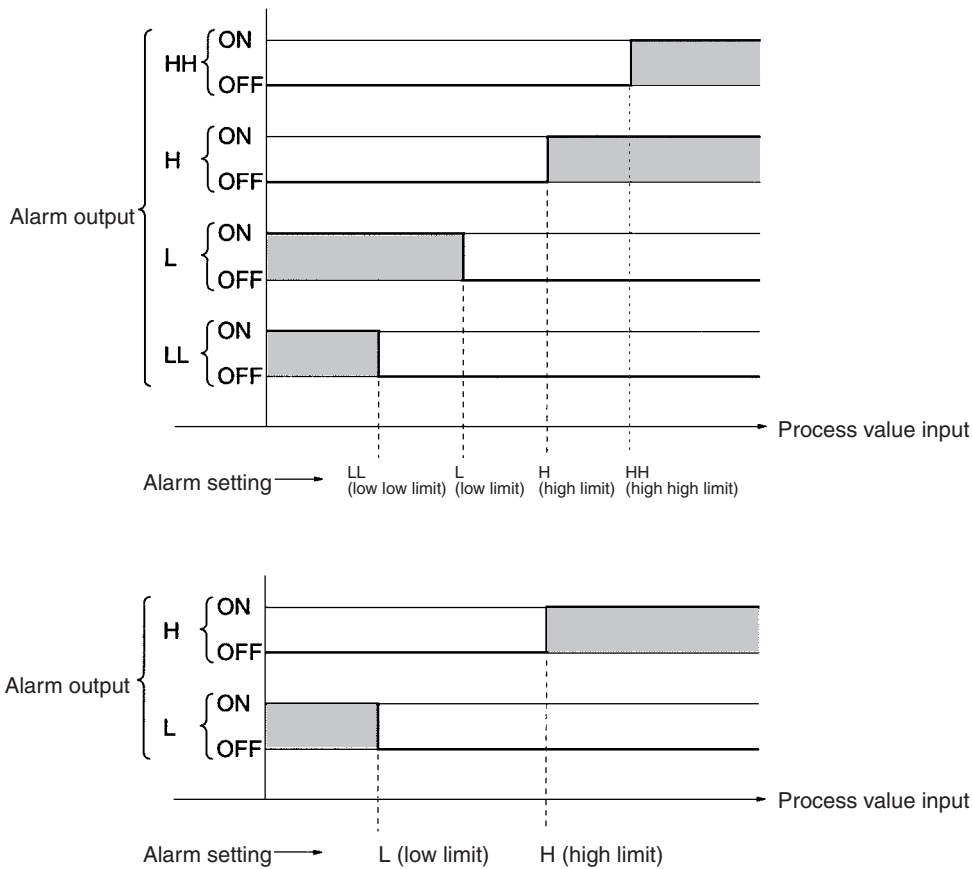

Rate-of-change Calculation and Alarm

The Analog I/O Units listed below calculate the rate of change for the process value, and output an alarm when the high or low limit is exceeded. The rate-of-change value is derived by taking the difference each second between the process value at that time and the process value before the comparison time interval. The comparison time interval can be set from 1 to 16 seconds. This allows even a small process value rate of change to be detected.

| | | |
|------------------|--|------------------------------|
| Applicable Units | Isolated-type Thermocouple Input Units | CS1W-PTS01-V1/11, CJ1W-PTS15 |
| | Isolated-type Resistance Thermometer Input Units | CS1W-PTS02/03/12, CJ1W-PTS16 |
| | Isolated-type 2-Wire Transmitter Input Unit | CS1W-PTW01 |
| | Isolated-type Direct Current Input Units | CS1W-PDC01/11, CJ1W-PDC15 |
| | Isolated-type Universal Input Unit | CJ1W-PH41U |

- Note**
1. With the CJ1W-PH41U, a setting can be made to enable calculating the rate of change each conversion period.
 2. CJ1W-PH41U:
 When the conversion period is 60 ms: 60 to 960 ms
 When the conversion period is 10 ms: 10 to 160 ms
 When the conversion period is 5 ms: 5 to 80 ms

- The rate-of-change value is derived by taking the difference each second between the process value at that time and the process value before the comparison time interval, rather than the difference calculated at each comparison time interval. This allows even a very small process value change to be detected.

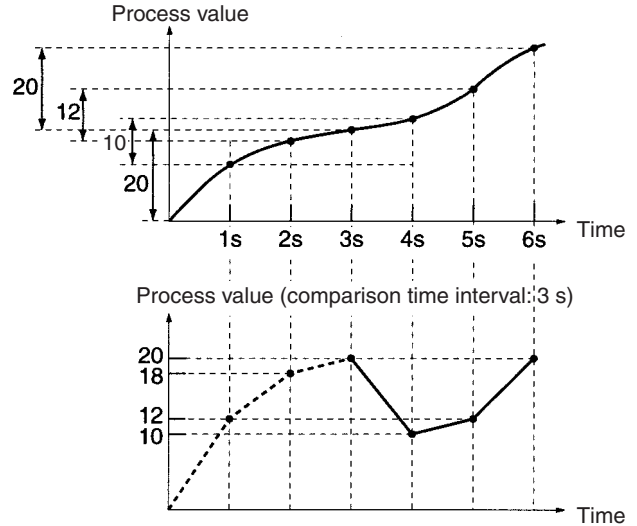
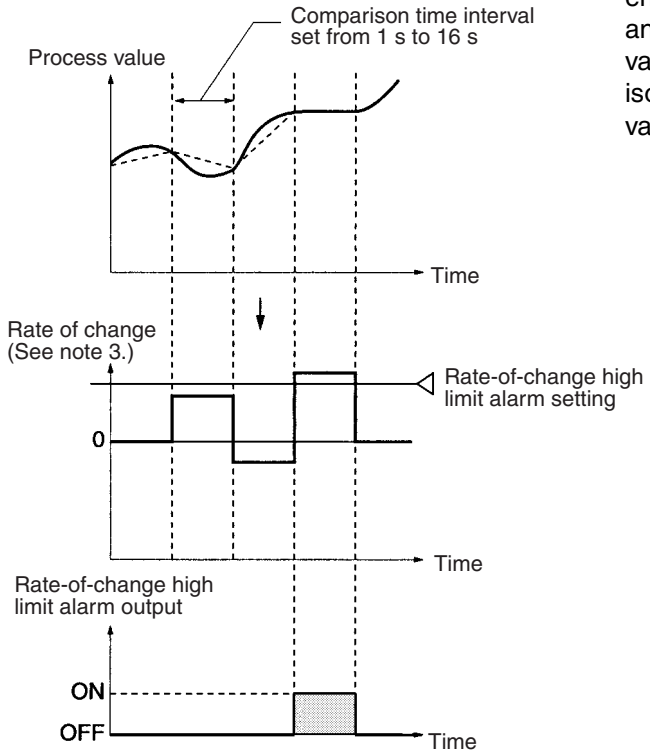

Note The rate of change is calculated every second (and not just once during the comparison time interval) so that even minute changes in the process value are detected.

Alarm Hysteresis

An hysteresis can be set for the process value (or instantaneous value) alarm and the rate-of-change alarm. The operation is as shown in the following diagram.

| | | |
|------------------|--|---------------------------------------|
| Applicable Units | Isolated-type Thermocouple Input Units | CS1W-PTS01-V1/11/51/55, CJ1W-PTS51/15 |
| | Isolated-type Resistance Thermometer Input Units | CS1W-PTS02/03/12/52/56, CJ1W-PTS52/16 |
| | Isolated-type 2-Wire Transmitter Input Unit | CS1W-PTW01 |
| | Isolated-type Direct Current Input Units | CS1W-PDC01/11/55, PTR02, CJ1W-PDC15 |
| | Power Transducer Input Unit | CS1W-PTR01 |
| | Isolated-type Pulse Input Unit | CS1W-PPS01 |
| | Isolated-type Universal Input Unit | CJ1W-PH41U |

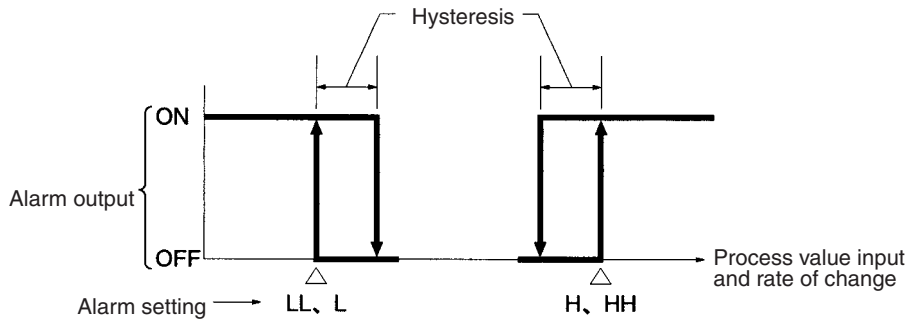

Alarm-ON Delay

This function can be used to set a given time period (0 s to 60 s) for delaying the turning ON of the alarm after the process value (or instantaneous value) alarm status or the alarm setting is reached. One alarm-ON delay is set for each input or output. The same setting is used for all process value alarms (HH, H, L, LL) and rate-of-change alarms (H, L).

| | | |
|------------------|--|---------------------------------------|
| Applicable Units | Isolated-type Thermocouple Input Units | CS1W-PTS01-V1/11/51/55, CJ1W-PTS51/15 |
| | Isolated-type Resistance Thermometer Input Units | CS1W-PTS02/03/12/52/56, CJ1W-PTS52/16 |
| | Isolated-type 2-Wire Transmitter Input Unit | CS1W-PTW01 |
| | Isolated-type Direct Current Input Units | CS1W-PDC01/11/55, PTR02, CJ1W-PDC15 |
| | Power Transducer Input Unit | CS1W-PTR01 |
| | Isolated-type Pulse Input Unit | CS1W-PPS01 |
| | Isolated-type Universal Input Unit | CJ1W-PH41U |

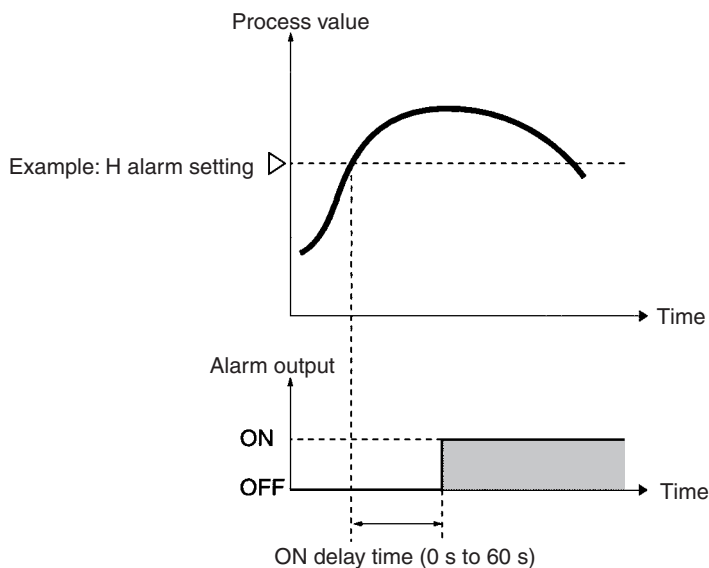

OFF-delay Outputs

This function makes it possible to turn OFF the alarm signal after a set time period (0 to 60 s) has elapsed after alarm status is cleared, rather than having the alarm turned OFF immediately.

An alarm OFF-delay time can be set for each input. The process value alarms (HH, H, L, LL) and rate-of-change alarms (H, L) will all use the same OFF-delay time.

| | | |
|------------------|------------------------------------|------------|
| Applicable Units | Isolated-type Universal Input Unit | CJ1W-PH41U |
|------------------|------------------------------------|------------|

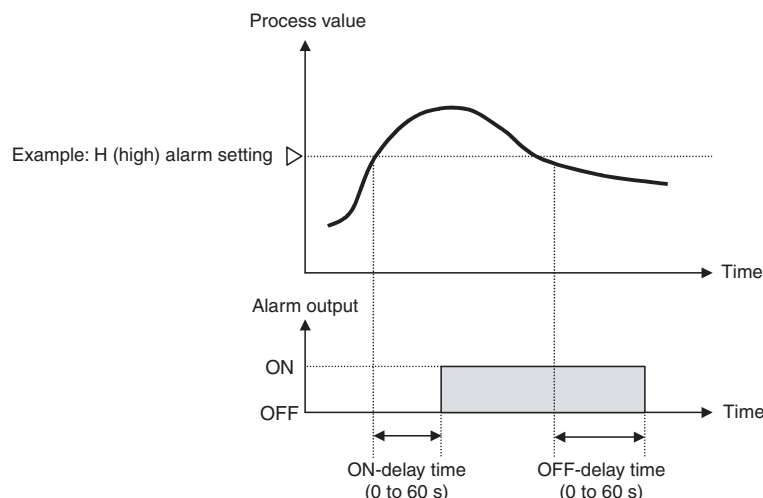

Mean Value Processing

The moving average of a specified number (from 1 to 16) of past process values (or instantaneous values) can be calculated and stored as the process value. An input noise filter can be installed if erroneous process values are obtained due to noise, or if the system has sudden voltage or current fluctuations.

| | | |
|------------------|--|----------------------------------|
| Applicable Units | Isolated-type Thermocouple Input Units | CS1W-PTS01-V1/11, CJ1W-PTS15 |
| | Isolated-type Resistance Thermometer Input Units | CS1W-PTS02/03/12, CJ1W-PTS16 |
| | Isolated-type 2-Wire Transmitter Input Unit | CS1W-PTW01 |
| | Isolated-type Direct Current Input Units | CS1W-PDC01/11, PTR02, CJ1W-PDC15 |
| | Power Transducer Input Unit | CS1W-PTR01 |
| | Isolated-type Pulse Input Unit | CS1W-PPS01 |
| | Isolated-type Universal Input Unit | CJ1W-PH41U |

Note For the CS1W-PTR01 and CS1W-PTR02, four process values are always averaged. For the CS1W-PTS11, CS1W-PTS12, CS1W-PDC11, CJ1W-PTS15, CJ1W-PTS16, CJ1W-PDC15 and CJ1W-PH41U the number of values to be averaged can be set to between 1 and 128.

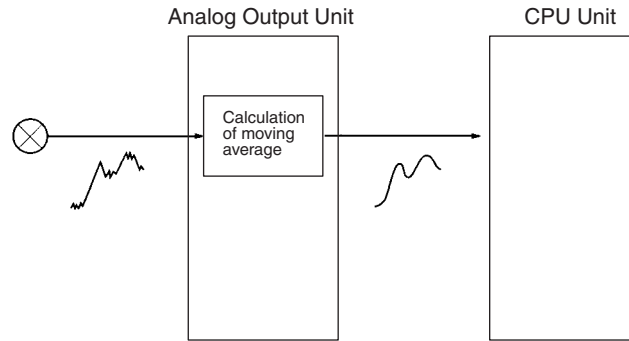

Input Disconnection Detection

Sensor disconnections can be detected for thermocouple input and resistance thermometer input. Either the high (115%) or low (-15%) direction can be specified for when a disconnection is detected.

| | | |
|------------------|--|------------------------------|
| Applicable Units | Isolated-type Thermocouple Input Units | CS1W-PTS01-V1/11, CJ1W-PTS15 |
| | Isolated-type Resistance Thermometer Input Units | CS1W-PTS02/03/12, CJ1W-PTS16 |
| | Isolated-type Universal Input Unit | CJ1W-PH41U (See note.) |

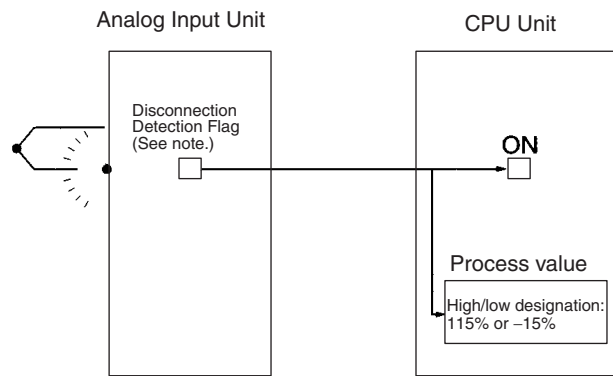

Note For the CJ1W-PH41U, this is the Input Error Flag.

Input Error Detection

An errors resulting from exceeding the high or low limits can be detected.

| | | |
|------------------|--|------------------------------|
| Applicable Units | Isolated-type Thermocouple Input Units | CS1W-PTS51/55, CJ1W-PTS51 |
| | Isolated-type Resistance Thermometer Input Units | CS1W-PTS52/56, CJ1W-PTS52 |
| | Isolated-type 2-Wire Transmitter Input Unit | CS1W-PTW01-V1 |
| | Isolated-type Direct Current Input Units | CS1W-PDC01/11/55, CJ1W-PDC15 |
| | Isolated-type Universal Input Unit | CJ1W-PH41U |

Note An input error will be detected for the CS1W-PTS5□ or CJ1W-PTS5□ if the input exceeds 20 digits for the high or low limits of the sensor range. For the CS1W-PDC55, an input error will be detected if the input exceeds -5% or +105% for the internal range full span.

Cold Junction Sensor Errors Detection

If a Thermocouple Input Unit or Universal Input Unit built-in cold junction sensor is disconnected, if short-circuiting occurs, or if an error occurs at the cold junction sensor, the Cold Junction Error Flag will turn ON and the temperature process value with no cold junction compensation will be stored in the CIO Area.

| | | |
|------------------|--|---------------------------------------|
| Applicable Units | Isolated-type Thermocouple Input Units | CS1W-PTS01-V1/11/51/55, CJ1W-PTS51/15 |
| | Isolated-type Universal Input Unit | CJ1W-PH41U |

- Note**
1. If one of the two cold junction sensors is disconnected as described above, cold junction compensation will be stopped for all inputs.
 2. There is only one cold junction sensor for the CS1W-PTS51 and the CJ1W-PH41U. There are two cold junction sensors for the CJ1W-PTS15.

Square Root

For 2-wire transmitter input and analog input, this function takes as the process value the square root of the analog input value. It is used for operations such as calculating momentary flow based on the differential pressure input from a differential pressure transmitter.

With linear characteristics at an output of approximately 7% or less, an on-site differential pressure transmitter's zero-point adjustment can be performed with this function enabled.

- Note** The square root function is enabled only when the maximum scaling value is greater than the minimum scaling value. Square root extraction will not be possible if the minimum scaling value is greater.

| | | |
|------------------|---|------------------------------|
| Applicable Units | Isolated-type Direct Current Input Units | CS1W-PDC01/11/55, CJ1W-PDC15 |
| | Isolated-type 2-Wire Transmitter Input Unit | CS1W-PTW01 |
| | Isolated-type Universal Input Units | CJ1W-PH41U (See note 1.) |

- Note**
1. Enabled for DC input only.
 2. The square root function can be used with the CS1W-PDC55 only when using the 1 to 5 V or 4 to 40 mA range.

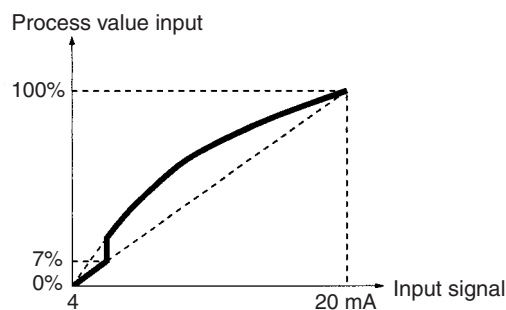

Inrush Input Limit

The inrush input limit function temporarily limits the process value input to a given set value when it increases from a low value (2%). This function is used for preventing a process value alarm from being generated by the inrush current, e.g., when the motor is started.

| | | |
|------------------|-----------------------------|------------|
| Applicable Units | Analog Input Unit (100 mA) | CS1W-PTR02 |
| | Power Transducer Input Unit | CS1W-PTR01 |

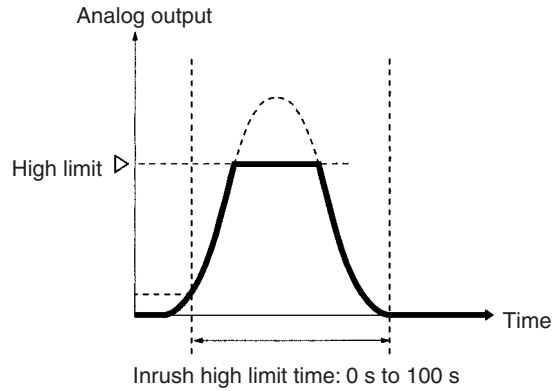

Zero/Span Adjustment

The zero point and span point can be adjusted for a process value (or instantaneous value). The zero adjustment offsets the line plotting values before and after adjustment parallel to the original line. The span adjustment changes the slope of the line (i.e., the gain) around the minimum value in the range (i.e., the minimum value is not changed). The zero adjustment value and the span adjustment gain are set in the DM Area words allocated in the CPU Unit. These settings are refreshed during operation, so the values can be adjusted under normal operating conditions.

Also, with the CS1W-PTS11/PTS12, CS1W-PDC11, and CJ1W-PTS15/PTS16/PDC15/PH41U, the zero point and span point can be adjusted for a specified point (position) other than 0% or 100%. The zero adjustment value and span adjustment gain for specified points are set in the Expansion Setting Area allocated to the Unit.

Refer to *Appendix B Zero/Span Adjustment Example* for details.

Zero/Span Adjustment Only

| | | |
|------------------|--|------------------------------------|
| Applicable Units | Isolated-type Thermocouple Input Units | CS1W-PTS01-V1/11/51/55, CJ1W-PTS51 |
| | Isolated-type Resistance Thermometer Input Units | CS1W-PTS02/03/12/52/56, CJ1W-PTS52 |
| | Isolated-type 2-Wire Transmitter Input Unit | CS1W-PTW01 |
| | Isolated-type Direct Current Input Units | CS1W-PDC01/11/55, PTR02 |
| | Power Transducer Input Unit | CS1W-PTR01 |
| | Isolated-type Pulse Input Unit | CS1W-PPS01 |
| | Isolated-type Analog Output Units | CS1W-PMV01/PMV02 |

Zero/Span Adjustment and Zero/Span Adjustment for Specified Points

| | | |
|------------------|---|------------------------|
| Applicable Units | Isolated-type Thermocouple Input Unit | CS1W-PTS11, CJ1W-PTS15 |
| | Isolated-type Resistance Thermometer Input Unit | CS1W-PTS12, CJ1W-PTS16 |
| | Isolated-type Analog Input Unit | CS1W-PDC11, CJ1W-PDC15 |
| | Isolated-type Universal Input Unit | CJ1W-PH41U |

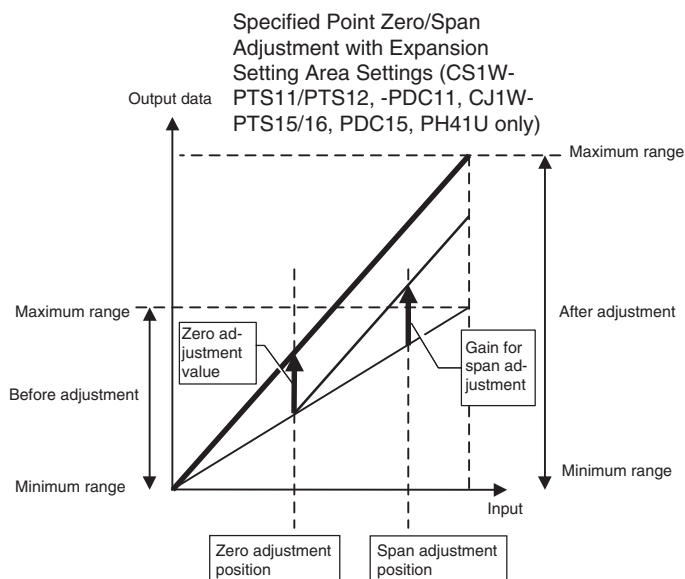
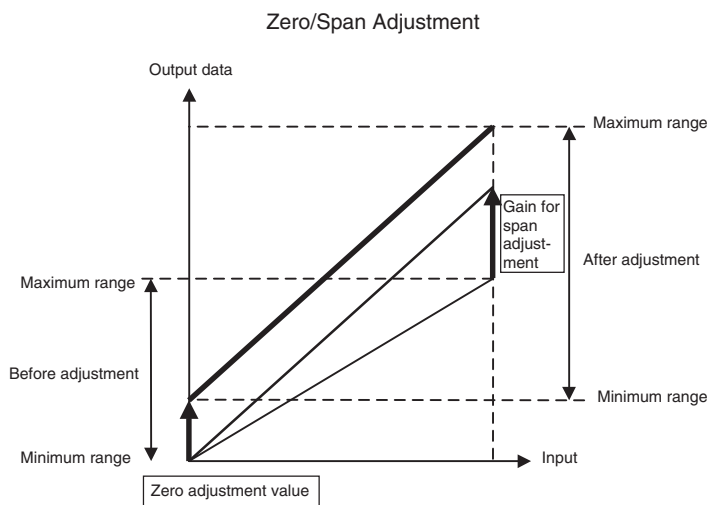
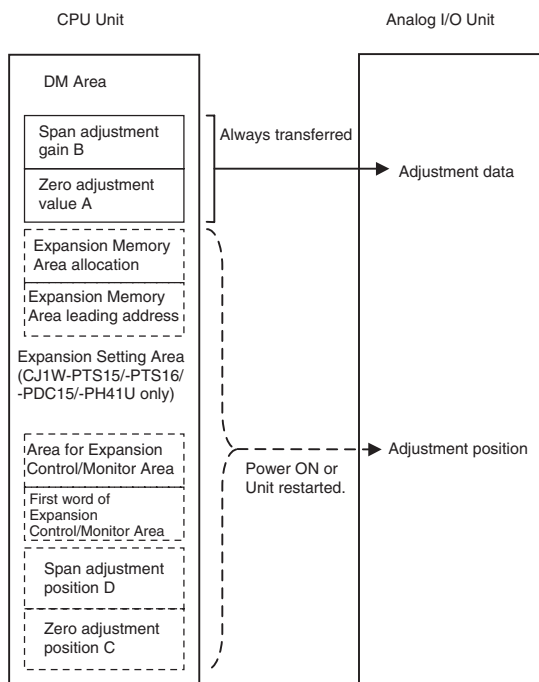

Stepdown

This function reduces the number of pulses by 1/10, 1/100, or 1/1,000. It only operates for an accumulating counter (and not for instantaneous values). Make this setting to prevent accumulating counter overflow. If the number of pulses is 3,000, for example, setting the stepdown rate to 1/100 will reduce the number to 30, and the totalizing will then be based on that value.

| | | |
|------------------|--------------------------------|------------|
| Applicable Units | Isolated-type Pulse Input Unit | CS1W-PPS01 |
|------------------|--------------------------------|------------|

Pulse Input Instantaneous Value Conversion

This function counts the number of pulses per time unit and converts the number to an instantaneous value (pulses/time unit). Any of the following time

units can be selected: 1 s, 3 s, 10 s, 30 s, or 60 s. (These match the cycles for conversion to instantaneous values.)

When the number of pulses per time unit (i.e., pulse rate) is low, lengthen the time unit. The instantaneous value stored, however, can only be refreshed at intervals of this time unit.

If there is fluctuation in the instantaneous values, the moving average function can be used to even the values out through averaging. Calculate the moving average for the specified number of values, and then convert it to the number of pulses per time unit. To determine the number of values for averaging, observe the operating status.

| | | |
|------------------|--------------------------------|------------|
| Applicable Units | Isolated-type Pulse Input Unit | CS1W-PPS01 |
|------------------|--------------------------------|------------|

Pulse Accumulation

Pulse Input Units can accumulate pulses within a range of 0 to 9,999 (0000 to 270F hex). With each accumulation conversion period, the number of input pulses after the stepdown is added. If the accumulated value exceeds 9,999, pulses are accumulated again from 0000. When the PLC is turned ON or the Unit is restarted, the accumulated value is reset to 0 and the Accumulation Reset Bit turns ON for 10 seconds.

| | | |
|------------------|--------------------------------|------------|
| Applicable Units | Isolated-type Pulse Input Unit | CS1W-PPS01 |
|------------------|--------------------------------|------------|

Answer Input

During analog output, the actual analog output (current or voltage) signal can be checked by being read again from the analog output terminals. This function is used for checking for actual output load discrepancies due to external load resistance, or for checking actual analog signal values when an output rate-of-change limit is used.

| | | |
|------------------|----------------------------------|------------|
| Applicable Units | Isolated-type Analog Output Unit | CS1W-PMV01 |
|------------------|----------------------------------|------------|

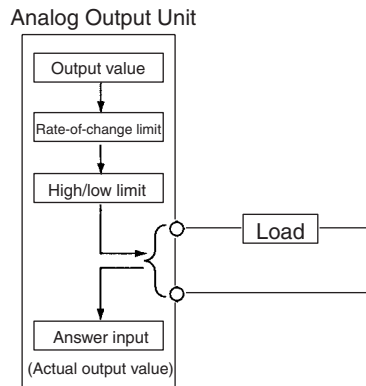

Output Rate-of-change Limit

With this function, the analog output value's rate of change can be limited separately for the positive and negative directions.

| | | |
|------------------|-----------------------------------|------------------|
| Applicable Units | Isolated-type Analog Output Units | CS1W-PMV01/PMV02 |
|------------------|-----------------------------------|------------------|

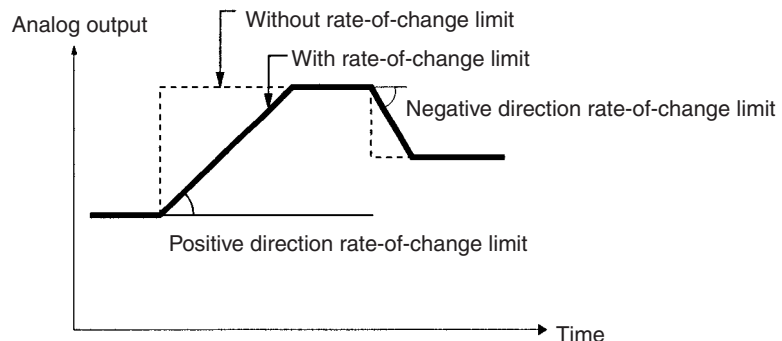

Output Disconnection Detection

If a current loop is disconnected during analog output, this function will detect it.

| | | |
|------------------|----------------------------------|------------|
| Applicable Units | Isolated-type Analog Output Unit | CS1W-PMV01 |
|------------------|----------------------------------|------------|

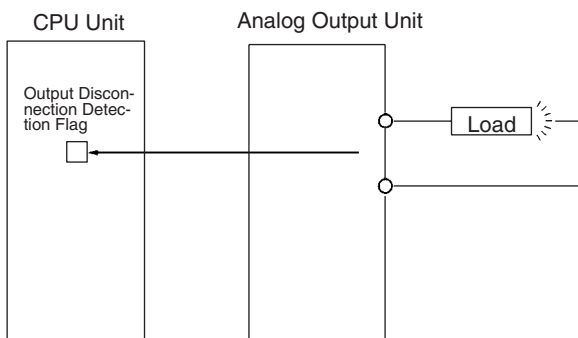

Output Hold When CPU Unit Error Occurs

When a fatal error (including user-defined FALS execution), or a CPU error in the CPU Unit occurs, or all outputs are turned OFF with the Output OFF Bit, this function can hold either a preset value or the analog output value prior to the error. When the CPU Unit is restored to normal operation, the output value in the CIO Area is output.

| | | |
|------------------|-----------------------------------|------------------|
| Applicable Units | Isolated-type Analog Output Units | CS1W-PMV01/PMV02 |
|------------------|-----------------------------------|------------------|

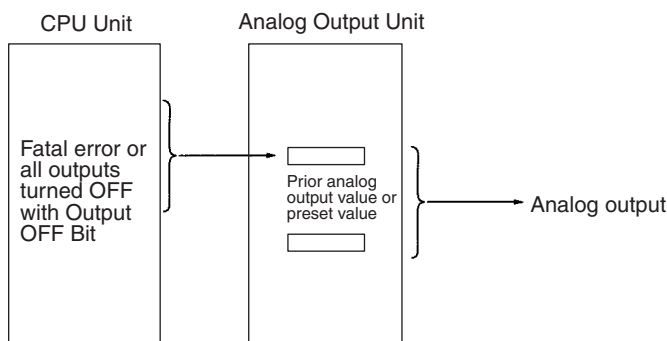

Adjustment Period Control

When zero/span adjustment is executed, the date is internally recorded at the Unit. When the preset zero/span adjustment period and the notice of days remaining have elapsed, this function turns ON a warning flag to give notice that it is time for readjustment.

| | | |
|------------------|---|------------------------|
| Applicable Units | Isolated-type Thermocouple Input Unit | CS1W-PTS11, CJ1W-PTS15 |
| | Isolated-type Resistance Thermometer Input Unit | CS1W-PTS12, CJ1W-PTS16 |
| | Isolated-type Analog Input Unit | CS1W-PDC11, CJ1W-PDC15 |
| | Isolated-type Universal Input Unit | CJ1W-PH41U |

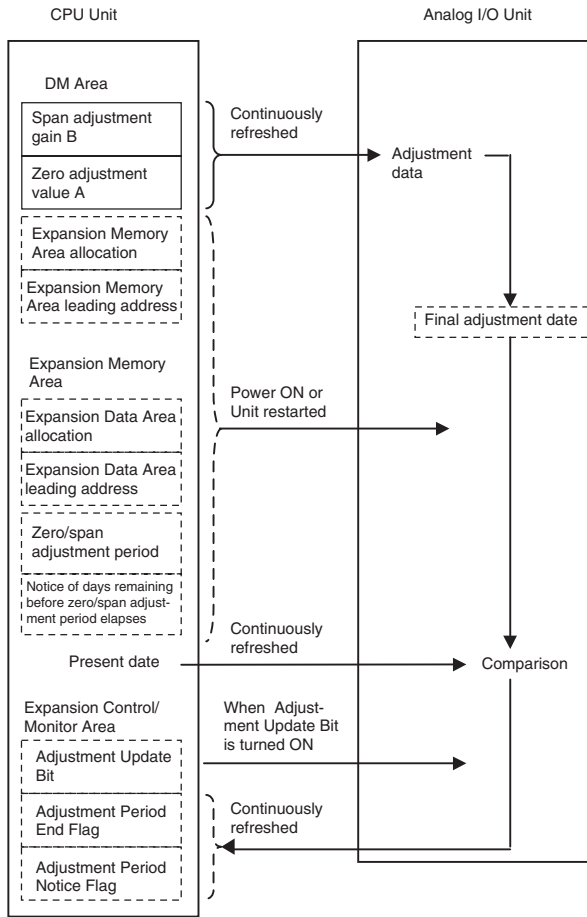

Example:
 Zero/span adjustment period = 180 days
 Notice of days remaining before zero/span adjustment period elapses = 30 days
 July 3, 2002: Zero/span adjustment executed.
 ↓
 November 30, 2002: Adjustment Period Notice Flag
 December 30, 2002: Adjustment Period End Flag

Peak and Bottom Detection

This function detects the maximum (peak) and minimum (bottom) analog input values, from when the Hold Start Bit (output) allocated in the Expansion Control/Monitor Area turns ON until it turns OFF. The peak and bottom values in the Expansion Control/Monitor Area are constantly refreshed, and they are cleared to zero while the Hold Value Reset Bit is ON.

| | | |
|------------------|---|------------------------|
| Applicable Units | Isolated-type Thermocouple Input Unit | CS1W-PTS11, CJ1W-PTS15 |
| | Isolated-type Resistance Thermometer Input Unit | CS1W-PTS12, CJ1W-PTS16 |
| | Isolated-type Analog Input Unit | CS1W-PDC11, CJ1W-PDC15 |
| | Isolated-type Universal Input Unit | CJ1W-PH41U |

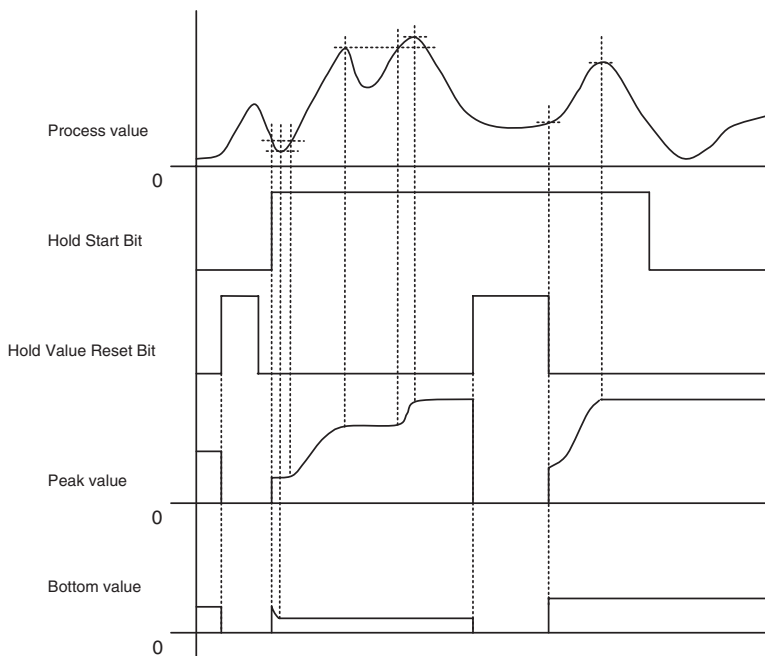

Note The top and valley detection function and the peak and bottom detection function cannot be used simultaneously.

Top and Valley Detection

This function detects the top and valley values of the process value from when the Hold Start Bit (output) in the Expansion Control/Monitor Area turns ON until it turns OFF. A detection hysteresis can be set so that minute changes are not detected. The top and valley values in the Expansion Control/Monitor Area are constantly refreshed, and they are cleared to zero while the Hold Value Reset Bit is ON.

| | | |
|------------------|---|------------------------|
| Applicable Units | Isolated-type Thermocouple Input Unit | CS1W-PTS11, CJ1W-PTS15 |
| | Isolated-type Resistance Thermometer Input Unit | CS1W-PTS12, CJ1W-PTS16 |
| | Isolated-type Analog Input Unit | CS1W-PDC11, CJ1W-PDC15 |
| | Isolated-type Universal Input Unit | CJ1W-PH41U |

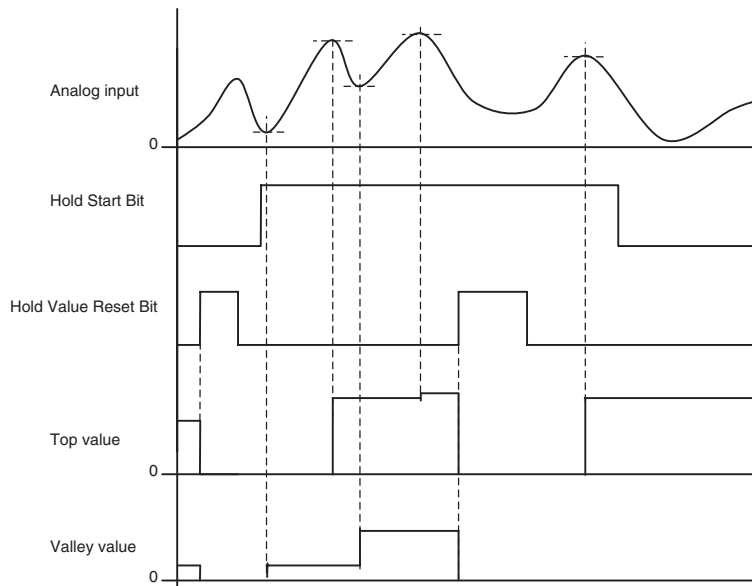

Note Either peak and bottom values or top and valley values can be selected for detection. This selection is made by using the Hold Function Selection Flag in the Expansion Control/Monitor Area to select either the top and valley detection function or the peak and bottom detection function. These two functions cannot be used simultaneously.

Integral Value Calculation (CS1W-PDC11 and CJ1W-PDC15/PH41U Only)

This function calculates the integral of the process value over time. The unit can be selected as either “hour” or “minute” by a setting in the Expansion Setting Area.

The integral value can be output to the Expansion Monitor/Control Area by turning ON the Integral Value Calculation Start Bit in the Expansion Monitor/Control Area. It can also be cleared to zero by turning ON the Integral Value Reset Bit in the Expansion Monitor/Control Area.

In addition, with the CJ1W-PH41U, the integral value can be calculated using an integral value coefficient to prevent integral value overflow.

| | | |
|------------------|------------------------------------|------------------------|
| Applicable Units | Isolated-type Analog Input Unit | CS1W-PDC11, CJ1W-PDC15 |
| | Isolated-type Universal Input Unit | CJ1W-PH41U |

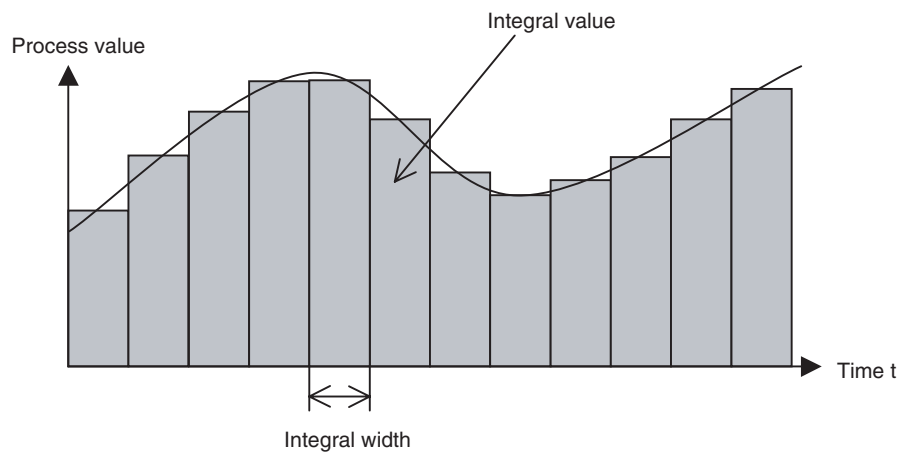

Cold Junction Compensation Method

This function specifies whether cold junction compensation for thermocouple inputs is to be performed in the Analog I/O Unit or externally. The external method is enabled when the temperature difference is measured using two

thermocouples or when an external cold-junction compensator is used for greater precision.

| | | |
|------------------|-------------------------------------|------------|
| Applicable Units | Isolated-type Universal Input Units | CJ1W-PH41U |
|------------------|-------------------------------------|------------|

Temperature Resistance Thermometer Compensation

This function performs compensation for resistance thermometer inputs according to the reference resistance for a connected resistance thermometer. Set the Temperature Resistance Thermometer Compensation Enable setting in the Expansion Setting Area to Enable and then set the Reference Resistance (i.e., the resistance at 23°C) in the Expansion Setting Area.

| | | |
|------------------|-------------------------------------|------------|
| Applicable Units | Isolated-type Universal Input Units | CJ1W-PH41U |
|------------------|-------------------------------------|------------|

1-3 System Configuration

CS Series

These Analog I/O Units belong to the CS-series Special I/O Unit group.

- They can be mounted to CS-series CPU Racks or Expansion I/O Racks.
- They cannot be mounted to C200H CPU Racks, Expansion I/O Racks, or SYSMAC BUS Remote I/O Slave Racks.

The number of Units that can be mounted to one Rack (either a CPU Rack or Expansion I/O Rack) depends upon the maximum current supplied by the Power Supply Unit and the current consumption by the other Units.

There are no restrictions on Rack position.

Note I/O addresses for Special I/O Units are allocated according to the unit number set on the switches on the front panel, and not according to the slot position in which they are mounted.

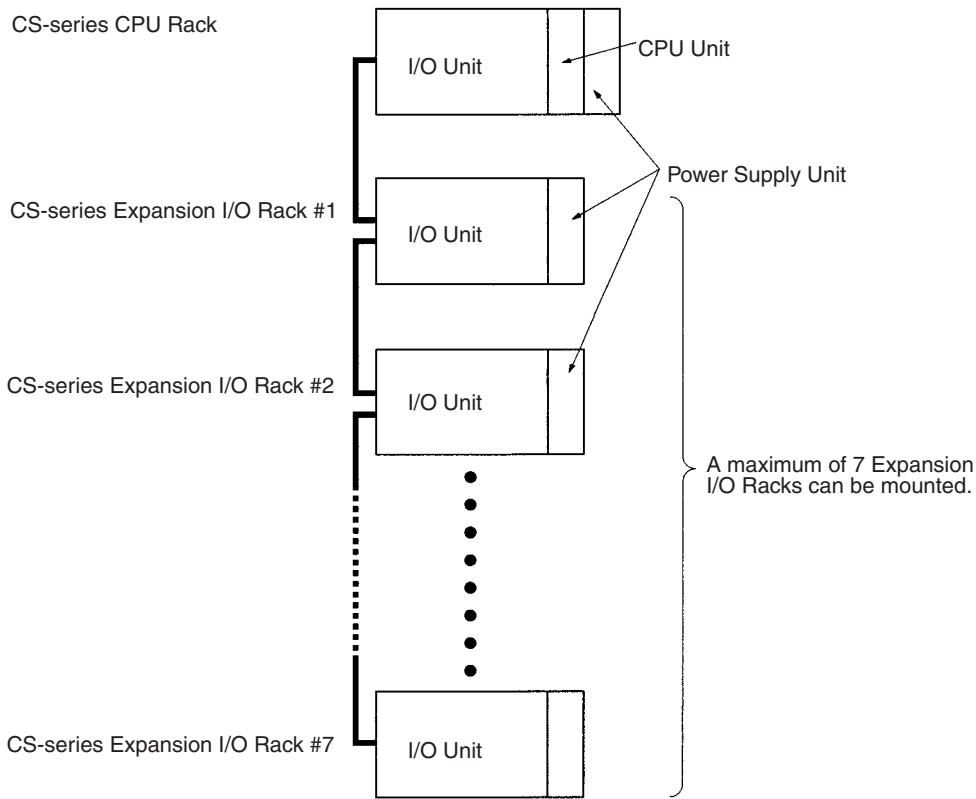

CJ Series

These Analog I/O Units belong to the CJ-series Special I/O Unit group.

- They can be mounted to CJ-series CPU Racks or Expansion I/O Racks.

The number of Units that can be mounted to one Rack (either a CPU Rack or Expansion I/O Rack) depends upon the maximum current supplied by the Power Supply Unit and the current consumption by the other Units.

There are no restrictions on Rack position.

Note I/O addresses for Special I/O Units are allocated according to the unit number set on the switches on the front panel, and not according to the slot position in which they are mounted.

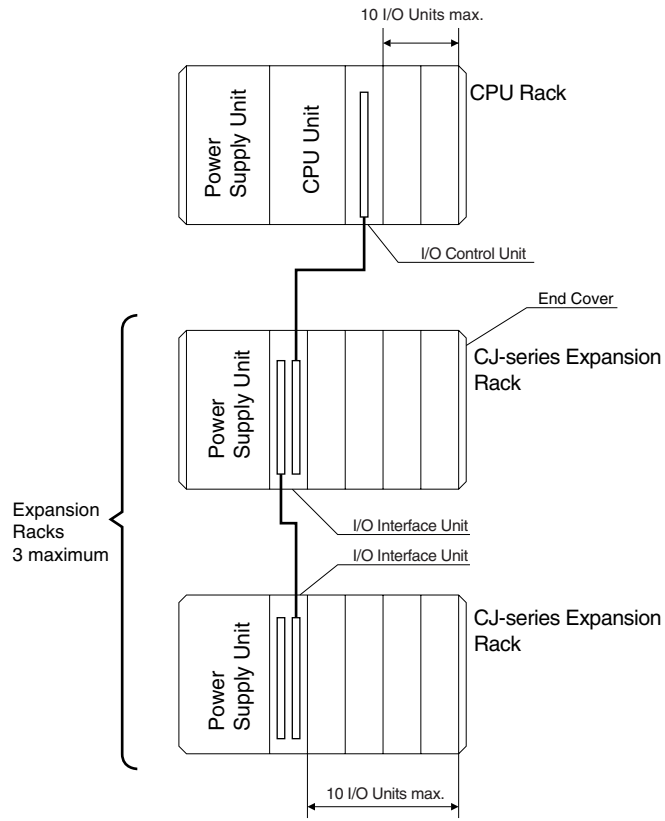

1-4 Specifications and Installation

1-4-1 Specifications

CS Series

The specifications shown in the following table apply to all the CS-series Analog I/O Units. For specifications and installation procedures specific to each Unit, refer to the explanations in *SECTION 2 Individual Unit Descriptions for CS Series*.

| Item | Specification |
|-------------------------------|--|
| Unit classification | CS-series Special I/O Unit |
| Structure | Backplane-mounted, single slot size |
| Dimensions | 35 × 130 × 126 mm (W × H × D) |
| Weight | 450 g max. |
| External connection terminals | <ul style="list-style-type: none"> • CS1W-PTS55/-PTS56/-PDC55 24-point removable terminal block (with lever) (M3 screws, Tightening torque: 0.5 N·m) • Other Units 21-point removable terminal block (M3 screws, Tightening torque: 0.5 N·m) |
| Unit number switch setting | 00 to 95 |
| Self-diagnosis function | Results of self-diagnosis shown on indicators. |
| Mountable Racks | CPU Rack or CS-series Expansion Rack |
| Maximum number of Units | 80 Units (10 Units × 8 Racks) Confirm that the total current consumption of all the Units (including the CPU Unit) mounted to a single CPU Rack or Expansion Rack does not exceed the maximum power supply capacity of the Power Supply Unit. |
| Ambient operating temperature | 0 to 55°C |
| Ambient operating humidity | 10% to 90% (with no condensation) |

Current consumption

| Name | Model | Current consumption (power) | |
|--|---------------|-----------------------------|-----------------|
| | | 5 V | 26 V |
| Isolated-type Thermocouple Input Unit | CS1W-PTS01-V1 | 0.15 A (0.75 W) | 0.15 A (3.9 W) |
| | CS1W-PTS11 | 0.16 A (0.60 W) | 0.08 A (2.08 W) |
| | CS1W-PTS51 | 0.25 A (1.25 W) | Not used. |
| | CS1W-PTS55 | 0.18 A (0.90 W) | 0.06 A (1.56 W) |
| Isolated-type Resistance Thermometer Input Unit (Pt100, JPt100) | CS1W-PTS02 | 0.15 A (0.75 W) | 0.15 A (3.9 W) |
| Isolated-type Resistance Thermometer Input Unit (Ni508.4) | CS1W-PTS03 | 0.15 A (0.75 W) | 0.15 A (3.9 W) |
| Isolated-type Resistance Thermometer Input Unit (Pt100, JPt100, Pt50, Ni508.4) | CS1W-PTS12 | 0.12 A (0.60 W) | 0.07 A (1.82 W) |
| Isolated-type Resistance Thermometer Input Unit (Pt100, JPt100) | CS1W-PTS52 | 0.25 A (1.25 W) | Not used. |
| | CS1W-PTS56 | 0.18 A (0.90 W) | 0.06 A (1.56 W) |
| Isolated-type 2-Wire Transmitter Input Unit | CS1W-PTW01 | 0.15 A (0.75 W) | 0.16 A (4.2 W) |

| Name | Model | Current consumption (power) | |
|---|------------|-----------------------------|-----------------|
| | | 5 V | 26 V |
| Isolated-type Direct Current Input Unit | CS1W-PDC01 | 0.15 A (0.75 W) | 0.16 A (4.2 W) |
| | CS1W-PDC11 | 0.12 A (0.60 W) | 0.12 A (3.12 W) |
| | CS1W-PDC55 | 0.18 A (0.90 W) | 0.06 A (1.56 W) |
| Power Transducer Input Unit | CS1W-PTR01 | 0.15 A (0.75 W) | 0.08 A (2.1 W) |
| Analog Input Unit (100 mV) | CS1W-PTR02 | 0.15 A (0.75 W) | 0.08 A (2.1 W) |
| Isolated-type Pulse Input Unit | CS1W-PPS01 | 0.20 A (1.00 W) | 0.16 A (4.2 W) |
| Isolated-type Analog Output Unit | CS1W-PMV01 | 0.15 A (0.75 W) | 0.16 A (4.2 W) |
| | CS1W-PMV02 | 0.12 A (0.60 W) | 0.12 A (3.2 W) |

(Reference) Maximum current and total power supplied

| Power Supply Unit | Maximum current supplied (power) | | | Maximum total power |
|-------------------|----------------------------------|-----------------|----------------|---------------------|
| | 5 V | 26 V | 24 V | |
| C200HW-PA204 | 4.6 A (23 W) | 0.6 A (15.6 W) | None | 30 W |
| C200HW-PA204C | 4.6 A (23 W) | 0.6 A (15.6 W) | None | 30 W |
| C200HW-PA204S | 4.6 A (23 W) | 0.6 A (15.6 W) | 0.8 A (19.2 W) | 30 W |
| C200HW-PA204R | 4.6 A (23 W) | 0.6 A (15.6 W) | None | 30 W |
| C200HW-PD024 | 4.6 A (23 W) | 0.6 A (15.6 W) | None | 30 W |
| C200HW-PA209R | 9 A (45 W) | 1.3 A (33.8 W) | None | 45 W |
| C200HW-PD025 | 5.3 A | 1.3 A | None | 40 W |
| CS1D-PA207R | 7 A (35 W) | 1.3 A (33.8 W) | None | 35 W |
| CS1D-PD024 | 4.3 A (21.5 W) | 0.56 A (14.6 W) | None | 28 W |
| CS1D-PD025 | 5.3 A | 1.3 A | None | 40 W |

CJ Series

The specifications shown in the following table apply to all the CJ-series Analog I/O Units. For specifications and installation procedures specific to each Unit, refer to the explanations in *SECTION 3 Individual Unit Descriptions for CJ Series*.

| Item | Specification |
|-------------------------------|---|
| Unit classification | CJ-series Special I/O Unit |
| Dimensions | 31 × 90 × 65 mm (W × H × D) |
| Weight | 150 g max. |
| Maximum number of Units | 40 Units (10 Units × 4 Racks) Confirm that the total current consumption of all the Units (including the CPU Unit) mounted to a single CPU Rack or Expansion Rack does not exceed the maximum power supplied by the Power Supply Unit. |
| Ambient operating temperature | 0 to 55°C |
| Ambient operating humidity | 10% to 90% (with no condensation) |

Current consumption

| Name | Model | Current consumption (power) | |
|--|------------|-----------------------------|---------------|
| | | 5 V | 24-V external |
| Isolated-type Thermo-couple Input Unit | CJ1W-PTS51 | 0.25 A (1.25 W) | Not used. |
| | CJ1W-PTS15 | 0.18 A (0.9 W) | 0.06 A |

| Name | Model | Current consumption (power) | |
|---|------------|-----------------------------|---------------|
| | | 5 V | 24-V external |
| Isolated-type Resistance Thermometer Input Unit (Pt100, JPt100) | CJ1W-PTS52 | 0.25 A (1.25 W) | Not used. |
| | CJ1W-PTS16 | 0.18 A (0.9 W) | 0.07 A |
| Isolated-type Direct Current Input Unit | CJ1W-PDC15 | 0.18 A (0.9 W) | 0.09 A |
| Isolated-type Universal Input Unit | CJ1W-PH41U | 0.30 A (1.5 W) | Not used. |

(Reference) Maximum current and total power supplied

| Power Supply Unit | Maximum current supplied (power) | | Maximum total power |
|--------------------|----------------------------------|---------------------------|---------------------|
| | 5 V | 24-V relay driver current | |
| CJ1W-PA205R/PA205C | 5.0 A (25 W) | 0.8 A | 25 W |
| CJ1W-PA202 | 2.8 A (14 W) | 0.4 A | 14 W |
| CJ1W-PD025 | 5.0 A (25 W) | 0.8 A | 25 W |
| CJ1W-PD022 | 2.0 A (10 W) | 0.4 A | 19.6 W |

1-4-2 Nomenclature and Functions

CS Series

CS1W-P□□0□/1□/51/52

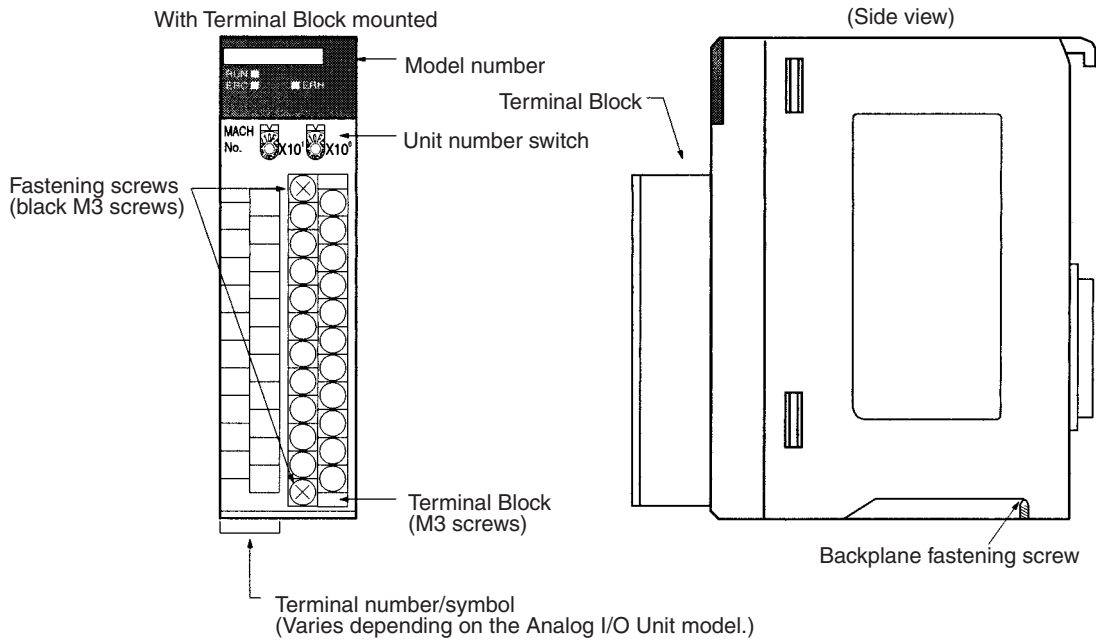

- Note**
1. The Terminal Block is detachable, with connectors. It can be removed by loosening the two black screws (on the top and bottom).
 2. Always confirm that the black Terminal Block mounting screws are tightened to a torque of 0.5 N·m.

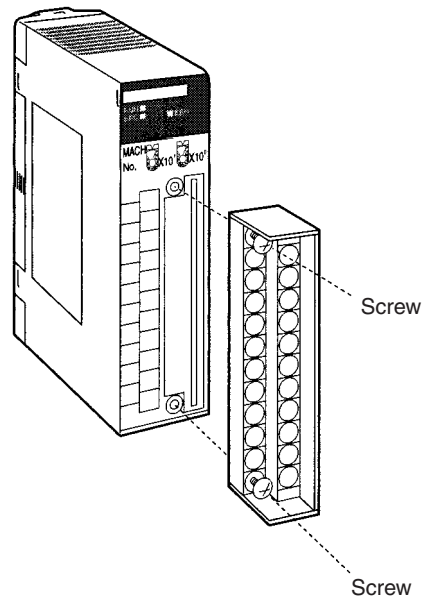

CS1W-PTS55/56, PDC55

With Terminal Block mounted

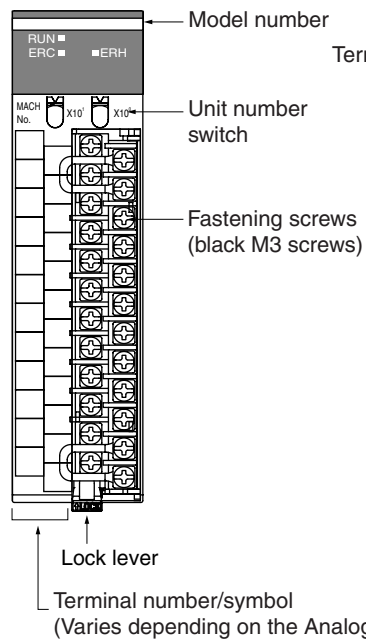

(Side view)

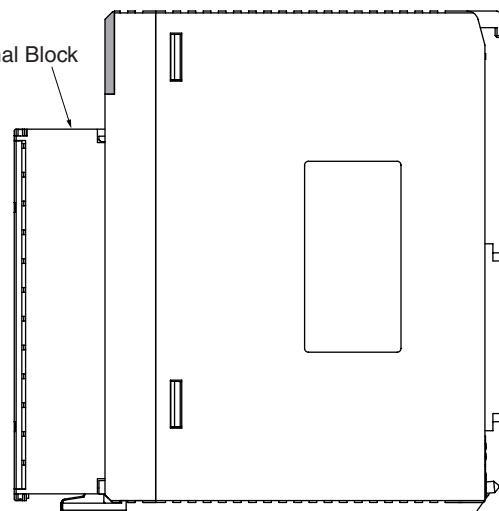

Note The Terminal Block is detachable, with Lock lever. It can be removed by unlocking the lock lever.

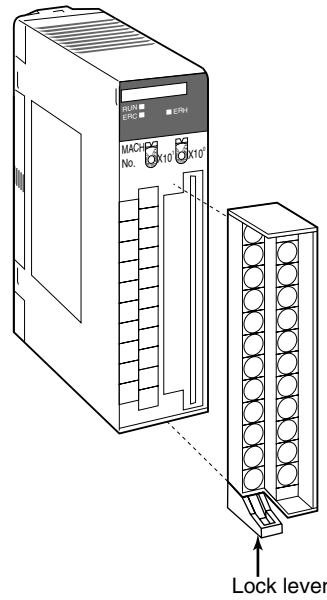

Front Panel LED Indicators

■ CS1W-P□□0□/1□

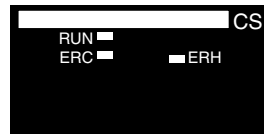

| LED | Meaning | Indicator | Operating status |
|----------------|------------------------|-----------|---|
| RUN (green) | Operating | Lit | Operating normally. |
| | | Not lit | Unit has stopped exchanging data with the CPU Unit. |
| ERC (red) | Error detected by Unit | Lit | Data setting is out of range in the DM Area. |
| | | Not lit | Operating normally. |
| ERH (red) | Error in the CPU Unit | Lit | Error has occurred during data exchange with the CPU Unit, or Analog I/O Unit's unit number is set incorrectly, or there is a mounting error. |
| | | Not lit | Operating normally. |

■ CS1W-PTS55/56, PDC55



| LED | Meaning | Indicator | Operating status |
|----------------|------------------------|-----------|---|
| RUN (green) | Operating | Lit | Operating normally. |
| | | Not lit | Unit has stopped exchanging data with the CPU Unit. |
| ERC (red) | Error detected by Unit | Lit | Sensor error has occurred or data setting is out of range in the DM Area. |
| | | Not lit | Operating normally. |

| LED | Meaning | Indicator | Operating status |
|--------------|-----------------------|-----------|---|
| ERH (red) | Error in the CPU Unit | Lit | Error has occurred during data exchange with the CPU Unit, or Analog I/O Unit's unit number is set incorrectly, or there is a mounting error. |
| | | Not lit | Operating normally. |

■ **CS1W-PTS51/52**

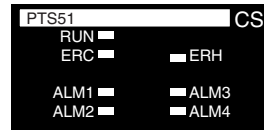

| LED | Meaning | Indicator | Operating status |
|--------------------------|------------------------|-----------|---|
| RUN (green) | Operating | Lit | Operating normally. |
| | | Not lit | Unit has stopped exchanging data with the CPU Unit. |
| ERC (red) | Error detected by Unit | Lit | Sensor error has occurred or data setting is out of range in the DM Area. |
| | | Not lit | Operating normally. |
| ERH (red) | Error in the CPU Unit | Lit | Error has occurred during data exchange with the CPU Unit, or Analog I/O Unit's unit number is set incorrectly, or there is a mounting error. |
| | | Not lit | Operating normally. |
| ALM1 to ALM4 (yellow) | External alarm outputs | Lit | External alarm output ON |
| | | Not lit | External alarm output OFF |

Unit Number Switches

The CPU Unit and Analog Input Unit exchange data via words allocated to the Analog Input Unit as a Special I/O Unit. Words are allocated to Special I/O Units in both the CIO Area and the DM Area.

The words that each Analog I/O Unit uses are determined by the setting of the unit number switches on the front panel of the Unit.

Unit number switches

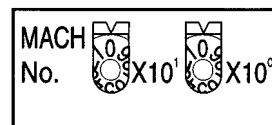

| Unit No. | CIO Area addresses | DM Area addresses |
|----------|----------------------|-------------------|
| 0 | CIO 2000 to CIO 2009 | D20000 to D20099 |
| 1 | CIO 2010 to CIO 2019 | D20100 to D20199 |
| 2 | CIO 2020 to CIO 2029 | D20200 to D20299 |
| 3 | CIO 2030 to CIO 2039 | D20300 to D20399 |
| 4 | CIO 2040 to CIO 2049 | D20400 to D20499 |
| 5 | CIO 2050 to CIO 2059 | D20500 to D20599 |
| 6 | CIO 2060 to CIO 2069 | D20600 to D20699 |
| 7 | CIO 2070 to CIO 2079 | D20700 to D20799 |
| 8 | CIO 2080 to CIO 2089 | D20800 to D20899 |
| 9 | CIO 2090 to CIO 2099 | D20900 to D20999 |
| 10 | CIO 2100 to CIO 2109 | D21000 to D21099 |
| to | to | to |

| Unit No. | CIO Area addresses | DM Area addresses |
|----------|--|---|
| n | CIO 2000 + n × 10 to CIO 2000 + n × 10 + 9 | D20000 + n × 100 to D20000 + n × 100 + 99 |
| to | to | to |
| 95 | CIO 2950 to CIO 2959 | D29500 to D29599 |

Note If two or more Special I/O Units are assigned the same unit number, a “UNIT No. DPL ERR” error (in the Programming Console) will occur (A401.13 will turn ON) and the PLC will not operate.

CJ Series

Front Panel LED Indicators

■ **CJ1W-PTS5**

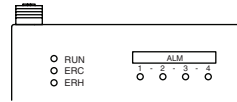

| LED | Meaning | Indicator | Operating status |
|-----------------------|------------------------|-----------|---|
| RUN (green) | Operating | Lit | Operating normally. |
| | | Not lit | Unit has stopped exchanging data with the CPU Unit. |
| ERC (red) | Error detected by Unit | Lit | Sensor error has occurred or data setting is out of range in the DM Area. |
| | | Not lit | Operating normally. |
| ERH (red) | Error in the CPU Unit | Lit | Error has occurred during data exchange with the CPU Unit, or Analog I/O Unit's unit number is set incorrectly, or there is a mounting error. |
| | | Not lit | Operating normally. |
| ALM1 to ALM4 (yellow) | External alarm outputs | Lit | External alarm output ON. |
| | | Not lit | External alarm output OFF. |

■ **CJ1W-PTS15/PTS16/PDC15**

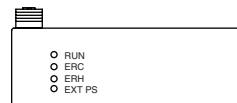

| LED | Meaning | Indicator | Operating status |
|-----------------|------------------------|-----------|---|
| RUN (green) | Operating | Lit | Operating normally. |
| | | Not lit | Unit has stopped exchanging data with the CPU Unit. |
| ERC (red) | Error detected by Unit | Lit | Data setting is out of range in the DM Area. |
| | | Not lit | Operating normally. |
| ERH (red) | Error in the CPU Unit | Lit | Error has occurred during data exchange with the CPU Unit, or Analog I/O Unit's unit number is set incorrectly, or there is a mounting error. |
| | | Not lit | Operating normally. |
| EXT PS (yellow) | External power supply | Lit | External 24-VDC power supply |
| | | Not lit | No external power supply |

■ **CJ1W-PH41U**

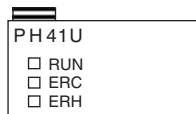

| LED | Meaning | Indicator | Operating status |
|----------------|------------------------|-----------|---|
| RUN (green) | Operating | Lit | Operating normally. |
| | | Not lit | Unit has stopped exchanging data with the CPU Unit. |
| ERC (red) | Error detected by Unit | Lit | Data setting is out of range in the DM Area. |
| | | Not lit | Operating normally. |
| ERH (red) | Error in the CPU Unit | Lit | Error has occurred during data exchange with the CPU Unit, or Analog I/O Unit's unit number is set incorrectly, or there is a mounting error. |
| | | Not lit | Operating normally. |

Unit Number Switches

The CPU Unit and Analog Input Unit exchange data via words allocated to the Analog Input Unit as a Special I/O Unit. Words are allocated to Special I/O Units in both the CIO Area and the DM Area.

The words that each Analog I/O Unit uses are determined by the setting of the unit number switches on the front panel of the Unit.

Unit Number Switches

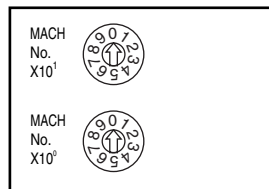

| Unit No. | CIO Area addresses | DM Area addresses |
|----------|--|---|
| 0 | CIO 2000 to CIO 2009 | D20000 to D20099 |
| 1 | CIO 2010 to CIO 2019 | D20100 to D20199 |
| 2 | CIO 2020 to CIO 2029 | D20200 to D20299 |
| 3 | CIO 2030 to CIO 2039 | D20300 to D20399 |
| 4 | CIO 2040 to CIO 2049 | D20400 to D20499 |
| 5 | CIO 2050 to CIO 2059 | D20500 to D20599 |
| 6 | CIO 2060 to CIO 2069 | D20600 to D20699 |
| 7 | CIO 2070 to CIO 2079 | D20700 to D20799 |
| 8 | CIO 2080 to CIO 2089 | D20800 to D20899 |
| 9 | CIO 2090 to CIO 2099 | D20900 to D20999 |
| 10 | CIO 2100 to CIO 2109 | D21000 to D21099 |
| to | to | to |
| n | CIO 2000 + n × 10 to CIO 2000 + n × 10 + 9 | D20000 + n × 100 to D20000 + n × 100 + 99 |
| to | to | to |
| 95 | CIO 2950 to CIO 2959 | D29500 to D29599 |

Note If two or more Special I/O Units are assigned the same unit number, a “UNIT No. DPL ERR” error (in the Programming Console) will occur (A401.13 will turn ON) and the PLC will not operate.

1-4-3 Exchanging Data with the CPU Unit

CS1W-PTS01-V1, PTS02/03/51/52, PTW01, PDC01, PTR01/02, PMV01/02, CJ1W-PTS51/52

The Analog I/O Unit exchanges data with the CPU Unit via the allocated portions of the CPU Unit's Special I/O Unit Area and DM Area. The addresses allocated in these areas are determined as follows, according to the value (0 to 95) set by the unit number switch on the front panel of the Analog I/O Unit.

- Special I/O Unit Area: 10 words from beginning word n
 $n = 2000 + \text{unit number (0 to 95)} \times 10$
- DM Area: 100 words from beginning word m
 $m = D20000 + \text{unit number (0 to 95)} \times 100$

The following table shows the addresses allocated according to the unit number.

| Unit No. | Special I/O Unit Area | DM Area |
|----------|-----------------------|------------------|
| 0 | CIO 2000 to CIO 2009 | D20000 to D20099 |
| 1 | CIO 2010 to CIO 2019 | D20100 to D20199 |
| 2 | CIO 2020 to CIO 2029 | D20200 to D20299 |
| 3 | CIO 2030 to CIO 2039 | D20300 to D20399 |
| 4 | CIO 2040 to CIO 2049 | D20400 to D20499 |
| 5 | CIO 2050 to CIO 2059 | D20500 to D20599 |
| 6 | CIO 2060 to CIO 2069 | D20600 to D20699 |
| 7 | CIO 2070 to CIO 2079 | D20700 to D20799 |
| 8 | CIO 2080 to CIO 2089 | D20800 to D20899 |
| 9 | CIO 2090 to CIO 2099 | D20900 to D20999 |
| 10 | CIO 2100 to CIO 2109 | D21000 to D21099 |
| to | to | to |
| 95 | CIO 2950 to CIO 2959 | D29500 to D29599 |

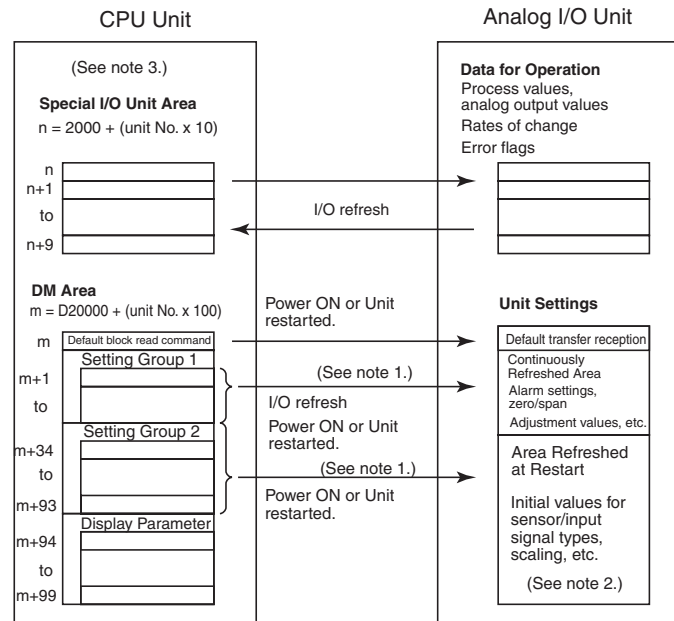

- Note**
1. This applies when word m contains other than 12345 (3039 hex), e.g., 0000 hex. When word m contains 12345 (3039 hex), the transfer direction will be reversed.
 2. The functions that can be used depend on the model.

3. The allocated data areas depend on the model.

These areas have the following functions for Analog I/O Units.

| | | | | | | | | | |
|--|---|-------------------------------|--|--|---|--|--|----------------------|--|
| Special I/O Unit Area | <p>The data for operation is continuously refreshed.</p> <p>The following types of data are transferred from Analog Input Units to the CPU Unit: Values scaled in industrial units for process values and rate-of-change values; alarm contact data, Input Disconnection Flag data, etc.</p> <p>Analog output values are transferred from the CPU Unit to Analog Output Units.</p> | | | | | | | | |
| DM Area | <p>Data is set in this area. The allocated portion of the DM Area is divided into the four areas shown below.</p> <p>Note For details, refer to the explanations for the individual Units.</p> <table border="1" data-bbox="727 555 1444 1406"> <tr> <td data-bbox="727 555 954 874">1) Default block read command</td> <td data-bbox="962 555 1444 874"> <p>When the PLC is turned ON or the Unit is restarted, the data in the Analog I/O Unit can be transferred back to the CPU Unit.</p> <p>Beginning word m is fixed.</p> <p>When word m contains 12345 (3039 hex), then the data is transferred from the Analog I/O Unit to the CPU Unit.</p> <p>When word m contains less than 12345 (3039 hex), such as 0 (0000 hex), then data is transferred from the CPU Unit to the Analog I/O Unit as usual.</p> </td> </tr> <tr> <td data-bbox="727 878 954 1176">2) Setting Group 1 (continuously refreshed area)</td> <td data-bbox="962 878 1444 1176"> <p>While the PLC is ON (even if the CPU Unit is operating), this area is continuously refreshed.</p> <p>This area is refreshed when the PLC is turned ON or the Unit is restarted.</p> <p>The area is refreshed regardless of the CPU Unit's operation mode (i.e., RUN, Monitor, or Program Mode).</p> <p>Alarm settings, zero/span adjustment values, and so on, are set here.</p> </td> </tr> <tr> <td data-bbox="727 1181 954 1357">3) Setting Group 2 (initial settings area)</td> <td data-bbox="962 1181 1444 1357"> <p>When word m contains anything other than 12345 (3039 hex), data is transferred once to this area from the CPU Unit when the PLC is turned ON or the Unit is restarted.</p> <p>Sensor types, process value scaling, alarm supplementary functions, etc., are set here.</p> </td> </tr> <tr> <td data-bbox="727 1361 954 1406">4) Display Parameter</td> <td data-bbox="962 1361 1444 1406"> <p>Data range error addresses are stored here. (See note.)</p> </td> </tr> </table> | 1) Default block read command | <p>When the PLC is turned ON or the Unit is restarted, the data in the Analog I/O Unit can be transferred back to the CPU Unit.</p> <p>Beginning word m is fixed.</p> <p>When word m contains 12345 (3039 hex), then the data is transferred from the Analog I/O Unit to the CPU Unit.</p> <p>When word m contains less than 12345 (3039 hex), such as 0 (0000 hex), then data is transferred from the CPU Unit to the Analog I/O Unit as usual.</p> | 2) Setting Group 1 (continuously refreshed area) | <p>While the PLC is ON (even if the CPU Unit is operating), this area is continuously refreshed.</p> <p>This area is refreshed when the PLC is turned ON or the Unit is restarted.</p> <p>The area is refreshed regardless of the CPU Unit's operation mode (i.e., RUN, Monitor, or Program Mode).</p> <p>Alarm settings, zero/span adjustment values, and so on, are set here.</p> | 3) Setting Group 2 (initial settings area) | <p>When word m contains anything other than 12345 (3039 hex), data is transferred once to this area from the CPU Unit when the PLC is turned ON or the Unit is restarted.</p> <p>Sensor types, process value scaling, alarm supplementary functions, etc., are set here.</p> | 4) Display Parameter | <p>Data range error addresses are stored here. (See note.)</p> |
| 1) Default block read command | <p>When the PLC is turned ON or the Unit is restarted, the data in the Analog I/O Unit can be transferred back to the CPU Unit.</p> <p>Beginning word m is fixed.</p> <p>When word m contains 12345 (3039 hex), then the data is transferred from the Analog I/O Unit to the CPU Unit.</p> <p>When word m contains less than 12345 (3039 hex), such as 0 (0000 hex), then data is transferred from the CPU Unit to the Analog I/O Unit as usual.</p> | | | | | | | | |
| 2) Setting Group 1 (continuously refreshed area) | <p>While the PLC is ON (even if the CPU Unit is operating), this area is continuously refreshed.</p> <p>This area is refreshed when the PLC is turned ON or the Unit is restarted.</p> <p>The area is refreshed regardless of the CPU Unit's operation mode (i.e., RUN, Monitor, or Program Mode).</p> <p>Alarm settings, zero/span adjustment values, and so on, are set here.</p> | | | | | | | | |
| 3) Setting Group 2 (initial settings area) | <p>When word m contains anything other than 12345 (3039 hex), data is transferred once to this area from the CPU Unit when the PLC is turned ON or the Unit is restarted.</p> <p>Sensor types, process value scaling, alarm supplementary functions, etc., are set here.</p> | | | | | | | | |
| 4) Display Parameter | <p>Data range error addresses are stored here. (See note.)</p> | | | | | | | | |

- Note**
- The ERC indicator on the Unit's front panel will light if an out-of-range setting is made in either Setting Group 1 or 2. The offset from word m to the first word containing the out-of-range error will be stored as the Data Range Error Address in the DM Area in four digits hexadecimal. When an error is made in Setting Group 1, the ERR indicator will light and the data range error address will be stored immediately. When an error is made in Setting Group 2, the ERC indicator will light when the PLC is turned ON again or the Unit is restarted and the data range error address will be stored at that time.
 - The functions that can be used depend on the model.

Transferring Analog I/O Unit Default Settings to the CPU Unit

When transferring the Analog I/O Unit's default settings to the CPU Unit's DM Area to be used for operation, store 12345 (3039 hex) in word m and either turn ON the power supply or restart the Unit. After the default settings have been transferred, the value in word m will be automatically returned to 0 (0000 hex). From that point onwards, the values stored in the DM Area will be transferred to the Analog I/O Unit for operation when the PLC is turned ON or the Unit is restarted.

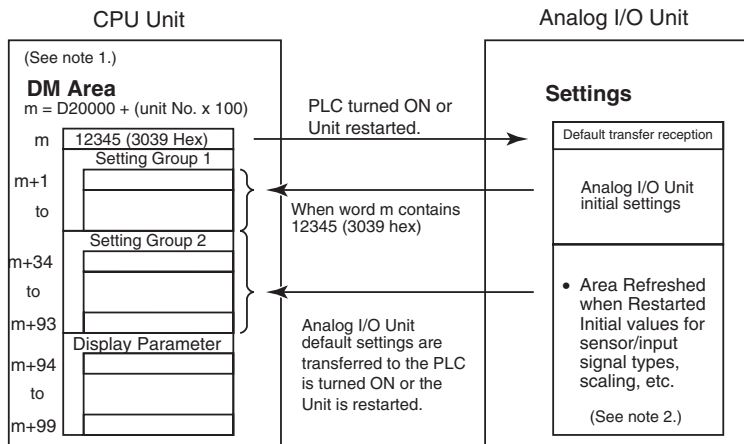

- Note**
1. The allocated data areas depend on the model.
 2. The functions that can be used depend on the model.

Restarting Special I/O Units

To restore operation after the contents of the DM Area have been changed, or after the cause of an error has been cleared, either turn ON the power supply to the PLC or turn the Special I/O Unit Restart Bit ON.

| Unit No. | DM Area allocation |
|----------|--------------------|
| 0 | A502.00 |
| 1 | A502.01 |
| to | to |
| 15 | A502.15 |
| to | to |
| 95 | A507.15 |

Note If an error is not cleared when the PLC is turned ON again or the Special I/O Unit Restart Bit is turned ON, replace the Unit.

CS1W-PTS11/12, PDC11 and CJ1W-PTS15/16, PDC15

These Units exchange data with the following CPU Unit areas:

- DM Area words allocated to the Unit as a Special I/O Unit
- CIO Area words allocated to the Unit as a Special I/O Unit
- Expansion Setting Area
- Expansion Control/Monitor Area

Set the addresses for these areas as follows:

| Area | Setting method |
|---|--|
| DM Area words allocated to the Unit as a Special I/O Unit | Set on the unit number switches (rotary switches) on the front of the Analog I/O Unit. |
| Data Area allocated to the Unit as a Special I/O Unit | |
| Expansion Setting Area | Set in words m+98 and m+99 in the DM Area. |
| Expansion Control/Monitor Area | Set in words o and o+1 in the Expansion Setting Area. |

Expansion Area addresses are determined as follows, according to the settings.

DM Area

A total of 100 words beginning with first word, word m ($m = D20000 + \text{unit number} (0 \text{ to } 95) \times 100$).

Special I/O Unit Area

A total of 10 words beginning with first word, word n ($n = 2000 + \text{unit number} (0 \text{ to } 95) \times 100$).

Expansion Setting Area

A total of 46 words (See note.) beginning with first word, word o ($o = \text{Word specified in word } m+99 \text{ in the area specified in word } m+98 \text{ in the DM Area}$).

Note The expansion setting area for a CJ-series PLC is 24 words from word o to word o+23.

Expansion Control/Monitor Area

A total of 35 words beginning with first word, word p. ($p = \text{address specified in word } o+1 \text{ in the area specified in word } o \text{ in the Expansion Setting Area}$).

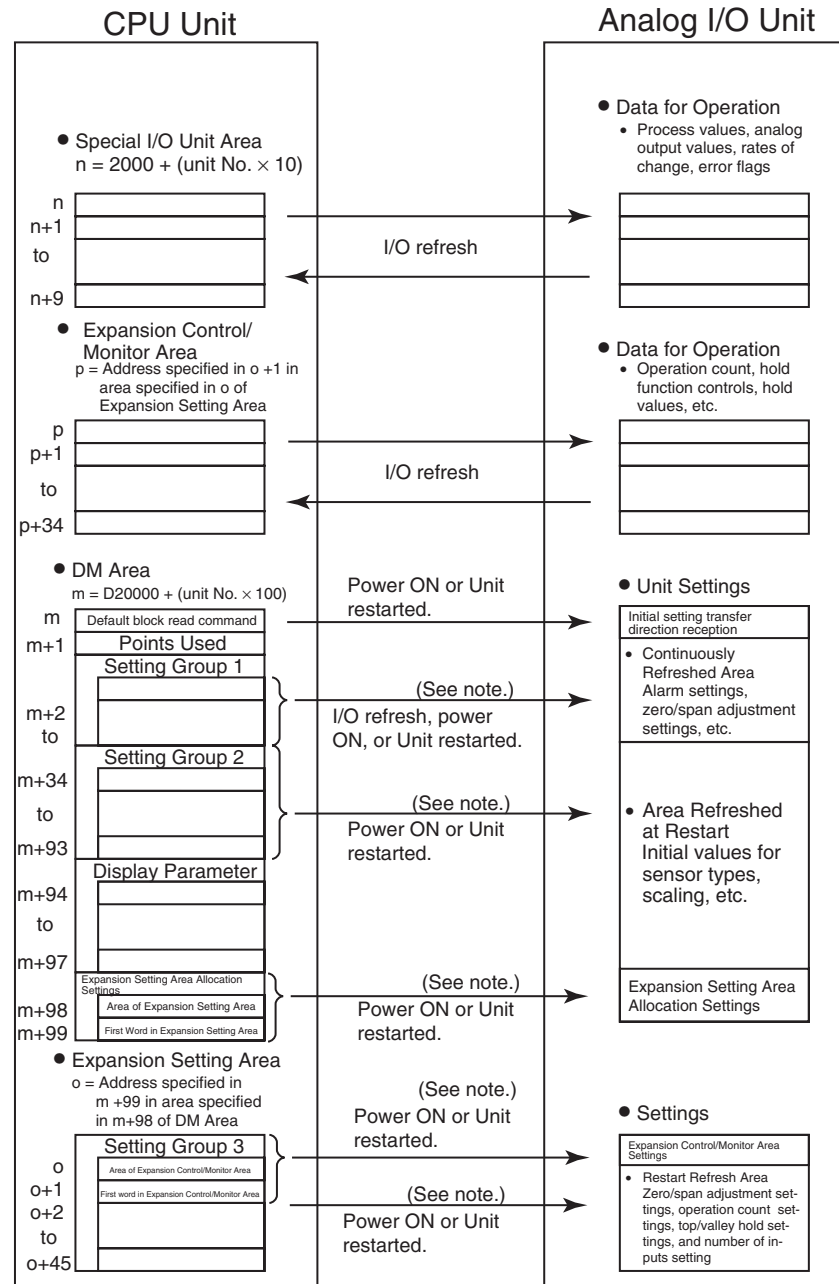

- Note**
1. This applies when word m contains other than 12345 (3039 hex), e.g., 0000 hex. When word m contains 12345 (3039 hex), the transfer direction will be reversed.
 2. The expansion setting area for a CJ-series PLC is 24 words from word o to word o+23.
 3. When specifying an expansion control/monitor area or an expansion setting area, be sure that it does not overlap with other areas that are being used. If areas overlap, the words that are allocated may be overwritten, resulting in unexpected operation.
 4. When specifying the first word in an expansion control/monitor area or an expansion setting area, be sure that the end of the memory area is not exceeded.

These areas have the following functions for Analog I/O Units.

| | |
|-----------------------|---|
| DM Area | <p>Data is set in this area. The allocated portion of the DM Area is divided into the five areas shown below.</p> <p>Note For details, refer to the explanations for the individual Units.</p> <p>1) Default block read command: When the PLC is turned ON or the Unit is restarted, the data in the Analog I/O Unit can be transferred back to the CPU Unit. Beginning word m contains fixed. When word m contains 12345 (3039 hex), then the data is transferred from the Analog I/O Unit to the CPU Unit. When word m contains less than 12345 (3039 hex), such as 0 (0000 hex), then data is transferred from the CPU Unit to the Analog I/O Unit as usual.</p> <p>2) Setting Group 1 (continuously refreshed area): While the PLC is ON (even if the CPU Unit is operating), this area is continuously refreshed. This area is refreshed when the PLC is turned ON or the Unit is restarted. The area is refreshed regardless of the CPU Unit's operation mode (i.e., RUN, Monitor, or Program Mode). Alarm settings, zero/span adjustment values, and so on, are set here.</p> <p>3) Setting Group 2 (initial settings area): Data is transferred once to this area from the CPU Unit when the PLC is turned ON or the Unit is restarted, unless word m contains 12345. Sensor types, process value scaling, alarm supplementary functions, etc., are set here.</p> <p>4) Display parameters: Data range error addresses are stored here. (See note.)</p> <p>5) Expansion Setting Area settings: Data is transferred once to this area from the CPU Unit when the PLC is turned ON or the Unit is restarted, as long as word m contains other than 12345. Expansion Setting Area settings are made here.</p> |
| Special I/O Unit Area | <p>The data in for operation is continuously refreshed.</p> <p>The following types of data are transferred from Analog I/O Units to the CPU Unit: Values scaled in industrial units for process values and rate-of-change values; alarm contact data, Input Disconnection Flag data, etc.</p> |

| | |
|--------------------------------|---|
| Expansion Setting Area | <p>Data for operation is continuously refreshed.</p> <p>Note For details, refer to the explanations for the individual Units.</p> <p>3) Setting Group 3 (initial settings area): Data is transferred once to this area from the CPU Unit when the PLC is turned ON or the Unit is restarted, as long as word m contains other than 12345 and the Expansion Setting Area settings are allocated (i.e., word m+98 contains other than 0). Expansion Control/Monitor Area settings, zero/span adjustment supplementary function, and so on, are set here.</p> |
| Expansion Control/Monitor Area | <p>Data for operation is continuously refreshed. Bits for beginning or resetting the hold function selection, adjustment period control, control bits, and so on, are transferred from the CPU Unit to the Analog Input Unit. Adjustment period notices, peak and bottom values, top and valley values, and so on, are transferred from the Analog Input Unit to the CPU Unit.</p> |

Note The ERC indicator on the Unit's front panel will light if an out-of-range setting is made in either Setting Group 1 or 2. The offset from word m to the first word containing the out-of-range error will be stored as the Data Range Error Address in the DM Area in four digits hexadecimal. If the first word containing the out-of-range error is in the Expansion Setting Area, the Data Range Error Address offset will be 100 words or more (e.g., 100 words for an error in the first word in the Expansion Setting Area). When an error is made in Setting Group 1, the ERR indicator will light and the data range error address will be stored immediately. When an error is made in Setting Group 2, the ERC indicator will light when the PLC is turned ON again or the Unit is restarted and the data range error address will be stored at that time.

Transferring Analog I/O Unit Default Settings to the CPU Unit

When transferring the Analog I/O Unit's default settings to the CPU Unit's DM Area and Expansion Setting Area used for operation, store 12345 (3039 hex) in word m and either turn the power supply OFF and ON or restart the Unit. After the default settings have been transferred, the value in word m will be automatically returned to 0 (0000 hex). From that point onwards, the values stored in the DM Area will be transferred to the Analog I/O Unit for operation when the PLC is turned ON or when the Unit is restarted.

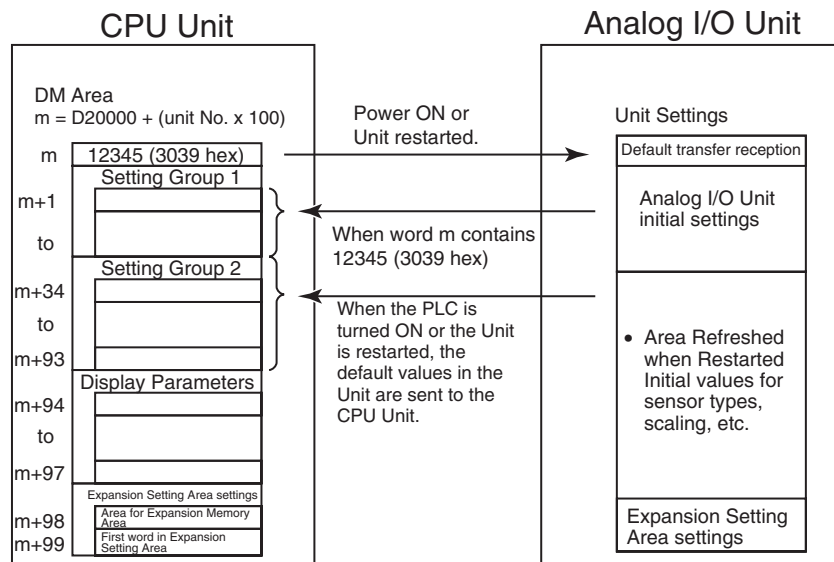

Restarting Special I/O Units

To restore operation after the contents of the DM Area have been changed, or after the cause of an error has been cleared, either turn ON the power supply to the PLC again or turn ON the Special I/O Unit Restart Bit ON.

| Unit No. | AR Area allocation |
|----------|--------------------|
| 0 | A502.00 |
| 1 | A502.01 |
| ... | ... |
| 15 | A502.15 |
| ... | ... |
| 95 | A507.15 |

Note If an error is not cleared when the PLC is turned ON again or the Special I/O Unit Restart Bit is turned ON, replace the Unit.

**CS1W-PTS55/56,
PDC55**

The Analog I/O Unit exchanges data with the CPU Unit via the allocated portions of the CPU Unit's Special I/O Unit Area and DM Area. The addresses allocated in these areas are determined as follows, according to the value (0 to 95) set by the unit number switch on the front panel of the Analog I/O Unit.

- Special I/O Unit Area: 10 words from beginning word n
 $n = 2000 + \text{unit number (0 to 95)} \times 10$
- DM Area: 100 words from beginning word m
 $m = D20000 + \text{unit number (0 to 95)} \times 100$
- Expansion Setting Area
 - CS1W-PTS55/PTS56
 Address specified in word m+60 in the area specified in word o in the Expansion Setting Area (one word only).
 - CS1W-PDC55
 Address specified in word m+84 in the area specified in word o in the Expansion Setting Area (one word only).

The following table shows the addresses allocated according to the unit number.

| Unit No. | Special I/O Unit Area | DM Area |
|----------|-----------------------|------------------|
| 0 | CIO 2000 to CIO 2009 | D20000 to D20099 |
| 1 | CIO 2010 to CIO 2019 | D20100 to D20199 |
| 2 | CIO 2020 to CIO 2029 | D20200 to D20299 |
| 3 | CIO 2030 to CIO 2039 | D20300 to D20399 |
| 4 | CIO 2040 to CIO 2049 | D20400 to D20499 |
| 5 | CIO 2050 to CIO 2059 | D20500 to D20599 |
| 6 | CIO 2060 to CIO 2069 | D20600 to D20699 |
| 7 | CIO 2070 to CIO 2079 | D20700 to D20799 |
| 8 | CIO 2080 to CIO 2089 | D20800 to D20899 |
| 9 | CIO 2090 to CIO 2099 | D20900 to D20999 |
| 10 | CIO 2100 to CIO 2109 | D21000 to D21099 |
| to | to | to |
| 95 | CIO 2950 to CIO 2959 | D29500 to D29599 |

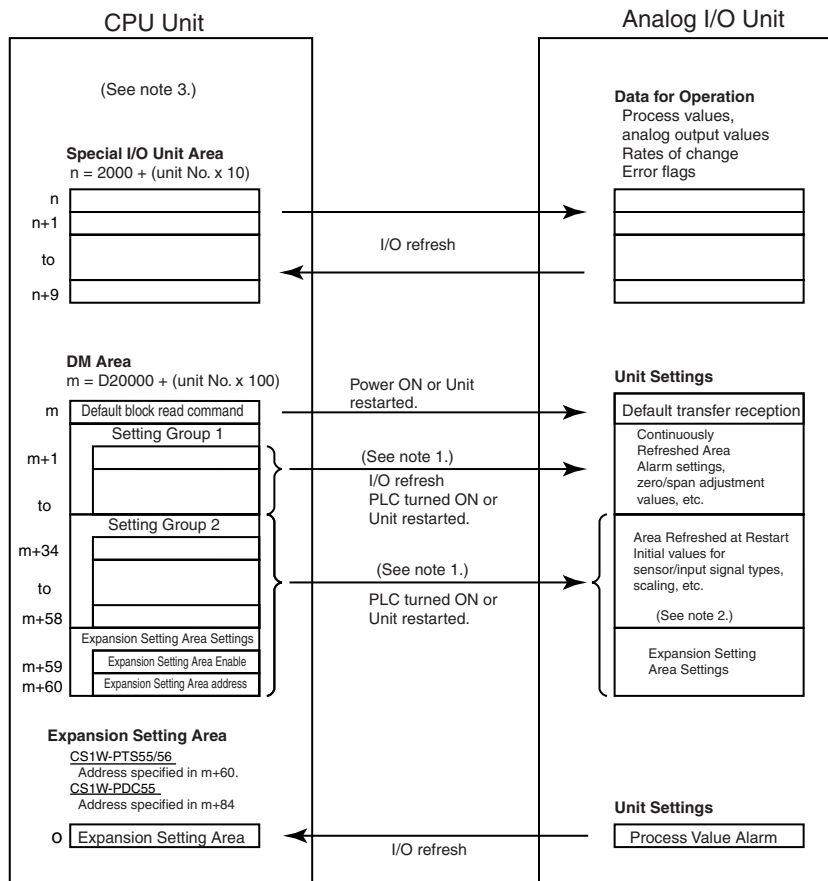

- Note**
1. This applies when word m contains other than 12345 (3039 hex), e.g., 0000 hex. When word m contains 12345 (3039 hex), the transfer direction will be reversed.
 2. The functions that can be used depend on the model.
 3. The allocated data areas depend on the model.

These areas have the following functions for Analog I/O Units.

| | |
|-----------------------|--|
| Special I/O Unit Area | <p>The data for operation is continuously refreshed.</p> <p>The following types of data are transferred from Analog Input Units to the CPU Unit: Values scaled in industrial units for process values and rate-of-change values; alarm contact data, Input Disconnection Flag data, etc.</p> <p>Analog output values are transferred from the CPU Unit to Analog Output Units.</p> |
|-----------------------|--|

| | | |
|------------------------|--|---|
| DM Area | Data is set in this area. The allocated portion of the DM Area is divided into the four areas shown below. Note For details, refer to the explanations for the individual Units. | |
| | 1) Default block read command | When the PLC is turned ON or the Unit is restarted, the data in the Analog I/O Unit can be transferred back to the CPU Unit. Beginning word m is fixed. When word m contains 12345 (3039 hex), then the data is transferred from the Analog I/O Unit to the CPU Unit. When word m contains less than 12345 (3039 hex), such as 0 (0000 hex), then data is transferred from the CPU Unit to the Analog I/O Unit as usual. |
| | 2) Setting Group 1 (continuously refreshed area) | While the PLC is ON (even if the CPU Unit is operating), this area is continuously refreshed. This area is refreshed when the PLC is turned ON or the Unit is restarted. The area is refreshed regardless of the CPU Unit's operation mode (i.e., RUN, Monitor, or Program Mode). Alarm settings, zero/span adjustment values, and so on, are set here. |
| | 3) Setting Group 2 (initial settings area) | When word m contains anything other than 12345 (3039 hex), data is transferred once to this area from the CPU Unit when the PLC is turned ON or the Unit is restarted. Sensor types, process value scaling, alarm supplementary functions, etc., are set here. |
| | 4) Display Parameter | Data range error addresses are stored here. (See note.) |
| Expansion Setting Area | Data for operation is continuously refreshed. Process Value Alarm | |

- Note**
1. The ERC indicator on the Unit's front panel will light if an out-of-range setting is made in either Setting Group 1 or 2. The offset from word m to the first word containing the out-of-range error will be stored as the Data Range Error Address in the DM Area in four digits hexadecimal. When an error is made in Setting Group 1, the ERR indicator will light and the data range error address will be stored immediately. When an error is made in Setting Group 2, the ERC indicator will light when the PLC is turned ON again or the Unit is restarted and the data range error address will be stored at that time.
 2. The functions that can be used depend on the model.

Transferring Analog I/O Unit Default Settings to the CPU Unit

When transferring the Analog I/O Unit's default settings to the CPU Unit's DM Area to be used for operation, store 12345 (3039 hex) in word m and either turn the power supply OFF and ON or restart the Unit. After the default settings have been transferred, the value in word m will be automatically returned to 0 (0000 hex). From that point onwards, the values stored in the DM Area will be transferred to the Analog I/O Unit for operation when the PLC is turned ON or the Unit is restarted.

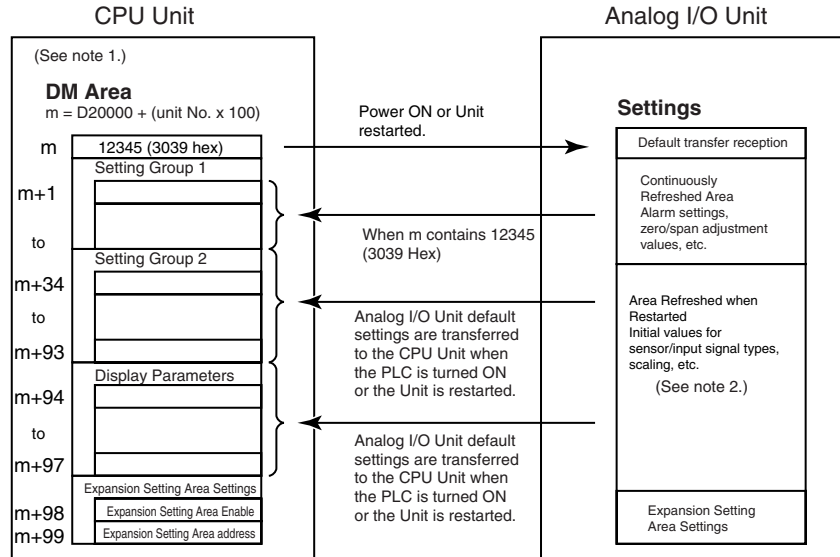

- Note**
1. The allocated data areas depend on the model.
 2. The functions that can be used depend on the model.

Restarting Special I/O Units

To restore operation after the contents of the DM Area have been changed, or after the cause of an error has been cleared, either turn ON the power supply to the PLC or turn ON the Special I/O Unit Restart Bit.

| Unit No. | DM Area allocation |
|----------|--------------------|
| 0 | A502.00 |
| 1 | A502.01 |
| to | to |
| 15 | A502.15 |
| to | to |
| 95 | A507.15 |

Note If an error is not cleared when the PLC is turned ON again or the Special I/O Unit Restart Bit is turned ON, replace the Unit.

CJ1W-PH41U

These Units exchange data with the following areas in the CPU Unit:

- DM Area words allocated to the Unit as a Special I/O Unit
- Special I/O Unit Area words in CIO Area
- Expansion Setting Area
- Expansion Control/Monitor Area

Set the addresses for these areas as follows:

| Area | Setting method |
|---|--|
| DM Area words allocated to the Unit as a Special I/O Unit | Set on the unit number switches (rotary switches) on the front of the Analog I/O Unit. |
| Special I/O Unit Area words in CIO Area | |

| Area | Setting method |
|--------------------------------|---|
| Expansion Setting Area | Set in words m+98 and m+99 in the DM Area. |
| Expansion Control/Monitor Area | Set in words o+32 and o+33 in the Expansion Setting Area. |

Allocated area addresses are determined as follows, according to the settings:

- DM Area: A total of 100 words beginning with first word, word m ($m = D20000 + \text{unit number (0 to 95)} \times 100$).
- Special I/O Unit Area: A total of 10 words beginning with first word, word n ($n = CIO 2000 + \text{unit number (0 to 95)} \times 10$).
- Expansion Setting Area: A total of 100 words beginning with first word, word o (o = Word specified in word m+99 in the area specified in word m+98, m+98 and m+99 are in the DM Area).
- Expansion Control/Monitor Area: A total of 46 words beginning with first word, word p (p = address specified in word o+33 in the area specified in word o+32, o+32 and o+33 are in the Expansion Setting Area).

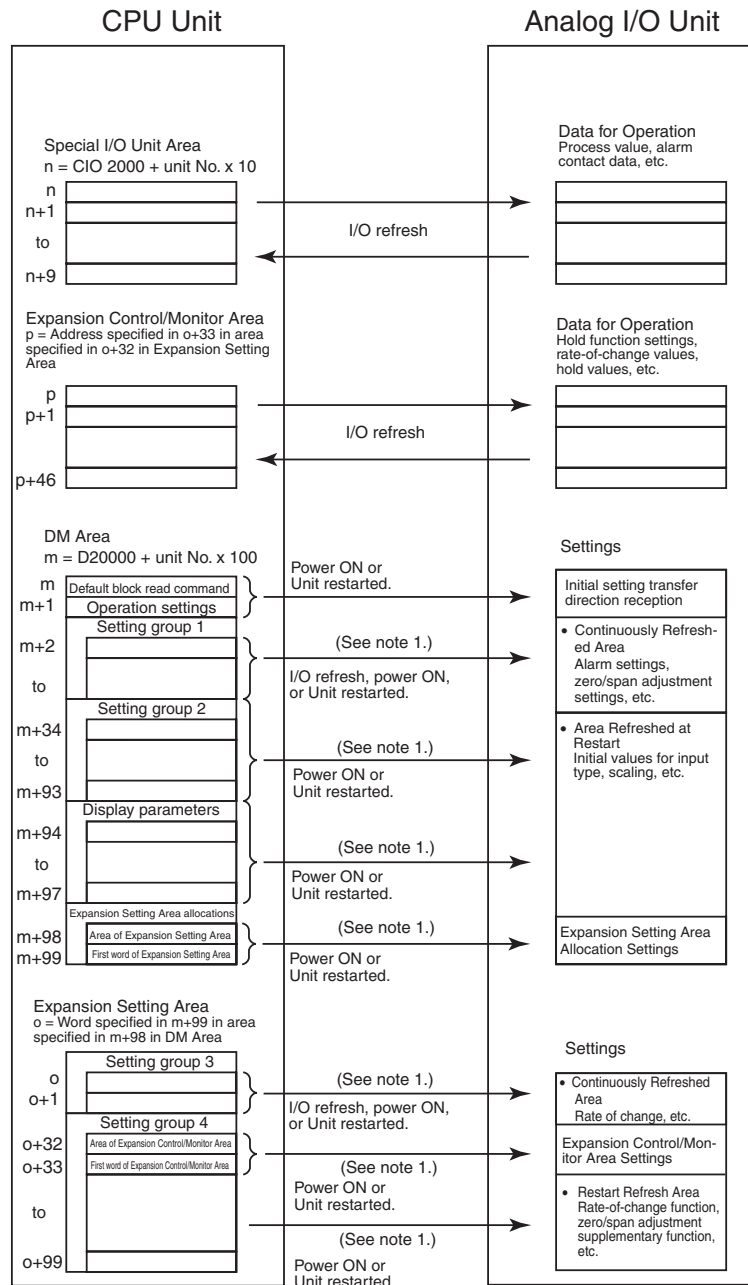

- Note**
1. This applies when word m contains other than 12345 (3039 hex), e.g., 0000 hex. When word m contains 12345 (3039 hex), the transfer direction will be reversed.
 2. When specifying the Expansion Control/Monitor Area or an Expansion Setting Area, be sure that it does not overlap with other words that are being used for another purpose. If areas overlap, the words that are allocated may be overwritten, resulting in unexpected operation.
 3. When specifying the first word in the Expansion Control/Monitor Area or the Expansion Setting Area, be sure that the end of the memory area is not exceeded.

These areas have the following functions for Analog I/O Units.

| | | | | | | | | | | | |
|--|--|-------------------------------|--|--|--|--|--|----------------------|--|------------------------------------|--|
| DM Area | <p>Data is set in this area. The allocated portion of the DM Area is divided into the five areas shown below.</p> <p>Note: For details, refer to the explanations for the individual Units.</p> <table border="1"> <tr> <td data-bbox="743 300 991 634">1. Default block read command</td> <td data-bbox="991 300 1442 634"> <p>When the power is turned ON or the Unit is restarted, the default data in the Analog I/O Unit can be read to the CPU Unit.</p> <ul style="list-style-type: none"> • Beginning word m is fixed. • When word m contains 12345 (3039 hex), then the data is transferred from the Analog I/O Unit to the CPU Unit. • When word m contains other than 12345 (3039 hex), e.g., 0 (0000 hex), then data is transferred from the CPU Unit to the Analog I/O Unit as usual. </td> </tr> <tr> <td data-bbox="743 634 991 910">2. Setting Group 1 (continuously refreshed area)</td> <td data-bbox="991 634 1442 910"> <p>While the PLC is ON (even if the CPU Unit is operating), this area is continuously refreshed. This area is also refreshed when the power is turned ON or the Unit is restarted. The area is refreshed regardless of the CPU Unit's operation mode (i.e., RUN, Monitor, or Program Mode). Alarm settings, zero/span adjustment values, etc., are set here.</p> </td> </tr> <tr> <td data-bbox="743 910 991 1108">3. Setting Group 2 (initial settings area)</td> <td data-bbox="991 910 1442 1108"> <p>When word m contains anything other than 12345 (3039 hex), data is transferred once to the Analog I/O Unit from the CPU Unit when the power is turned ON or the Unit is restarted. Input types, process value scaling, alarm supplementary functions, etc., are set here.</p> </td> </tr> <tr> <td data-bbox="743 1108 991 1172">4. Display Parameter</td> <td data-bbox="991 1108 1442 1172"> <p>Data range error addresses are stored here. (See note.)</p> </td> </tr> <tr> <td data-bbox="743 1172 991 1342">5. Expansion Setting Area settings</td> <td data-bbox="991 1172 1442 1342"> <p>Data is transferred once to the Analog I/O Unit from the CPU Unit when the power is turned ON or the Unit is restarted, as long as word m contains other than 12345. Expansion Setting Area settings are made here.</p> </td> </tr> </table> | 1. Default block read command | <p>When the power is turned ON or the Unit is restarted, the default data in the Analog I/O Unit can be read to the CPU Unit.</p> <ul style="list-style-type: none"> • Beginning word m is fixed. • When word m contains 12345 (3039 hex), then the data is transferred from the Analog I/O Unit to the CPU Unit. • When word m contains other than 12345 (3039 hex), e.g., 0 (0000 hex), then data is transferred from the CPU Unit to the Analog I/O Unit as usual. | 2. Setting Group 1 (continuously refreshed area) | <p>While the PLC is ON (even if the CPU Unit is operating), this area is continuously refreshed. This area is also refreshed when the power is turned ON or the Unit is restarted. The area is refreshed regardless of the CPU Unit's operation mode (i.e., RUN, Monitor, or Program Mode). Alarm settings, zero/span adjustment values, etc., are set here.</p> | 3. Setting Group 2 (initial settings area) | <p>When word m contains anything other than 12345 (3039 hex), data is transferred once to the Analog I/O Unit from the CPU Unit when the power is turned ON or the Unit is restarted. Input types, process value scaling, alarm supplementary functions, etc., are set here.</p> | 4. Display Parameter | <p>Data range error addresses are stored here. (See note.)</p> | 5. Expansion Setting Area settings | <p>Data is transferred once to the Analog I/O Unit from the CPU Unit when the power is turned ON or the Unit is restarted, as long as word m contains other than 12345. Expansion Setting Area settings are made here.</p> |
| 1. Default block read command | <p>When the power is turned ON or the Unit is restarted, the default data in the Analog I/O Unit can be read to the CPU Unit.</p> <ul style="list-style-type: none"> • Beginning word m is fixed. • When word m contains 12345 (3039 hex), then the data is transferred from the Analog I/O Unit to the CPU Unit. • When word m contains other than 12345 (3039 hex), e.g., 0 (0000 hex), then data is transferred from the CPU Unit to the Analog I/O Unit as usual. | | | | | | | | | | |
| 2. Setting Group 1 (continuously refreshed area) | <p>While the PLC is ON (even if the CPU Unit is operating), this area is continuously refreshed. This area is also refreshed when the power is turned ON or the Unit is restarted. The area is refreshed regardless of the CPU Unit's operation mode (i.e., RUN, Monitor, or Program Mode). Alarm settings, zero/span adjustment values, etc., are set here.</p> | | | | | | | | | | |
| 3. Setting Group 2 (initial settings area) | <p>When word m contains anything other than 12345 (3039 hex), data is transferred once to the Analog I/O Unit from the CPU Unit when the power is turned ON or the Unit is restarted. Input types, process value scaling, alarm supplementary functions, etc., are set here.</p> | | | | | | | | | | |
| 4. Display Parameter | <p>Data range error addresses are stored here. (See note.)</p> | | | | | | | | | | |
| 5. Expansion Setting Area settings | <p>Data is transferred once to the Analog I/O Unit from the CPU Unit when the power is turned ON or the Unit is restarted, as long as word m contains other than 12345. Expansion Setting Area settings are made here.</p> | | | | | | | | | | |
| CIO Area | <p>The data for operation is continuously refreshed. The following types of data are transferred from the Analog I/O Unit to the CPU Unit: Values scaled in industrial units for the process value, alarm contact data, Input Error Flag data, etc.</p> | | | | | | | | | | |

| | | |
|--------------------------------|---|---|
| Expansion Setting Area | Data is set in this area. Note: For details, refer to the explanations for the individual Units. | |
| | 1. Setting Group 3 (continuously refreshed area) | While the PLC is ON (even if the CPU Unit is operating), this area is continuously refreshed. This area is also refreshed when the power is turned ON or the Unit is restarted. The area is refreshed regardless of the CPU Unit's operation mode (i.e., RUN, Monitor, or Program Mode). Settings, such as the rate-of-change alarm setting, are set here. |
| | 2. Setting Group 4 (initial settings area) | Data is transferred once to the Analog I/O Unit from the CPU Unit when the power is turned ON or the Unit is restarted, as long as word m contains other than 12345 and the Expansion Setting Area settings are allocated (i.e., word m+98 contains other than 0). Expansion Control/Monitor Area settings, rate-of-change function, zero/span adjustment supplementary function, etc., are set here. |
| Expansion Control/Monitor Area | Data for operation is continuously refreshed. Bits for beginning or resetting the hold function selection, adjustment period control, control bits, etc., are transferred from the CPU Unit to the Analog I/O Unit. Adjustment period notice, peak and bottom values, top and valley values, and so on, are transferred from the Analog I/O Unit to the CPU Unit. | |

Note The ERC indicator on the Unit's front panel will light if an out-of-range setting is made in either Setting Group 1 (continuously refreshed area) or Setting Group 2 (initial settings area). The offset from word m to the first word containing the out-of-range error will be stored as the Data Range Error Address in the DM Area in four digits hexadecimal. If the first word containing the out-of-range error is in the Expansion Setting Area, the Data Range Error Address offset will be 100 words or more (e.g., 100 words for an error in the first word in the Expansion Setting Area).

When an error is made in Setting Group 1, the ERC indicator will light and the data range error address will be displayed immediately. When an error is made in Setting Group 2, the ERC indicator will light when the power is turned ON again or the Unit is restarted and the data range error address will be displayed at that time. For details, refer to *1-6 Error Processing*.

Transferring Analog I/O Unit Initial Settings to the CPU Unit

When transferring the Analog I/O Unit initial settings to the CPU Unit DM Area and Expansion Setting Area for operation, store 12345 (3039 hex) in word m and either again turn ON the power supply or restart the Unit. After the default settings have been transferred, the value in word m will be automatically returned to 0 (0000 hex). From that point onwards, the values stored in the DM Area will be transferred to the Analog I/O Unit for operation when the power is turned ON or the Unit is restarted.

The Analog I/O Unit holds the default settings, and they cannot be overwritten.

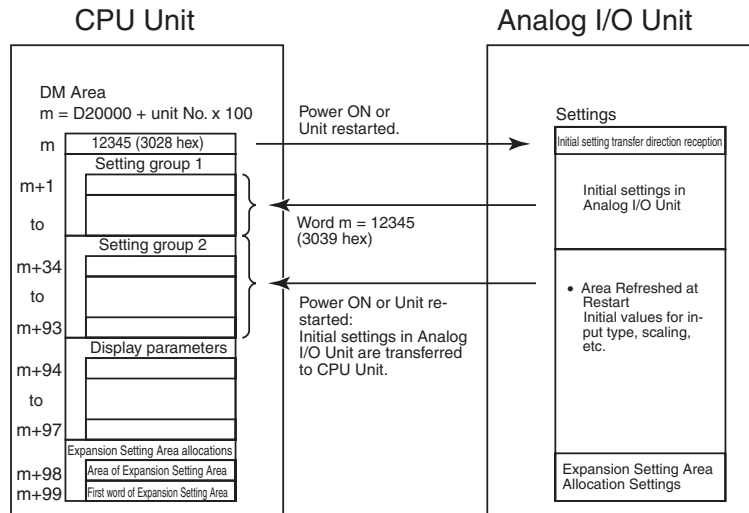

Restarting Special I/O Units

To restart Unit operation after the contents of the DM Area have been changed, or after the cause of an error has been cleared, either turn ON the power supply to the PLC again or turn ON the Special I/O Unit Restart Bit.

| Unit No. | Restart Bit |
|----------|-------------|
| 0 | A502.00 |
| 1 | A502.01 |
| to | to |
| 15 | A502.15 |
| to | to |
| 95 | A507.15 |

Note If an error is not cleared when the power is turned ON again or the Special I/O Unit Restart Bit is turned ON, replace the Analog I/O Unit.

1-4-4 Mounting the Units

CS Series

Use the following procedure to mount the CS-Series Analog I/O Unit to the Backplane.

- 1,2,3... 1. Mount the Unit to the Backplane by attaching it with the top and bottom hooks.

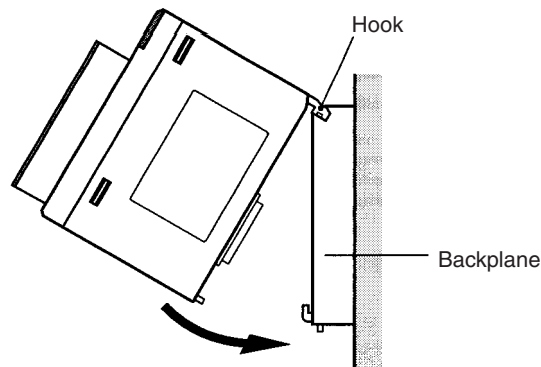

2. Properly insert each Unit into the Backplane connector, and tighten the screws on the bottom of the Unit to a torque of 0.4 N-m.

3. To remove a Unit, loosen the screws and lift it off.

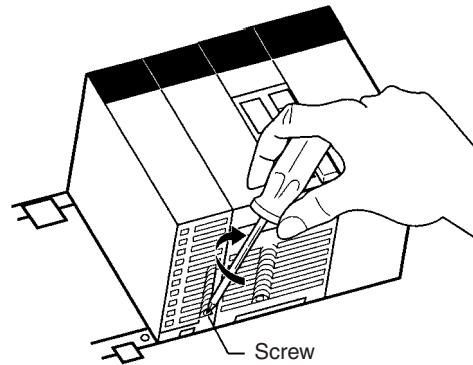

Note To allow for mounting and removal of Units, leave at least 20 mm of space between Units, as shown in the following diagram.

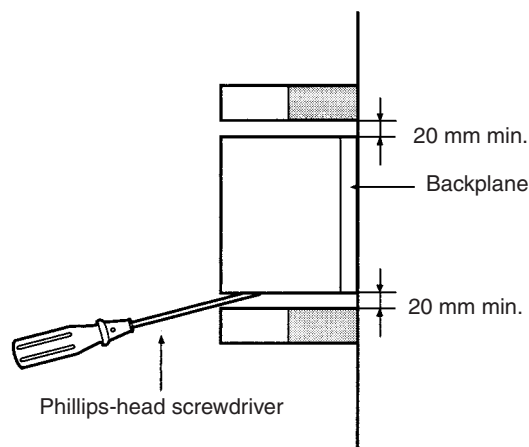

CJ Series

Use the following procedure to connect Analog I/O Units to a CJ-series Rack.

- 1,2,3... 1. Align the connectors and press in firmly on the Units to connect them completely.

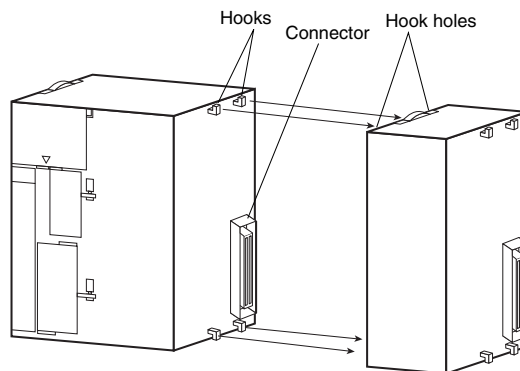

2. Move the sliders on the top and bottom of the Unit to the lock position to secure the Units. The sliders should click into place.

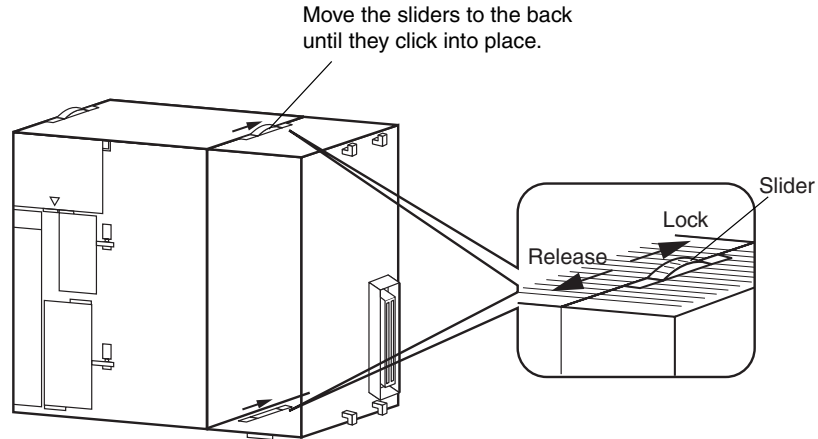

3. Attach an End Cover to the Unit on the right end of the Rack.

Note The CJ-series PLC may not operate properly if the sliders are not locked firmly into place.

1-4-5 Precautions when Handling Units

CS Series

Turn OFF the power to the PLC before mounting or removing Units, or connecting or disconnecting wiring.

To prevent adverse effects from noise, place I/O wiring in separate ducts from high-voltage or power lines.

Always ground the GR terminal on the Power Supply Unit of the PLC.

When wiring, leave the label on the Unit's top panel in place to prevent foreign objects such as wire clippings from dropping into the Unit. The label must be removed after wiring or the Unit will overheat.

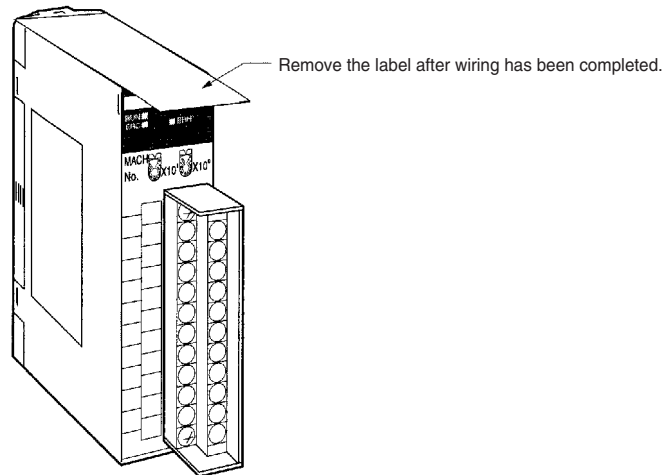

CJ Series

Be sure to turn OFF the power supply to the PLC before installing or disconnecting Units or connecting lines.

To reduce the risk of malfunctioning due to electrical noise, wire input and output lines in separate ducts from high-voltage and power lines.

When wiring a Unit, place a label over the top of the Unit to prevent wire clippings or other materials from getting inside the Unit. When the wiring has been completed, the label must be removed to prevent heat radiation.

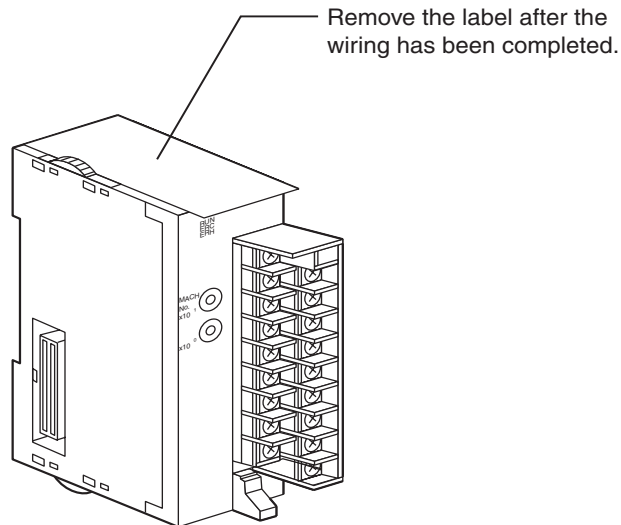

Precautions in Handling Removable Terminal Blocks

- The terminal block is removable. Press the lever on the bottom of the terminal block to remove the terminal block.
- During normal use, check that the lever is raised and the terminal block is locked in place.

Note Precautions for Terminal Blocks on Thermocouple Input Units and CJ1W-PH41U Isolated-type Universal Input Units

- Thermocouple Input Units and CJ1W-PH41U Isolated-type Universal Input Units have cold junction compensators. The specified accuracy will be as specified only when the cold junction compensator (i.e., the terminal block) and the Unit are used as a set. Always use the terminal block and the Unit as a set. Both the CJ1W-PTS51 Unit terminal block and this Unit have labels on them providing the serial number.
- If repairs are required to the Unit, always return the terminal block (including the cold junction compensator) with the Unit.

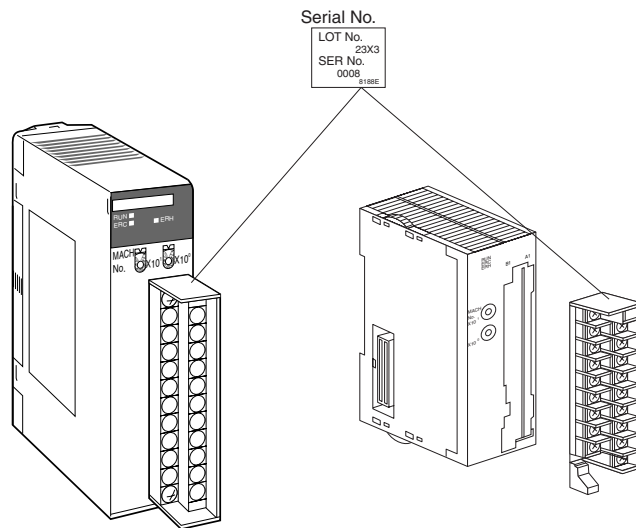

1-4-6 Connecting Crimp Terminals

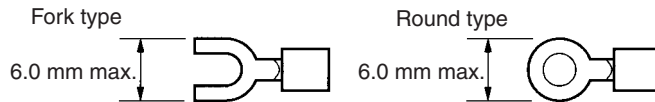
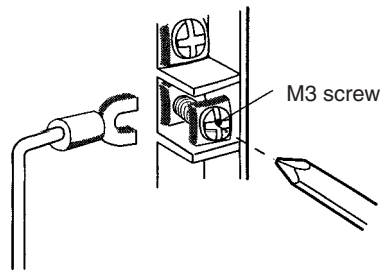

Note Tighten the terminal screws securely to a torque of 0.5 N·m. Loose screws may result in conversion errors.

1-4-7 Dimensions

CS Series

CS1W-P□□0□/1□/51/52

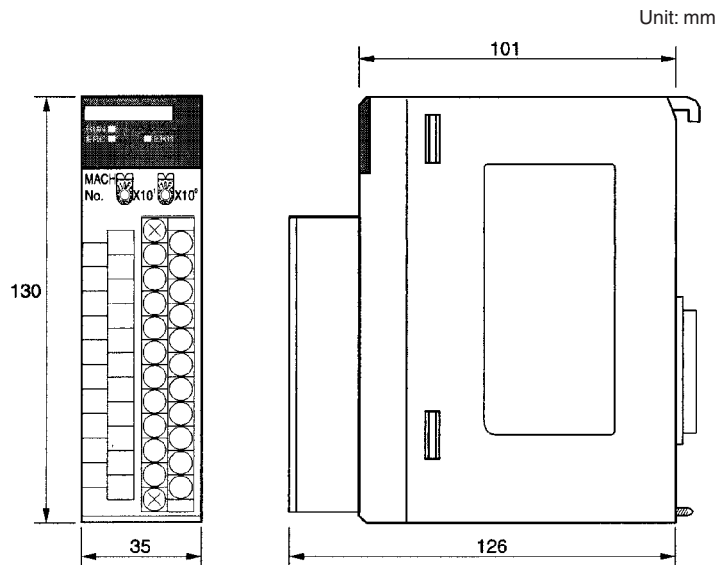

■ Terminal Block Dimensions

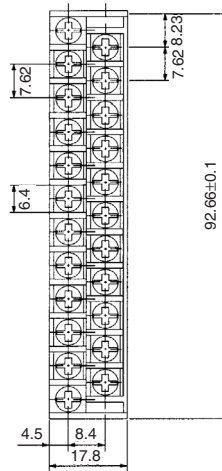

CS1W-PTS55/56/PDC55

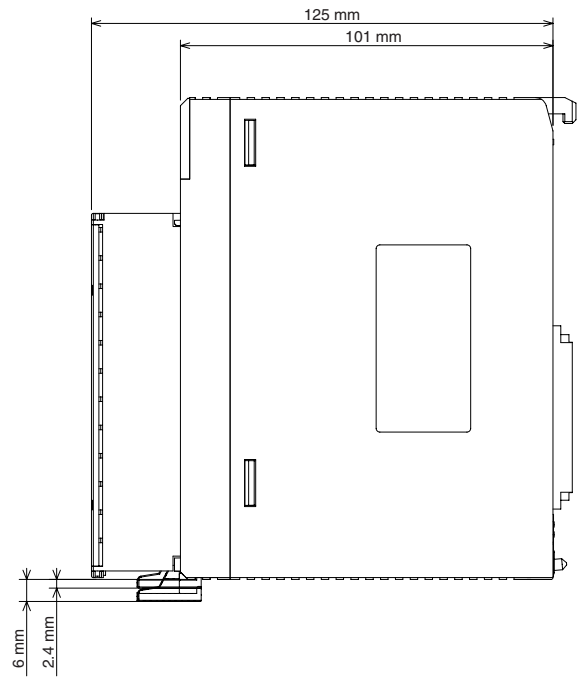
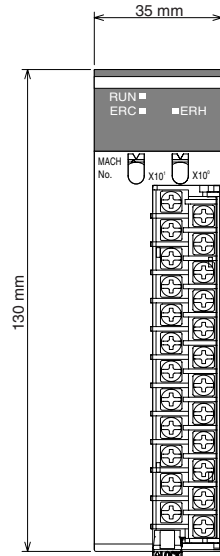

■ Terminal Block Dimensions

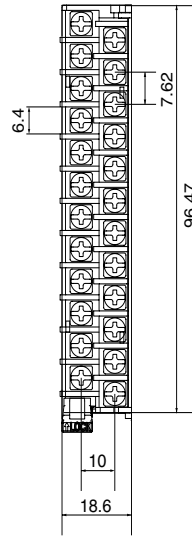

CJ Series

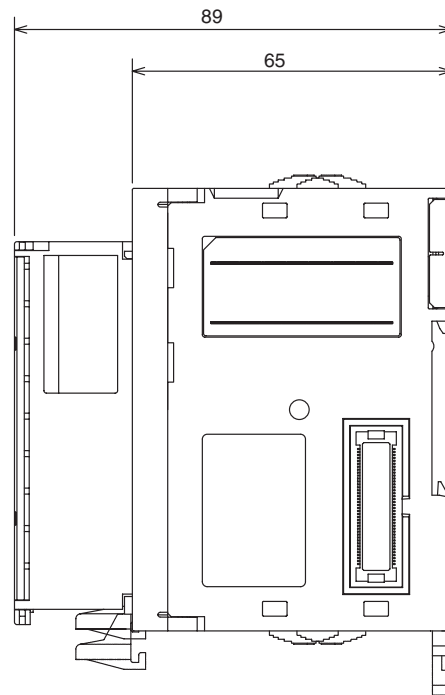
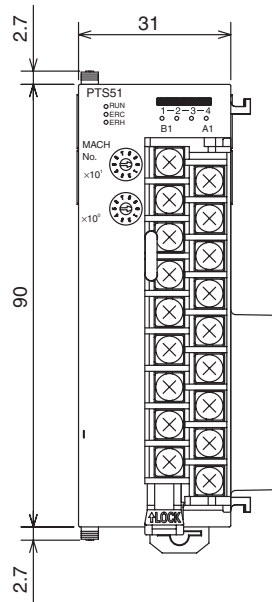

1-5 Operating Procedures

Use the following procedures to operate the Analog I/O Unit. The procedures are the same for all models.

Initial Setup (Hardware)

- 1,2,3...**
1. Set the unit number, using the rotary switches on the front panel of the Unit.
 2. Mount the Unit to either a CPU Rack or Expansion Rack.
A maximum of 80 Units for the CS Series and 40 Units for the CJ Series can be mounted in a basic System (with no restrictions on mounting location).
 3. Connect sensors or external control units.
 4. Connect a Programming Device to the PLC.
 5. Turn ON the power to the PLC.
 6. Create the I/O tables.
 7. Allow time for warmup (see note).

Note Analog I/O Units require time to warm up after the PLC is turned ON. Warmup times differ for each Unit, as shown in the following table.

| Model | Warmup time |
|------------------------------|--|
| CS1W-PTS01-V1/11, CJ1W-PTS15 | 45 min |
| CS1W-PTS5□, CJ1W-PTS5□ | 30 min |
| CJ1W-PH41U | Resistance thermometer inputs: 30 min Thermocouple, ±100-mV user-set range inputs: 45 min Current and voltage inputs (not including ±100-mV user-set range inputs): 30 min Potentiometer inputs: 10 min |
| Other Analog I/O Units | 10 min |

Initial Software Setup

- 1,2,3...**
1. Make the initial settings in the DM Area (m to m+99).
 - When using the Unit's default values, set word m to 12345 (3039 hex).
 - When using data from the CPU Unit's DM Area, set word m to a value other than 12345 (3039 hex), such as 0000 hex.
 2. Turn the power OFF and then back ON again, or turn ON the Special I/O Unit Restart Bit.

Ladder Diagram Program

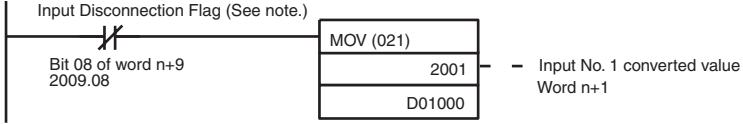
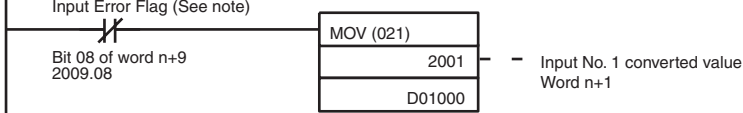
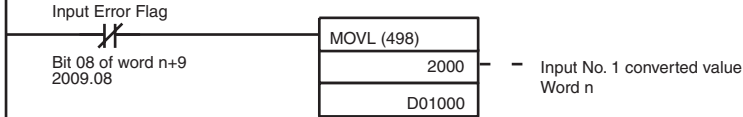
| Name | Model | Basic ladder diagram programming |
|--|---|---|
| Isolated-type Thermocouple Input Unit | CS1W-PTS01-V1 CS1W-PTS11/51 CS1W-PTS55 CJ1W-PTS51/15 | <p>Reading the converted value using MOV(021) with the Input Disconnection Flag's NC condition as the input condition.</p>  |
| Isolated-type Resistance Thermometer Input Unit (Pt100, JPt100) | CS1W-PTS02 | <p>Note: Bit 00 of word n +9 (CIO 2009.00 for unit number 00) is the Sensor Error Flag for CS1W-PTS5□ and CJ1W-PTS5□.</p> |
| Isolated-type Resistance Thermometer Input Unit (Ni508.4) | CS1W-PTS03 | |
| Isolated-type Resistance Thermometer Input Unit (Pt100, JPt100, Pt50, Ni508.4) | CS1W-PTS12 CJ1W-PTS16 | |
| Isolated-type Resistance Thermometer Input Unit (Pt100, JPt100) | CS1W-PTS52 CS1W-PTS56 CJ1W-PTS52 | |
| Isolated-type 2-Wire Transmitter Input Unit | CS1W-PTW01 | <p>Reading the converted value using MOV(021) with the Input Error Flag's NC condition as the input condition.</p> |
| Isolated-type Direct Current Input Unit | CS1W-PDC01 CS1W-PDC11 CJ1W-PDC15 CS1W-PDC55 |  <p>Note: Bit 00 of word n +9 (CIO 2009.00 for unit number 00) is the Sensor Error Flag for CS1W-PDC5□.</p> |
| Power Transducer Input Unit | CS1W-PTR01 | <p>Reading the converted value using MOV(021).</p> |
| Isolated-type Pulse Input Unit | CS1W-PPS01 | |
| Analog Input Unit (100 mW) | CS1W-PTR02 | |
| Isolated-type Analog Output Unit | CS1W-PMV01 CS1W-PMV02 | <p>Writing the value to convert using MOV(021). After writing, then checking of the answer input value and output disconnection.</p> <p>Writing the value to convert using MOV(021).</p> |
| Isolated-type Universal Input Unit | CJ1W-PH41U | <p>Reading the converted value using MOVL(498) with the Input Error Flag's NC condition as the input condition.</p>  |

1-6 Error Processing

The following table shows the contents of the LED indicator displays on the front panel of the Analog I/O Unit. The contents shown here are the same for all models. For error processing specific to each Unit, refer to the explanations for the individual Units.

Errors Detected by the Analog I/O Unit

| ERC LED (red) | RUN LED (green) | Contents | Probable cause | Unit operation | Remedy |
|---------------|-----------------|---|--|---|---|
| Lit | Lit | Setting Group 1 (continuously refreshed area) error (See note 1.) | The Analog I/O Unit started up and was operating properly, but an out-of-range setting was made in Setting Group 1 in the DM Area. | The Unit continues operating with the Setting Group 1 data prior to the change. | Restore the set value to within the allowable range. (There is no need to turn the power supply OFF and ON or to restart the Unit.) |
| | Not lit | Setting Group 1 (See note 1.), Setting Group 2 (See note 2.) error, or Expansion Setting Area (See note 3.) | An out-of-range setting was made for either Setting Group 1 or Setting Group 2 in the DM Area. | The Unit will not start up. | Restore the set value to within the allowable range, and then either turn the power supply OFF and ON or restart the Unit. |

Note 1. The following table shows the processing and results for Setting Group 1.

| Processing | Result | LED indicators on Unit | Data range error address stored in DM Area |
|--|--|--|--|
| When an out-of-range setting is made in Setting Group 1 during operation | The Unit continues to operate with the Setting Group 1 data prior to the change. | ERC indicator is lit. RUN indicator remains lit. | The lowest DM address where the out-of-range error occurred is stored, in four digits hexadecimal, as the offset value from m (i.e., the number of added words). |
| ↓ | | | |
| When the setting is changed within the allowable range during operation | The Unit operates with the Setting Group 1 data after the change. | ERC indicator is not lit. RUN indicator remains lit. | If there is no other error, 0000 hex is stored. (If there is another error, the offset value for that DM address is stored.) |
| When the PLC is turned ON or the Unit is restarted with an error still in effect. | The Unit will not start up. | ERC indicator is lit. RUN indicator is not lit. | The lowest DM address where the out-of-range error occurred is stored, in four digits hexadecimal, as the offset value from m (i.e., the number of added words). |
| ↓ | | | |
| When the setting is made within the allowable range, and the PLC is turned ON or the Unit is restarted | The Unit starts up normally. | ERC indicator is not lit. RUN indicator is lit. | If there is no other error, 0000 hex is stored. (If there is another error, the offset value for that DM address is stored.) |

2. The following table shows the processing and results for Setting Group 2.

| Processing | Result | LED indicators on Unit | Data range error address stored in DM Area |
|--|--|--|--|
| When an out-of-range setting is made in Setting Group 2 during operation | The Unit operates with the Setting Group 2 data prior to the change. | ERC indicator is not lit. RUN indicator remains lit. | If there is no other setting error, 0000 hex remains stored. (If there is another setting error, the offset value for that DM address is stored.) |
| ↓ | | | |
| When the PLC is turned ON or when the Unit is restarted | The Unit will not start up. | ERC indicator is lit. RUN indicator is not lit. | The lowest DM address where the out-of-range error occurred is stored, in four digits hexadecimal, as the offset value from m (i.e., the number of added words). |
| ↓ | | | |
| When the setting is made within the allowable range, and the PLC is turned ON or the Unit is restarted | The Unit starts up normally. | ERC indicator is not lit. RUN indicator is lit. | If there is no other error, 0000 hex is stored. (If there is another error, the offset value for that DM address is stored.) |

Errors Related to the CPU Unit

The ERH indicator will be lit red for all of the following errors.

| ERH LED (red) | RUN LED (green) | Contents | Probable cause | Error type | Detailed cause | Input Unit status (See note 1.) | Output Unit status (See note 2.) | Remedy |
|---------------|-----------------|--|--|---|---|---|--|---|
| Lit | Lit | Error in data exchange with the CPU Unit | During normal operation, an I/O bus error, CPU Unit monitoring error, or WDT error occurred at the CPU Unit. | I/O bus error | A data transmission error occurred between the CPU Unit and the Analog I/O Unit. | Converted data becomes 0000 hex. External alarm output: No output. (See note 3.) | Depending on the output hold status, either the set values prior to the error or preset values will be held. | Turn OFF the power supply and check the installation conditions and the cable connections between devices. Then turn the power back ON. |
| | | | | CPU Unit monitoring error | The CPU Unit did not respond within a fixed period of time. | Maintains the status existing before the error. External alarm output: Output. (See note 3.) | Held at status existing before the error. | |
| | | | | CPU Unit WDT error | WDT error has been generated at CPU Unit. | Changes to undefined state. External alarm output: No output. (See note 3.) | Depending on the output hold status, either the set values prior to the error or preset values will be held. | |
| Not lit | Not lit | Error in Analog I/O Unit's unit number or mounting | Either the unit number is set incorrectly or the Unit is mounted incorrectly. | Duplicate Unit Number | The same unit number has been assigned to more than one Unit or the unit number was set to a value other than 00 to 95. | Conversion does not start. External alarm output: No output. (See note 3.) | 0 mA or 0 V will be output. | Reset the unit number so that it will not duplicate any other. |
| | | | | Special I/O Unit Setting Error | The Analog I/O Units registered in the I/O table are different from the ones actually mounted. | | | Check the mounting positions, and either mount the Units according to the I/O table or correct the I/O table. |
| | | | | Fatal error at CPU Unit after turning ON the power supply | | | | |

- Note** 1. Applicable Units:
 CS1W-PTS01-V1/PTS11/PTS51/PTS55 and CJ1W-PTS51/15 Isolated-type Thermocouple Input Units
 CS1W-PTS02/PTS03/PTS12/PTS52/PTS56 and CJ1W-PTS52/16 Isolated-type Resistance Thermometer Input Units
 CS1W-PTW01 Isolated-type 2-Wire Transmitter Input Unit
 CS1W-PDC01/PDC11/PDC55, PTR02, and CJ1W-PDC15 Isolated-type Direct Current Input Units

CS1W-PTR01 Power Transducer Input Unit

CS1W-PTR02 Analog Input Unit (100 mV)

CS1W-PPS01 Isolated-type Pulse Input Unit.

CJ1W-PH41U Isolated-type Universal Input Units

2. Applicable Unit: CS1W-PMV01 Isolated-type Analog Output Unit.
3. Indicates the external alarm output status for CS1W-PTS51/PTS52 and CJ1W-PTS51/PTS52. The alarm outputs will operate normally even if all loads are turned OFF from the CPU Unit.
4. If either of the following changes is made for the Expansion Setting Area for the CJ1W-PTS15/-PTS16/-PDC15/-AD04U/-PH41U, the previous data will be left in the Expansion Setting Area even after the change has been made.

Clear the previous data when changing either of these settings.

- The Expansion Setting Area allocation is disabled.
- The Expansion Setting Area Address setting is changed while the Expansion Setting Area allocation is enabled.

1-7 Specification Changes

1-7-1 CS1W-PTS01-V1, CS1W-PTS02/PTS03, CS1W-PTW01, CS1W-PDC01, CS1W-PPS01, and CS1W-PMV01

The specifications of the following I/O Units with the lot number 000426 XXXX or later (manufactured since April 26, 2000) have been changed as shown in the table below.

Overview

| Name | Model | Main changes |
|---|---------------|--|
| Isolated-type Thermocouple Input Unit | CS1W-PTS01-V1 | <ul style="list-style-type: none"> Improved effective resolution: From the equivalent of 10 bits to 1/4,096 Improved rate-of-change calculation: Refer to <i>Improvement in Rate-of-change Calculation Method</i> below for details. |
| Isolated-type Resistance Thermometer Input Unit | CS1W-PTS02 | <ul style="list-style-type: none"> Improved effective resolution: From the equivalent of 10 bits to 1/4,096 Improved rate-of-change calculation: Refer to <i>Improvement in Rate-of-change Calculation Method</i> below for details. |
| Isolated-type Resistance Thermometer Input Unit (Ni508.4 Ω) | CS1W-PTS03 | <ul style="list-style-type: none"> Improved effective resolution: From the equivalent of 11 bits to 1/4,096 Improved rate-of-change calculation: Refer to <i>Improvement in Rate-of-change Calculation Method</i> below for details. |
| Isolated-type 2-Wire Transmitter Input Unit | CS1W-PTW01 | <ul style="list-style-type: none"> Improved effective resolution: From the equivalent of 10 bits to 1/4,096 Improved rate-of-change calculation: Refer to <i>Improvement in Rate-of-change Calculation Method</i> below for details. Reduced 26-V consumption current: 0.4 A to 0.16 A |
| Isolated-type Direct Current Input Unit | CS1W-PDC01 | <ul style="list-style-type: none"> Improved effective resolution: From the equivalent of 10 bits to 1/4,096 Improved rate-of-change calculation: Refer to <i>Improvement in Rate-of-change Calculation Method</i> below for details. Added input range: 0 to 20 mA (Refer to <i>New Input Range (0 to 20 mA) for the CS1W-PDC01</i> for details.) |
| Isolated-type Pulse Input Unit | CS1W-PPS01 | <ul style="list-style-type: none"> Changed instantaneous value setting method and added time unit setting function (Refer to <i>Instantaneous Value Measurement and Measurement Time Unit Setting for CS1W-PPS01</i> for details.) Reduction of 26 V consumption current: 0.22 A to 0.16 A |
| Isolated-type Analog Output Unit | CS1W-PMV01 | <ul style="list-style-type: none"> Improved resolution (answer back input): From the equivalent of 9 bits to 1/2000 |

Details

Improvement in Rate-of-change Calculation Method

Before Change

The current process value was compared with the value before the time set by the comparison time interval and the difference between them was divided by the comparison time interval to find the rate-of-change per second. When the difference was small, the calculated value turned out to be so small that it was hard to identify the change.

After Change

The current process value is compared with the value before the time set by the comparison time interval and the difference is output. When the difference is small, the comparison time interval can be set longer so that the change can be easily identified.

New Input Range (0 to 20 mA) for the CS1W-PDC01

Before Change

-10 to 10 V, 0 to 10 V, -5 to 5 V, 0 to 5 V, 1 to 5 V, 4 to 20 mA, user-set voltages

After Change

-10 to 10 V, 0 to 10 V, -5 to 5 V, 0 to 5 V, 1 to 5 V, 4 to 20 mA, user-set voltages, 0 to 20 mA (new)

The settings are shown below. (There is no need to change the setting unless the new setting is going to be used.)

- Before Change (m = D20000 + Unit number x 100)

| Offset | | | | Setting range | Setting name |
|-------------|-------------|-------------|-------------|---------------|--|
| Input No. 1 | Input No. 2 | Input No. 3 | Input No. 4 | | |
| m+34 | m+48 | m+62 | m+76 | 0 to 6 | Input signal 0: -10 to +10 V, 1: 0 to 10 V, 2: -5 to 5 V, 3: 0 to 5 V, 4: 1 to 5 V, 5: 4 to 20 mA, 6: User-set voltages |

- After Change (m = D20000 + Unit number x 100)

| Offset | | | | Setting range | Setting name |
|-------------|-------------|-------------|-------------|---------------|---|
| Input No. 1 | Input No. 2 | Input No. 3 | Input No. 4 | | |
| m+34 | m+48 | m+62 | m+76 | 0 to 7 | Input signal 0: -10 to +10 V, 1: 0 to 10 V, 2: -5 to 5 V, 3: 0 to 5 V, 4: 1 to 5 V, 5: 4 to 20 mA, 6: User-set voltages 7: 0 to 20 mA |

Instantaneous Value Measurement and Measurement Time Unit Setting for CS1W-PPS01

Instantaneous Value Measurement

Before Change

The number of pulses per second was output as an instantaneous value. To calculate the value, the number of pulses per 0.1 second was multiplied by 10. For pulses less than 10 Hz, 10 pulses/second and 0 pulses/second were alternately output due to inaccurate calculations.

After Change

The number of pulses per second is counted for that one second and output as is. This allows calculation of pulses down to 1 Hz.

Measurement Time Unit Setting

This new function allows setting of measurement time unit to enable measuring pulses with much slower frequencies. Measurement time unit can be set to 1, 3, 10, 30, or 60 s.

The settings are shown below. (There is no need to change the setting if the current unit of 1 s is going to be used.)

- Before Change (m = D20000 + Unit number x 100)

| Offset | | | | Setting range | Setting name |
|-------------|-------------|-------------|-------------|-----------------------|---|
| Input No. 1 | Input No. 2 | Input No. 3 | Input No. 4 | | |
| m+30 | m+38 | m+46 | m+54 | Bits 00 to 03: 0 to 3 | Decimal point position from right of instantaneous value conversion coefficient |
| | | | | Bits 04 to 15: 0 | Not used |

- After Change (m = D20000 + Unit number x 100)

| Offset | | | | Setting range | Setting name |
|-------------|-------------|-------------|-------------|-----------------------|--|
| Input No. 1 | Input No. 2 | Input No. 3 | Input No. 4 | | |
| m+30 | m+38 | m+46 | m+54 | Bits 00 to 03: 0 to 3 | Decimal point from right of instantaneous value conversion coefficient |
| | | | | Bits 04 to 07: 0 to 4 | Instantaneous value time unit 0: 1 s 1: 3 s 2: 10 s 3: 30 s 4: 60 s |
| | | | | Bits 08 to 15: 0 | Not used |

1-7-2 CS1W-PTS51/PTS52 and CJ1W-PTS51/PTS52

The specifications of the following I/O Units with the lot number XX84 or later (manufactured since August 2004) have been changed as shown in the table below.

| Model | Name | Main changes |
|------------------|--|---|
| CS1W-PTS51/PTS52 | Isolated-type Thermocouple Input Units | <ul style="list-style-type: none"> • Added setting for selecting the span adjustment resolution for the zero/span adjustment function. Before change: Resolution of 1/1,000 After change: Resolution of 1/1,000 or 1/10,000 selectable |
| CJ1W-PTS51/PTS52 | | |

CS1W-PTS51/PTS52

- Before Change (m = D20000 + Unit number x 100)

| DM address | | | | Data range | | Default value | Data name |
|-------------|-------------|-------------|-------------|------------|------------------|-----------------|-------------------|
| Input No. 1 | Input No. 2 | Input No. 3 | Input No. 4 | Decimal | Hexadecimal | | |
| | | | | | | | Span adjustment |
| m+4 | m+8 | m+12 | m+16 | 0 to 9999 | 0000 to 270F hex | 1000 (03E8 hex) | Set value x 0.001 |

• After Change (m = D20000 + Unit number × 100)

| DM address | | | | Data range | | Default value | Data name |
|-------------|-------------|-------------|-------------|------------|------------------|------------------|--|
| Input No. 1 | Input No. 2 | Input No. 3 | Input No. 4 | Decimal | Hexadecimal | | |
| | | | | | | | Span adjustment |
| m+4 | m+8 | m+12 | m+16 | 0 to 9999 | 0000 to 270F hex | 1000 (03E8 hex) | m+35 contains 0: Set value × 0.001 |
| | | | | 0 to 32000 | 0000 to 7D00 hex | 10000 (2710 hex) | m+35 contains 1: Set value × 0.0001 |
| | | | | | | | Span adjustment mode setting |
| m+35 | | | | 0, 1 | 0000, 0001 hex | 1 (See note.) | 0: 1/1,000 1: 1/10,000 |

Note Indicates the value after transferring the default values (set when 12345 is written to word m).

CJ1W-PTS51/PTS52

Settings are the same as for the CS1 models, except that the address m+35 becomes m+32.

1-7-3 CS1W-PTS55 and CS1W-PDC55

The specifications of the following Analog I/O Units with a lot number of 070315_XXXX or later (manufactured since March 15, 2007) have been changed as shown in the table below.

| Model | Name | Main changes |
|------------|---------------------------------------|---|
| CS1W-PTS55 | Isolated-type Thermocouple Input Unit | Added functionality for temperature data notation in units of 0.1°C or 0.1°F. (Only binary is supported for the data format.) |
| CJ1W-PDC55 | Isolated-type Thermocouple Input Unit | Added functionality for holding data during a sensor error. |

CS1W-PTS55

• Before Change (m = D20000 + Unit number × 100)

| Word | Bit | Default value | Description | Settings |
|------|-----|---------------|---|--|
| m+34 | 00 | 0 | Temperature unit setting | 0: °C 1: °F |
| | 04 | 0 | Data format | 0: Binary (Negative values are given as 2's complements.) 1: BCD |
| | 08 | 0 | Minus sign display format for BCD display | 0: "F" used to indicate the minus sign. 1: Leftmost bit used to indicate the minus sign. The setting is disabled if bits 04 to 07 are set to 0. |
| | 12 | 0 | Data direction at sensor error | 0: Goes to upper limit at sensor error. 1: Goes to lower limit at sensor error. |

• After Change (m = D20000 + Unit number × 100)

| Word | Bit | Default value | Description | Settings |
|------|-----|---------------|---|--|
| m+34 | 00 | 0 | Temperature unit setting | 0: °C 1: °F |
| | 01 | 0 | Data unit setting | 0: Follow the input type setting. 1: Use units of 0.1°C or 0.1°F as the temperature data format. (Only binary is supported.) |
| | 04 | 0 | Data format | 0: Binary (Negative values are given as 2's complements.) 1: BCD |
| | 08 | 0 | Minus sign display format for BCD display | 0: "F" used to indicate the minus sign. 1: Leftmost bit used to indicate the minus sign. The setting is disabled if bits 04 to 07 are set to 0. |
| | 12 | 0 | Data direction at sensor error | 0: Goes to upper limit at sensor error. 1: Goes to lower limit at sensor error. |

CS1W-PDC55

• Before Change (m = D20000 + Unit number × 100)

| Word | Bit | Default value | Description | Settings |
|------|-----|---------------|---|--|
| m+34 | 00 | 0 | Data format | 0: Binary (Negative values are given as 2's complements.) 1: BCD |
| | 08 | 0 | Minus sign display format for BCD display | 0: "F" used to indicate the minus sign. 1: Leftmost bit used to indicate the minus sign. The setting is disabled if bits 04 to 07 are set to 0. |
| | 12 | 0 | Data direction at sensor error | 0: Goes to upper limit at sensor error. 1: Goes to lower limit at sensor error. |

• After Change (m = D20000 + Unit number × 100)

| Word | Bit | Default value | Description | Settings |
|------|-----|---------------|---|--|
| m+34 | 00 | 0 | Data format | 0: Binary (Negative values are given as 2's complements.) 1: BCD |
| | 08 | 0 | Minus sign display format for BCD display | 0: "F" used to indicate the minus sign. 1: Leftmost bit used to indicate the minus sign. The setting is disabled if bits 04 to 07 are set to 0. |
| | 12 | 0 | Data direction at sensor error | 0: Goes to upper limit at sensor error. 1: Goes to lower limit at sensor error. |
| | 13 | 0 | Data held at sensor error | 0: Follow the setting of bit 12. 1: If there is a sensor error when the upper limit is exceeded, hold the data at the upper limit. If there is a sensor error when the lower limit is exceeded, hold the data at the lower limit. |

SECTION 2

Individual Unit Descriptions for CS Series

This section describes each of the CS-series Analog I/O Units in detail.

| | | |
|------|---|-----|
| 2-1 | CS1W-PTS01-V1 Isolated-type Thermocouple Input Unit | 68 |
| 2-2 | CS1W-PTS11 Isolated-type Thermocouple Input Unit | 80 |
| 2-3 | CS1W-PTS51 Isolated-type Thermocouple Input Unit | 97 |
| 2-4 | CS1W-PTS55 Isolated-type Thermocouple Input Unit | 109 |
| 2-5 | CS1W-PTS02 Isolated-type Resistance Thermometer Input Unit (Pt100 or JPt100) | 121 |
| 2-6 | CS1W-PTS03 Isolated-type Resistance Thermometer Input Unit (Ni508.4) | 132 |
| 2-7 | CS1W-PTS12 Isolated-type Resistance Thermometer Input Unit (Pt100, JPt100, Pt50, Ni508.4) | 142 |
| 2-8 | CS1W-PTS52 Isolated-type Resistance Thermometer Input Unit (Pt100, JPt100). | 157 |
| 2-9 | CS1W-PTS56 Isolated-type Resistance Thermometer Input Unit (Pt100, JPt100). | 167 |
| 2-10 | CS1W-PTW01 2-Wire Transmitter Input Unit | 177 |
| 2-11 | CS1W-PDC01 Isolated-type Direct Current Input Unit | 189 |
| 2-12 | CS1W-PDC11 Isolated-type Direct Current Input Unit | 200 |
| 2-13 | CS1W-PDC55 Isolated-type Direct Current Input Unit | 218 |
| 2-14 | CS1W-PTR01 Power Transducer Input Unit. | 229 |
| 2-15 | CS1W-PTR02 Analog Input Unit (100 mV) | 238 |
| 2-16 | CS1W-PPS01 Isolated-type Pulse Input Unit | 247 |
| 2-17 | CS1W-PMV01 Isolated-type Analog Output Unit | 258 |
| 2-18 | CS1W-PMV02 Isolated-type Analog Output Unit | 267 |

2-1 CS1W-PTS01-V1 Isolated-type Thermocouple Input Unit

Overview

The CS1W-PTS01-V1 Isolated-type Thermocouple Input Unit provides four direct thermocouple inputs, and sends the data to the CPU Unit each cycle. All inputs are isolated.

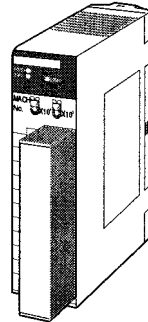

CS1W-PTS01-V1

System Configuration

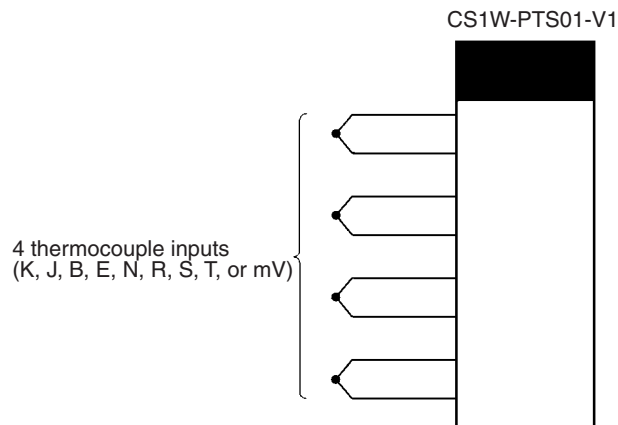

Features

- Up to four thermocouples can be directly connected to each Unit (with four separate settings for temperature sensors and input ranges).
- Isolation between inputs prevents sneak circuits from occurring between thermocouple inputs.
- This Unit is suitable for a wide range of temperature specifications. K, J, B, E, N, R, S, or T can be selected.
- Temperature sensor values are transmitted to the CPU Unit in four digits hexadecimal.
- Variable input range setting.
- Four values for each process value alarm input.
- ON-delay timer for process value alarm.
- Mean value processing.
- Rate-of-change calculation.
- Two values for each rate-of-change alarm input.
- Zero/span adjustment capability during operation.
- Disconnection detection.
- Maximum or minimum process value can be specified for when a disconnection is detected.

Model Information

| Unit classification | Model number | Inputs | Temperature sensor types |
|----------------------------|---------------|--------|---|
| CS-series Special I/O Unit | CS1W-PTS01-V1 | 4 | Thermocouple K, J, B, E, N, R, S, T, or mV. |

Block Diagram (Order of Processing)

The processing for the four inputs is as shown in the following diagram.

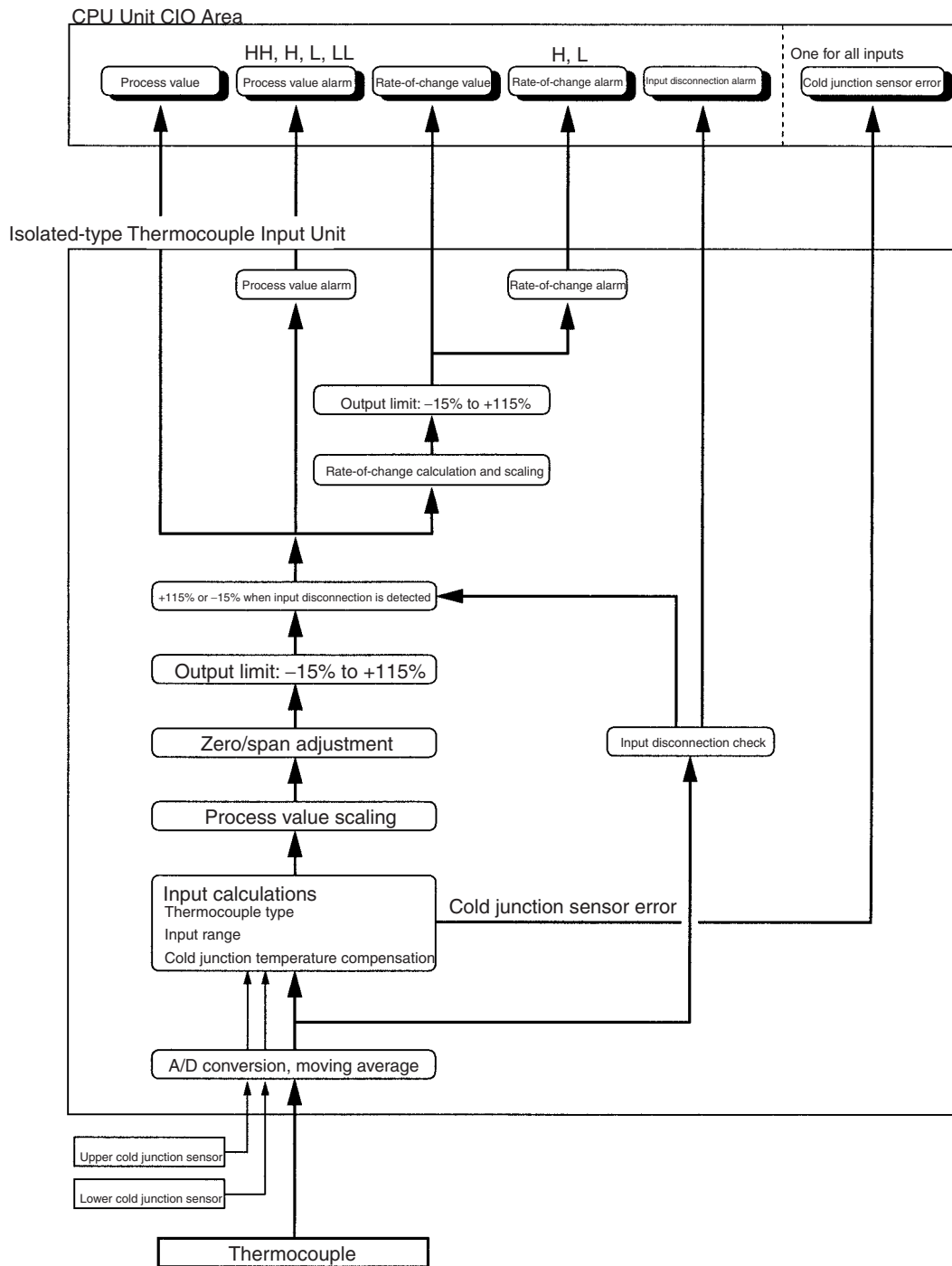

Specifications

| Item | | Specifications |
|---------------------------------------|--|---|
| Model number | | CS1W-PTS01-V1 |
| Applicable PLC | | CS Series |
| Unit classification | | CS-series Special I/O Unit |
| Mounting position | | CS-series CPU Rack or CS-series Expansion Rack (Cannot be mounted to C200H Expansion I/O Rack or SYSMAC BUS Remote I/O Slave Rack.) |
| Maximum number of Units | | 80 (within the allowable current consumption and power consumption range) |
| Unit numbers | | 00 to 95 (Cannot duplicate Special I/O Unit numbers.) |
| Areas for data exchange with CPU Unit | Special I/O Unit Area | 10 words/Unit Thermocouple Input Unit to CPU Unit: All process values, process value alarms (LL, L, H, HH), rate-of-change values, rate-of-change alarms (L, H), disconnection alarms, cold junction sensor errors |
| | DM Area words allocated to Special I/O Units | 100 words/Unit CPU Unit to Thermocouple Input Unit: Temperature sensor type, input range (user set), scaling of process value data to be stored in allocated words in CIO area, number of items for moving average, process value alarm setting (LL, L, H, HH), rate-of-change alarm setting (L, H), zero/span adjustment value, etc. |
| Number of temperature sensor inputs | | 4 |
| Temperature sensor types | | Thermocouple B, E, J, K, N, R, S, T or -80 to 80 mV. (Set separately for each of four inputs.) Note Sensor type, input range, and scaling to industrial units are separate for each of the 4 inputs. Note Sensor type, input range, and scaling to industrial units are set in the DM Area. |
| Input ranges | | The input range can be set within any of the measurable input ranges shown in Table 1 (below). Note Internally, inputs are processed in five ranges (refer to Table 2 below), so accuracy and resolution accord with these internal ranges. |
| Scaling in industrial units | | Example: Thermocouple: K; input range: 0 to 500°C; industrial unit scaling: 0 to 500°C. DM Area settings are as follows: Thermocouple: 3 (0003 hex) Input signal maximum: 5000 (1388 hex) Input signal minimum: 0 (0000 hex) Industrial unit maximum value stored: 500 (01F4 hex) Industrial unit minimum value stored: 0 (0000 hex) |
| Data storage in the CIO Area | | Data to be stored in the allocated words in the CIO area must be scaled (with the minimum and maximum values set). Data can be stored at 0% to 100%. |
| Accuracy (25°C) | | The value derived from carrying out the following processing in order of the actual process data in the input range is stored in four digits hexadecimal (binary values) in the allocated words in the CIO Area. 1) Mean value processing → 2) Scaling → 3) Zero/span adjustment → 4) Output limits ±0.1% (of internal range full span) As shown in the following equation, the accuracy depends on the ratio of the selected internal range (0 to 4) span to the set input range span. $\text{Accuracy} = \pm 0.1\% \times \frac{\text{Internal range span (electromotive force conversion)}}{\text{Set input range span (electromotive force conversion)}}$ |
| Temperature coefficient | | ±0.015% /°C, for any of internal range numbers 0 to 4. |
| Resolution | | 1/4,096 (of internal range full span) As shown in the following equation, the resolution depends on the ratio of the selected internal range (0 to 4) span to the set input range span. $\text{Resolution} = \frac{1}{4096} \times \frac{\text{Internal range span (electromotive force conversion)}}{\text{Set input range span (electromotive force conversion)}}$ |
| Cold junction compensation error | | ±1°C, at 20 ±10°C |
| Warmup time | | 45 min |
| Maximum signal input | | -80 to 80 mV |

| Item | | Specifications |
|--|--------------------------------------|--|
| Input impedance | | 20 kΩ min. |
| Input disconnection detection current | | 0.1 μA (typical) |
| Response time | | 1 s (travel time from input 0% to 90%, for step input) |
| Conversion period | | 150 ms/4 inputs |
| Maximum time to store data in CPU Unit | | Conversion period + one CPU Unit cycle |
| Disconnection detection | | Detects disconnections at each input and turns ON the Disconnection Detection Flag. Hardware detection time: Approx. 5 s The process value overrange direction for when a disconnection occurs can be specified. (High: 115% of set input range; low: -15% of set input range) |
| Function | Mean value processing (input filter) | Calculates the moving average for the specified number of process values (1 to 16), and stores that value in the CIO Area as the process value. |
| | Process value alarm | Process value 4-point alarm (HH, H, LL, L), alarm hysteresis, and ON-delay timer (0 to 60 s) are available. |
| | Rate-of-change calculation | Calculates the amount of change per comparison time interval (1 to 16 s). |
| | Rate-of-change alarm | Rate-of-change 2-point alarm (H, L), alarm hysteresis (shared with process value alarm), and ON-delay timer (0 to 60 s, shared with process value alarm) are available. |
| Isolation | | Between temperature inputs and between input terminals and PLC signals: Isolation by transformer |
| Insulation resistance | | 20 MΩ (at 500 V DC) between inputs |
| Dielectric strength | | Between inputs: 1,000 V AC, at 50/60 Hz, for 1 min, leakage current 10 mA max. |
| External connections | | Terminal block (detachable) |
| Unit number settings | | Set by rotary switches on front panel, from 0 to 95. |
| Indicators | | Three LED indicators on front panel (for normal operation, errors detected at the Thermocouple Input Unit, and errors related to the CPU Unit). |
| Front panel connector | | Sensor input connector terminal block (detachable) |
| Effect on CPU Unit cycle time | | 0.3 ms |
| Current consumption | | 5 V DC at 150 mA max., 26 V DC at 150 mA max. |
| Dimensions | | 35 × 130 × 126 mm (W × H × D) Note The height including the Backplane is 145 mm. |
| Weight | | 450 g max. |
| Standard accessories | | Two cold junction sensors (installed in terminal block) |

Sensor Types and Input Ranges

The temperature sensor (thermocouple) type and input range are set in the allocated words in the DM Area for every four inputs. The input range can be set anywhere within the measurable input ranges shown in Table 1.

Table 1: Measurable Input Ranges

| Sensor type | DM Area setting | Measurable input range (See note.) |
|-------------|-----------------|------------------------------------|
| B | 0 | 0 to 1,820°C |
| E | 1 | -270 to 1,000°C |
| J | 2 | -210 to 1,200°C |
| K | 3 | -270 to 1,372°C |
| N | 4 | -270 to 1,300°C |
| R | 5 | -50 to 1,768°C |
| S | 6 | -50 to 1,768°C |
| T | 7 | -270 to 400°C |
| mV | 8 | -80 to 80 mV |

Note Set the input range in the DM Area within this range.

Inputs are processed internally in five progressive ranges (numbers 0 to 4), as shown in the following table.

Table 2: Internal Ranges

| Internal range number | Thermocouple electromotive force | Internal range span |
|-----------------------|----------------------------------|---------------------|
| 0 | -80 to 80 mV | 160 mV |
| 1 | -40 to 40 mV | 80 mV |
| 2 | -20 to 20 mV | 40 mV |
| 3 | -10 to 10 mV | 20 mV |
| 4 | -5 to 5 mV | 10 mV |

Therefore, the accuracy and resolution are determined by the ratio of the selected internal range (0 to 4) span to the set input range span (electromotive force converted value). For the internal range, a larger number is selected when both the minimum and maximum values of the range fall within that next range.

For example, suppose that the thermocouple type is K and the set input range is 0 to 800°C. The electromotive force for K 0 to 800°C is 0 to 33.277 mV. Since both the minimum and maximum values fall within the limits for internal range No. 1 (-40 to 40 mV), that range will be selected.

The following table shows the set input ranges corresponding to the internal range numbers 0 to 4.

Table 3: Set Input Ranges Corresponding to Internal Ranges

| Sensor type | Measurable Input range | Internal range No. 0 | Internal range No. 1 | Internal range No. 2 | Internal range No. 3 | Internal range No. 4 |
|-------------|------------------------|----------------------|----------------------|----------------------|----------------------|----------------------|
| | | -80 to 80 mV | -40 to 40 mV | -20 to 20 mV | -10 to 10 mV | -5 to 5 mV |
| B | 0 to 1,820°C | Not used. | Not used. | 0 to 1,820°C | 0 to 1,496°C | 0 to 1,030°C |
| E | -270 to 1,000°C | -270 to 1,000°C | -270 to 537°C | -270 to 286°C | -270 to 153°C | -94 to 80°C |
| J | -210 to 1,200°C | -210 to 1,200°C | -210 to 713°C | -210 to 366°C | -210 to 186°C | -100 to 95°C |
| K | -270 to 1,372°C | -270 to 1,372°C | -270 to 967°C | -270 to 484°C | -270 to 246°C | -153 to 121°C |
| N | -270 to 1,300°C | -270 to 1,300°C | -270 to 1,097°C | -270 to 584°C | -270 to 318°C | -270 to 171°C |
| R | -50 to 1,768°C | Not used. | -50 to 1,769°C | -50 to 1,684°C | -50 to 961°C | -50 to 548°C |
| S | -50 to 1,768°C | Not used. | Not used. | -50 to 1,769°C | -50 to 1,035°C | -50 to 576°C |
| T | -270 to 400°C | Not used. | -270 to 400°C | -270 to 385°C | -270 to 213°C | -166 to 115°C |
| mV | -80 to 80 mV | -80 to 80 mV | -40 to 40 mV | -20 to 20 mV | -10 to 10 mV | -5 to 5 mV |

Note With Thermocouple Input Units, process values can be scaled in industrial units for the set input range. It is possible to set the process value scaling higher than the resolution, but it will cause the values to be unstable.

DM Area Allocations

$$m = D20000 + \text{unit number} \times 100 \text{ (unit number: 0 to 95)}$$

| DM Area address | | | | Data range | | Default | Data contents |
|--|-------------|-------------|-------------|-----------------|------------------------------------|------------------|---|
| Input No. 1 | Input No. 2 | Input No. 3 | Input No. 4 | Decimal | Hexadecimal | | |
| m | | | | 12345, 0 | 3039, 0000 hex | 0000 hex | Default block read command Specifies the direction of data transfer when the PLC is turned ON or the Unit is restarted for DM words m+2 to m+93. <ul style="list-style-type: none"> 12345 (3039 hex): The data in words m+2 to m+93 is transferred from the Thermocouple Input Unit to the CPU Unit. When the transfer is completed, the value will become 0000 hex. Other than 12345 (such as 0000 hex): The data in the allocated words of DM Area is transferred from the CPU Unit to the Thermocouple Input Unit. |
| Setting Group 1 (continuously refreshed area): Parameters that are continuously refreshed during PLC operation (regardless of the CPU Unit's operation mode) | | | | | | | |
| | | | | | | | Process value alarm settings |
| m + 2 | m + 10 | m + 18 | m + 26 | -32768 to 32767 | 8000 to FFFF hex, 0000 to 7FFF hex | 4200 (1068 hex) | Process value HH (high high limit) alarm setting (Set at process value scaling value.) |
| m + 3 | m + 11 | m + 19 | m + 27 | -32768 to 32767 | 8000 to FFFF hex, 0000 to 7FFF hex | 4000 (0FA0 hex) | Process value H (high limit) alarm setting (Set at process value scaling value.) |
| m + 4 | m + 12 | m + 20 | m + 28 | -32768 to 32767 | 8000 to FFFF hex, 0000 to 7FFF hex | 0 (0000 hex) | Process value L (low limit) alarm setting (Set at process value scaling value.) |
| m + 5 | m + 13 | m + 21 | m + 29 | -32768 to 32767 | 8000 to FFFF hex, 0000 to 7FFF hex | -200 (FF38 hex) | Process value LL (low low limit) alarm setting (Set at process value scaling value.) |
| | | | | | | | Rate-of-change value alarm settings |
| m + 6 | m + 14 | m + 22 | m + 30 | -32768 to 32767 | 8000 to FFFF hex, 0000 to 7FFF hex | 4000 (0FA0 hex) | Rate-of-change value H (high limit) alarm setting (Set at rate-of-change scaling value.) |
| m + 7 | m + 15 | m + 23 | m + 31 | -32768 to 32767 | 8000 to FFFF hex, 0000 to 7FFF hex | 0 (0000 hex) | Rate-of-change value L (low limit) alarm setting (Set at rate-of-change scaling value.) |
| | | | | | | | Zero/span adjustment |
| m + 8 | m + 16 | m + 24 | m + 32 | 0 to 32000 | 0000 to 7D00 hex | 10000 (2710 hex) | Gain for span adjustment (set value x 0.0001) |
| m + 9 | m + 17 | m + 25 | m + 33 | -32000 to 32000 | 8300 to FFFF hex, 0000 to 7D00 hex | 0 (0000 hex) | Zero adjustment value (Set at process value scaling value.) |
| Setting Group 2 (initial settings area): Parameters that are transferred one time from the CPU Unit to the Thermocouple Input Unit if word m contains other than 12345 when the PLC is turned ON or the Thermocouple Input Unit is restarted. | | | | | | | |
| m + 34 | m + 49 | m + 64 | m + 79 | 0 to 8 | 0000 to 0008 hex | 3 (0003 hex) | Sensor type 0: B, 1: E, 2: J, 3: K, 4: N, 5: R, 6: S, 7: T, 8: mV |
| | | | | | | | Process value input range settings |
| m + 35 | m + 50 | m + 65 | m + 80 | -32000 to 32000 | 8300 to FFFF hex, 0000 to 7D00 hex | 4000 (0FA0 hex) | Maximum input signal value (set value x 0.1°C/°F or mV) |
| m + 36 | m + 51 | m + 66 | m + 81 | -32000 to 32000 | 8300 to FFFF hex, 0000 to 7D00 hex | 0 (0000 hex) | Minimum input signal value (set value x 0.1°C/°F or mV) |
| m + 37 | m + 52 | m + 67 | m + 82 | 0, 1 | 0000, 0001 hex | 0 (0000 hex) | Unit 0: °C, 1: °F |
| m + 38 | m + 53 | m + 68 | m + 83 | 0, 1 | 0000, 0001 hex | 0 (0000 hex) | Process value overrange direction at time of input disconnection 0: High; 1: Low |
| | | | | | | | Process value scaling |
| m + 39 | m + 54 | m + 69 | m + 84 | -32000 to 32000 | 8300 to FFFF hex, 0000 to 7D00 hex | 4000 (0FA0 hex) | Value stored for maximum value in range (span) |
| m + 40 | m + 55 | m + 70 | m + 85 | -32000 to 32000 | 8300 to FFFF hex, 0000 to 7D00 hex | 0 (0000 hex) | Value stored for minimum value in range (zero) |

| DM Area address | | | | Data range | | Default | Data contents | |
|--------------------------|-------------|-------------|-------------|-----------------|---------------------------------------|---------------------|---|--|
| Input No. 1 | Input No. 2 | Input No. 3 | Input No. 4 | Decimal | Hexadecimal | | | |
| | | | | | | | Alarm supplementary functions | |
| m + 41 | m + 56 | m + 71 | m + 86 | 0 to 32000 | 0000 to 7D00 hex | 40 (0028 hex) | Alarm hysteresis (Set at process value scaling value. Shared with process value alarm and rate-of-change alarm.) | |
| m + 42 | m + 57 | m + 72 | m + 87 | 0 to 60 | 0000 to 003C hex | 0 (0000 hex) | Alarm ON-delay time (Unit: s) (Shared with process value alarm and rate-of-change alarm.) | |
| | | | | | | | Rate-of-change function | |
| m + 43 | m + 58 | m + 73 | m + 88 | -32000 to 32000 | 8300 to FFFF hex, 0000 to 7D00 hex | 4000 (0FA0 hex) | Rate-of-change range setting | Maximum rate-of-change value (Process value industrial unit; comparison time interval) |
| m + 44 | m + 59 | m + 74 | m + 89 | -32000 to 32000 | 8300 to FFFF hex, 0000 to 7D00 hex | -4000 (F060 hex) | | Minimum rate-of-change value (Process value industrial unit; comparison time interval) |
| m + 45 | m + 60 | m + 75 | m + 90 | 1 to 16 | 0001 to 0010 hex | 1 (0001 hex) | Rate-of-change comparison time interval (Unit: s) | |
| m + 46 | m + 61 | m + 76 | m + 91 | -32000 to 32000 | 8300 to FFFF hex, 0000 to 7D00 hex | 4000 (0FA0 hex) | Rate-of-change value scaling | Value stored for maximum value in range |
| m + 47 | m + 62 | m + 77 | m + 92 | -32000 to 32000 | 8300 to FFFF hex, 0000 to 7D00 hex | 0 (0000 hex) | | Value stored for minimum value in range |
| | | | | | | | Mean value processing function | |
| m + 48 | m + 63 | m + 78 | m + 93 | 1 to 16 | 0001 to 0010 hex | 4 (0004 hex) | Number of process values for calculating moving average for mean value processing | |
| Storage parameter | | | | | | | | |
| m + 94 | m + 95 | m + 96 | m + 97 | 0 to 93 | 0000 to 005D hex | 0 (0000 hex) | Address of Data Range Error (See note.) | |

Note The ERC indicator on the Unit's front panel will light if an out-of-range setting is made in either Setting Group 1 or 2. The offset from word m to the first word containing the out-of-range error will be stored as the Address of Data Range Error in the DM Area in four digits hexadecimal. For more information, refer to 1-6 Error Processing.

CIO Area Allocations

n = 2000 + unit number × 10 (unit number: 0 to 95)

| Direction | Word | Bit | Name | | Data range | Contents |
|-------------------------------------|------|-----|-------------|--|------------|------------------------------|
| Thermocouple Input Unit to CPU Unit | n | 00 | Input No. 1 | Process value LL (low low limit) alarm | 0, 1 | 0: Process value > Set value |
| | | 01 | | Process value L (low limit) alarm | 0, 1 | 1: Process value ≤ Set value |
| | | 02 | | Process value H (high limit) alarm | 0, 1 | 0: Process value < Set value |
| | | 03 | | Process value HH (high high limit) alarm | 0, 1 | 1: Process value ≥ Set value |
| | | 04 | Input No. 2 | Process value LL (low low limit) alarm | 0, 1 | Same as for input No. 1. |
| | | 05 | | Process value L (low limit) alarm | | |
| | | 06 | | Process value H (high limit) alarm | | |
| | | 07 | | Process value HH (high high limit) alarm | | |
| | | 08 | Input No. 3 | Process value LL (low low limit) alarm | | |
| | | 09 | | Process value L (low limit) alarm | | |
| | | 10 | | Process value H (high limit) alarm | | |
| | | 11 | | Process value HH (high high limit) alarm | | |
| | | 12 | Input No. 4 | Process value LL (low low limit) alarm | | |
| | | 13 | | Process value L (low limit) alarm | | |
| | | 14 | | Process value H (high limit) alarm | | |
| | | 15 | | Process value HH (high high limit) alarm | | |

| Direction | Word | Bit | Name | | Data range | Contents | |
|-------------------------------------|-------|----------------------------|----------------------------------|---|--|--|--|
| Thermocouple Input Unit to CPU Unit | n + 1 | 00 to 15 | Input No. 1 process value | | -32768 to 32767 (8000 to FFFF hex, 0000 to 7FFF hex) | The present process value is stored according to the scaling set in the allocated words of the DM Area. | |
| | n + 2 | 00 to 15 | Input No. 2 process value | | | | |
| | n + 3 | 00 to 15 | Input No. 3 process value | | | | |
| | n + 4 | 00 to 15 | Input No. 4 process value | | | | |
| | n + 5 | 00 to 15 | Input No. 1 rate-of-change value | | -32768 to 32767 (8000 to FFFF hex, 0000 to 7FFF hex) | The process value rate of change is stored according to the scaling set in the allocated words of the DM Area. | |
| | n + 6 | 00 to 15 | Input No. 2 rate-of-change value | | | | |
| | n + 7 | 00 to 15 | Input No. 3 rate-of-change value | | | | |
| | n + 8 | 00 to 15 | Input No. 4 rate-of-change value | | | | |
| | n + 9 | 00 | | Input No. 1 | Rate-of-change value L (low limit) alarm | 0, 1 | 0: Rate-of-change value > Set value 1: Rate-of-change value ≤ Set value |
| | | | | | Rate-of-change value H (high limit) alarm | | 0, 1 |
| | | 02 | | Input No. 2 | Rate-of-change value L (low limit) alarm | 0, 1 | Same as for input No. 1. |
| | | | | | Rate-of-change value H (high limit) alarm | | |
| 04 | | | Input No. 3 | Rate-of-change value L (low limit) alarm | 0, 1 | | |
| | | | | Rate-of-change value H (high limit) alarm | | | |
| 06 | | | Input No. 4 | Rate-of-change value L (low limit) alarm | 0, 1 | | |
| | | | | Rate-of-change value H (high limit) alarm | | | |
| 08 | | | Input No. 1 input disconnection | | 0, 1 | 0: Normal 1: Disconnection | |
| 09 | | | Input No. 2 input disconnection | | | Same as for input No. 1. | |
| 10 | | | Input No. 3 input disconnection | | | Same as for input No. 1. | |
| 11 | | | Input No. 4 input disconnection | | | Same as for input No. 1. | |
| 12 | | Cold junction sensor error | | 0, 1 | | 0: Normal 1: Error | |

Terminal Connection Diagram

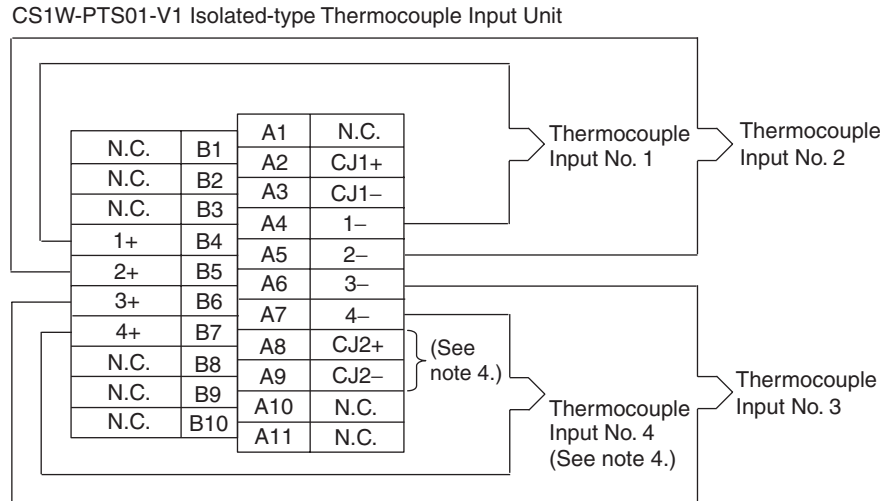

- Note**
1. Cold junction sensors are installed between A2 and A3, and between A8 and A9 when the product is shipped. Do not remove them when using the Unit. If they are removed, temperatures cannot be measured correctly because there will be no compensation.
 2. Use the same cold junction sensors that come with the Unit, and leave them just as they are. They are provided specifically for this Unit and its circuitry, and temperatures cannot be measured correctly if they are switched around or if another Unit's sensors are used in their place.
 3. For unused input terminals, short-circuit the positive and negative sides (e.g., terminals A4 and B4 for input No. 1) of the thermocouple inputs with the lead wire.
 4. When connecting input No. 4, remove the cold junction sensor between CJ2+ and CJ2-, and then reconnect it after the input is connected. Attempting to connect the input without removing the cold junction sensor may result in damage to the sensor.

Terminal Block Diagram

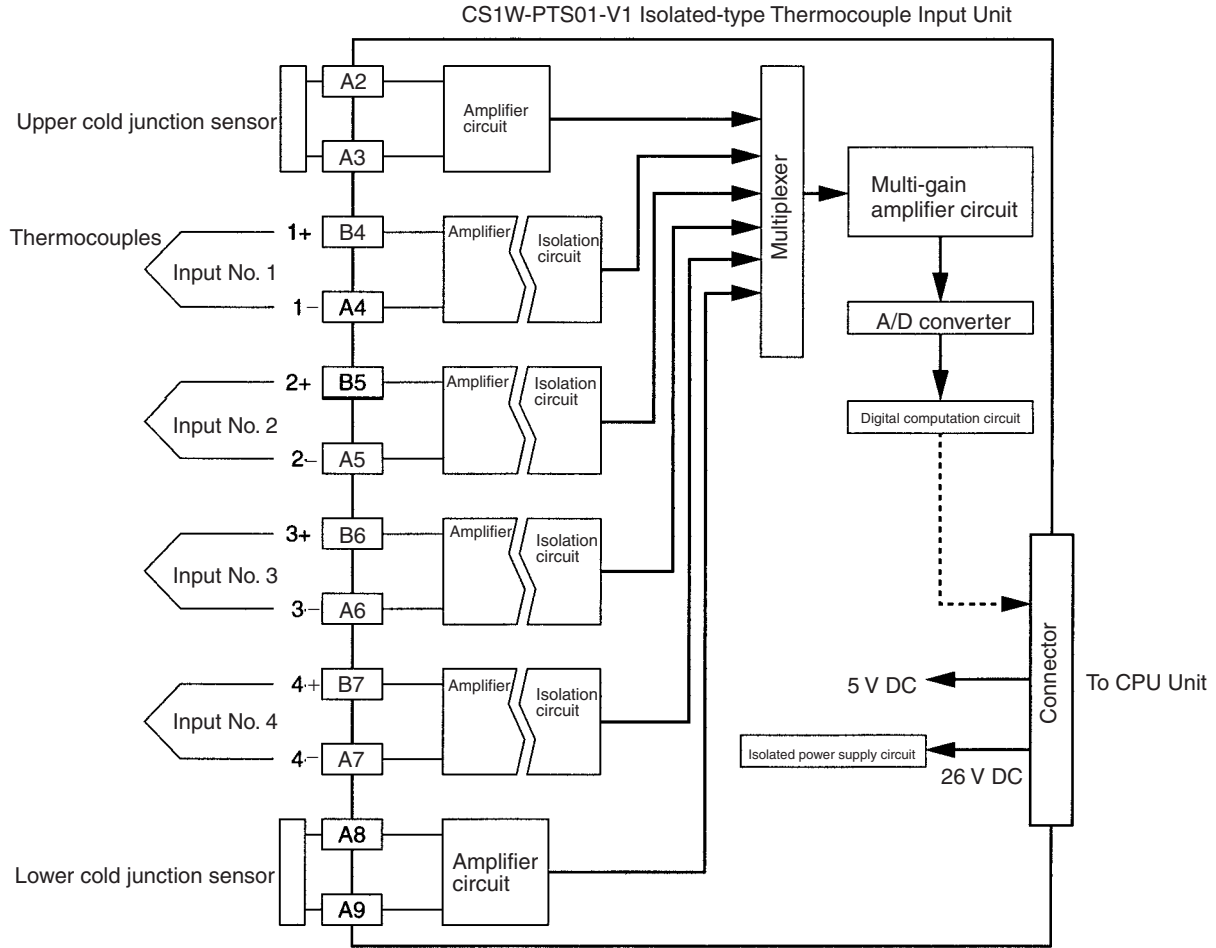

Error Processing

Conversion Data Does Not Change.

| Probable cause | Remedy |
|--|---|
| The gain for span adjustment is set to 0. | Set the gain for span adjustment to a value other than 0. |
| The minimum and maximum values for process value scaling are either the same or are set extremely low. | Set the minimum and maximum values correctly. |
| The sensor type, input range, or process value scaling is not set correctly. | Check and correct the settings. |
| An input device is malfunctioning, input wiring is faulty, or wiring is disconnected. | Check whether the input voltage has changed. Check for faulty or disconnected wiring. Check whether a wiring disconnection has been detected in the I/O Area. |

Values are Not Converted as Intended.

| Probable cause | Remedy |
|--|--|
| The sensor type, input range, or process value scaling is not set correctly. | Check and correct the settings. |
| The zero/span adjustment data is incorrect. | Check and correct the zero/span adjustment settings. |
| Cold junction compensation is not operating. | Check the Cold Junction Sensor Error Flag. |

| Probable cause | Remedy |
|---|---|
| No compensation lead wire is being used, or another type of compensation lead wire is being used. | Use the correct compensation lead wire for thermocouples. |
| The input wiring is faulty. (The thermocouple or compensation lead wire polarity is wrong.) | Correct the input wiring. |

Converted Values are Unstable.

| Probable cause | Remedy |
|--|---|
| Input signals are being affected by external noise. | Change the connection paths of the input signal lines. (Separate them from sources of noise or use shielded cable.) |
| | Insert 0.01- μ F to 0.1- μ F ceramic capacitors between the positive and negative input terminals. |
| | Increase the number of values for calculating the moving average in mean value processing. |
| The process value scaling value is greater than the Unit's resolution. | Reduce the process value scaling value. |
| The input signal range setting is too small. | Match the input signal range to the internal ranges. |

2-2 CS1W-PTS11 Isolated-type Thermocouple Input Unit

Overview

The CS1W-PTS11 Isolated-type Thermocouple Input Unit provides four direct thermocouple inputs, and sends the data to the CPU Unit each cycle. All inputs are isolated.

CS1W-PTS11

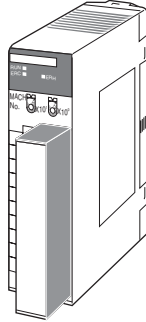

System Configuration

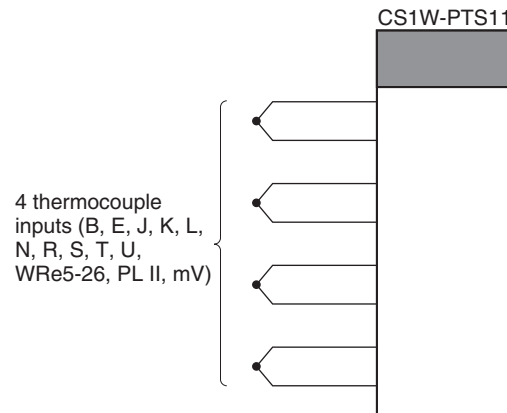

Features

- Up to four thermocouples can be connected for each Unit (with four separate settings for temperature sensors and input ranges).
- There is isolation between channels, so unwanted circuit paths between thermocouple inputs can be prevented.
- A variety of temperature specifications are supported. Any of the following can be selected for thermocouple input: B, E, J, K, L, N, R, S, T, U, WRe5-26, PL II, mV.
- Resolution of 1/64,000 for all temperature specifications.
- High-speed conversion, at 20 ms/4 inputs and 10 ms/2 inputs.
- Temperature sensor values are transmitted to the CPU Unit in four digits hexadecimal.
- Variable input range setting.
- Four values for each process value alarm input.
- ON-delay timer for process value alarm.
- Mean value processing.
- Rate-of-change calculation.
- Two values for each rate-of-change alarm input.
- Zero/span adjustment capability during operation.
- Disconnection detection.

- Maximum or minimum process value can be specified for when a disconnection is detected.
- Adjustment period control.
- Peak and bottom detection.
- Top and valley detection.

Model Information

| Unit classification | Model number | Inputs | Temperature sensor types |
|----------------------------------|---------------------|---------------|--|
| CS-series Special I/O Unit | CS1W-PTS11 | 4 | B, E, J, K, L, N, R, S, T, U, WRe5-26, PL II, mV |

Block Diagram (Order of Processing)

The processing for the inputs is as shown in the following diagram.

CPU Unit

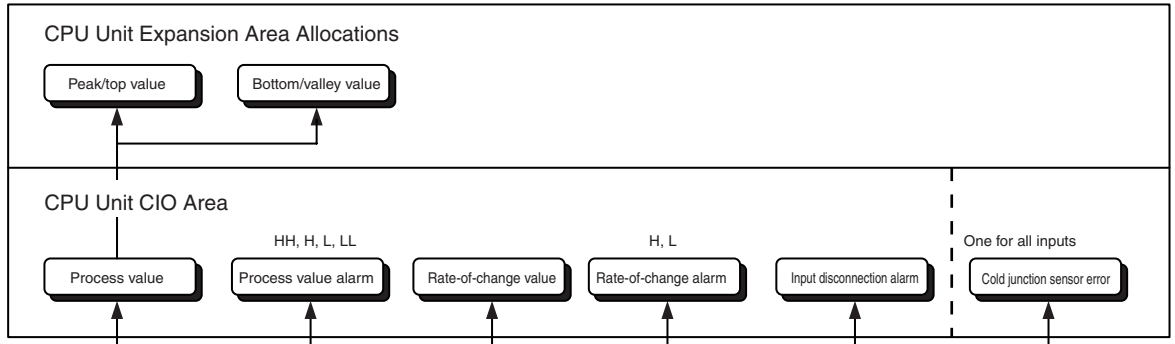

Isolated-type Thermocouple Input Unit

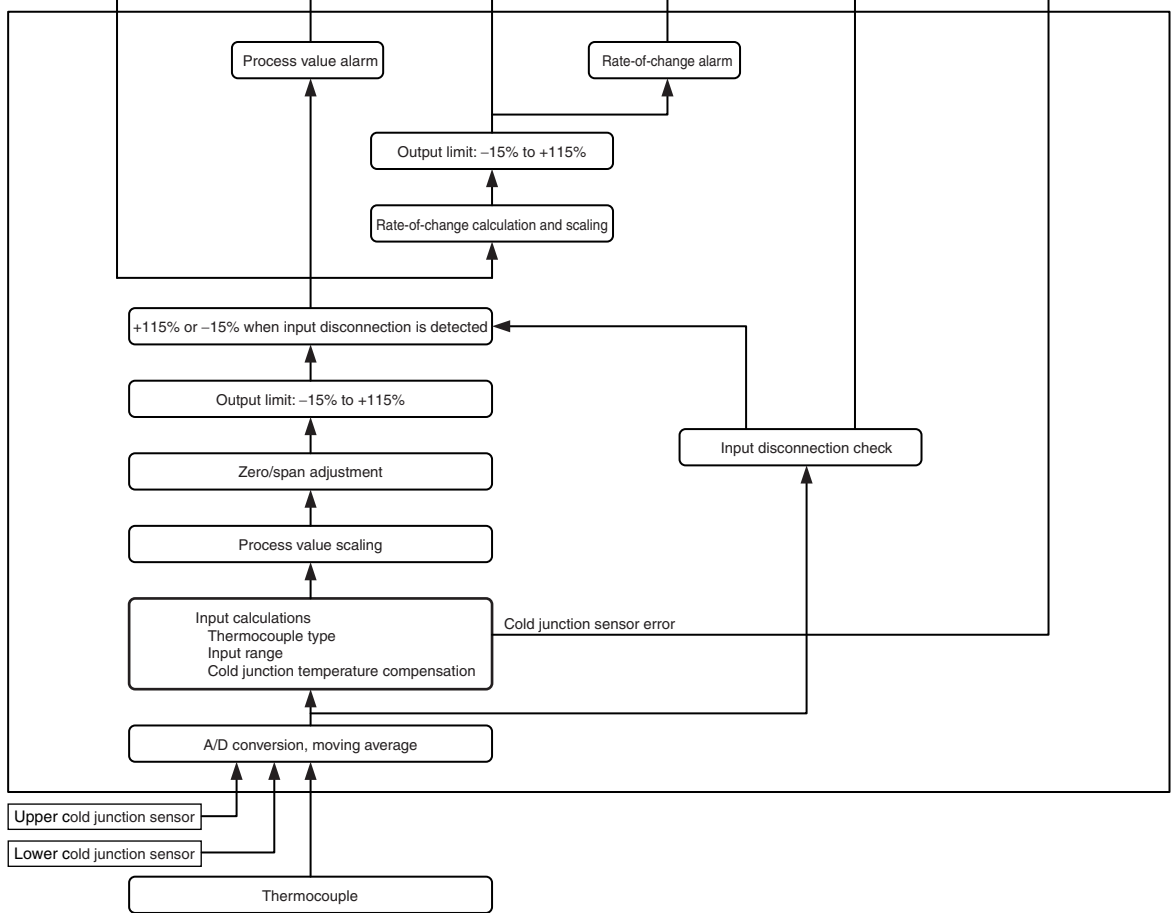

Specifications

| Item | | Specifications |
|---------------------------------------|--|---|
| Model | | CS1W-PTS11 |
| Applicable PLC | | CS Series |
| Unit classification | | CS-series Special I/O Unit |
| Mounting position | | CS-series CPU Rack or CS-series Expansion Rack (Cannot be mounted to C200H Expansion I/O Rack or SYSMAC BUS Remote I/O Slave Rack.) |
| Maximum number of Units | | 80 (within the allowable current consumption and power consumption range) |
| Unit numbers | | 00 to 95 (Cannot duplicate Special I/O Unit numbers.) |
| Areas for data exchange with CPU Unit | Special I/O Unit Area | 10 words/Unit Thermocouple Input Unit to CPU Unit: All process values, process value alarms (LL, L, H, HH), rate-of-change values, rate-of-change alarms (L, H), disconnection alarms, cold junction sensor errors |
| | DM Area words allocated to Special I/O Units | 100 words/Unit CPU Unit to Thermocouple Input Unit: Temperature sensor type, input range (user set), scaling of process value data to be stored in allocated words in CIO area, rate-of-change input range, scaling of rate-of-change data, number of items for moving average, process value alarm setting (LL, L, H, HH), rate-of-change alarm setting (L, H), zero/span adjustment value, etc. |
| | Expansion Control/Monitor Area | 35 words/Unit CPU Unit to Thermocouple Input Unit: Designations and flags for beginning or resetting the hold function selection, adjustment period control, etc. Thermocouple Input Unit to CPU Unit: Adjustment period notices (with each input), peak and bottom values, top and valley values |
| | Expansion Setting Area | 46 words/Unit CPU Unit to Thermocouple Input Unit: Expansion Control/Monitor Area settings, adjustment period control, peak and bottom detection, top and valley detection |
| Number of temperature sensor inputs | | 4 |
| Temperature sensor types | | The sensor type, input range, and scaling can be set individually for each of 4 inputs, which are each selectable from B, E, J, K, L, N, R, S, T, U, WRe5-26, PL II, and mV. |
| Scaling | | Data to be stored in the allocated words in the CIO area must be scaled (individually for each of the 4 inputs, with the minimum and maximum values set). Data can be stored at 0% to 100%. |
| Data storage in the CIO Area | | The value derived from carrying out the following processing in order of the actual process data in the input range is stored in four digits hexadecimal (binary values) in the allocated words in the CIO Area. 1) Mean value processing → 2) Scaling → 3) Zero/span adjustment → 4) Output limits |
| Accuracy (25°C) | | ±0.05% (Depends on the Sensor used and the measured temperature. Refer to <i>Accuracy by Sensor Type and Measured Temperature Range</i> on page 85 for details.) |
| Temperature coefficient | | ±0.01% /°C (For full scale of electromotive force. See note.) |
| Resolution | | 1/64,000 |
| Cold junction compensation error | | ±1°C, at 20°C±10°C |
| Warmup time | | 45 min |
| Maximum signal input | | ±120 mV |
| Input impedance | | 20 kΩ min. |
| Input disconnection detection current | | 0.1 μA (typical) |
| Response time | | 100 ms (travel time from input 0% to 90%, for ±100 mV step input and with moving average for 4 samples) |
| Conversion period | | 20 ms/4 inputs, 10 ms/2 inputs. Can be switched in DM Area words allocated to the Unit as a Special I/O Unit. |

| Item | | Specifications |
|---|--------------------------------------|---|
| Maximum time to store data in CPU Unit | | Conversion period + one CPU Unit cycle |
| Disconnection detection | | Detects disconnections at each input and turns ON the Disconnection Detection Flag. Hardware detection time: Approx. 0.5 s max. The process value overrange direction for when a disconnection occurs can be specified. (High: 115% of set input range; low: -15% of set input range) |
| Function | Mean value processing (input filter) | Calculates the moving average for the specified number of process values (1 to 128), and stores that value in the CIO Area as the process value. |
| | Process value alarm | Process value 4-point alarm (HH, H, LL, L), alarm hysteresis, and ON-delay timer (0 to 60 s) are available. |
| | Rate-of-change calculation | Calculates the amount of change per comparison time interval (1 to 16 s). |
| | Rate-of-change alarm | Rate-of-change 2-point alarm (H, L), alarm hysteresis (shared with process value alarm), and ON-delay timer (0 to 60 s, shared with process value alarm) are available. |
| | Adjustment period control | When zero/span adjustment is executed, the date is internally recorded at the Unit. When the preset zero/span adjustment period and number of days notice have elapsed, this function turns ON a warning flag to give notice that it is time for readjustment. |
| | Peak and bottom detection | This function detects the maximum (peak) and minimum (bottom) analog input values, from when the Hold Start Bit (output) allocated to the Expansion Control/Monitor Area turns ON until it turns OFF, and stores them in the Expansion Control/Monitor Area. |
| | Top and valley detection | This function detects the top and valley values for analog inputs, from when the Hold Start Bit (output) allocated to the Expansion Control/Monitor Area turns ON until it turns OFF, and stores them in the Expansion Control/Monitor Area. |
| Isolation | | Between inputs and PLC signals, and between inputs: Isolation by transformer for power supply, and by photocoupler for signals. |
| Insulation resistance | | 20 MΩ (at 500 V DC) between inputs |
| Dielectric strength | | Between inputs: 1,000 V AC, at 50/60 Hz, for 1 min, leakage current 10 mA max. |
| External connections | | Terminal block (detachable) |
| Unit number settings | | Set by rotary switches on front panel, from 0 to 95. |
| Indicators | | Three LED indicators on front panel (for normal operation, errors detected at the Thermocouple Input Unit, and errors related to the CPU Unit). |
| Front panel connector | | Sensor input connector terminal block (detachable) |
| Effect on CPU Unit cycle time | | 0.3 ms |
| Current consumption (supplied from Power Supply Unit) | | 5 V DC at 120 mA max., 26 V DC at 80 mA max. |
| Dimensions | | 35 × 130 × 126 mm (W × H × D) Note The height including the Backplane is 145 mm. |
| Weight | | 450 g max. |
| Standard accessories | | Two cold junction sensors (mounted to terminal block) |

Note The method for calculating the error in temperature measurements, including the temperature coefficient, is given below. The “full scale of electromotive force” is the difference between the high limit and low limit converted to electromotive force for each thermocouple.

Example

Ambient temperature: 30 °C
 Temperature Sensor: K thermocouple (−270 to 1,372 °C)
 Measured temperature: 500 °C

From electromotive force table

−270 °C: −6.458 mV
 1,372 °C: 54.86 mV
 Full scale: 61.344

Electromotive conversion of temperature coefficient:

$$61.344 \text{ mV} \times \pm 0.01\%/^{\circ}\text{C} = \pm 6.13 \text{ } \mu\text{V}/^{\circ}\text{C}$$

Error in electromotive force at 30°C:

$$\pm 6.13 \text{ } \mu\text{V}/^{\circ}\text{C} \times (30^{\circ}\text{C} - 25^{\circ}\text{C}) = 30.65 \text{ } \mu\text{V}/^{\circ}\text{C}$$

Temperature difference between measurement point and terminals on Unit (ambient temperature) (based on ambient temperature of 30 °C and Measured temperature of 500 °C):

$$470 \text{ }^{\circ}\text{C}$$

Electromotive force per °C at a measured temperature of 470 °C (from the electromotive force tables for a K thermocouple):

$$43 \text{ } \mu\text{V}/^{\circ}\text{C}$$

$$\text{Error in temperature coefficient: } \pm 30.65 \text{ } \mu\text{V} \div 43 \text{ } \mu\text{V}/^{\circ}\text{C} = \pm 0.7^{\circ}\text{C}$$

$$\text{Error in measured temperature} = \text{Accuracy} \pm \text{Error from temperature coefficient} + \text{Error in cold junction compensation} = \pm 0.8^{\circ}\text{C} + \pm 0.7^{\circ}\text{C} + \pm 1.0^{\circ}\text{C} = \pm 2.5^{\circ}\text{C}$$

Sensor Type and Input Range

The Temperature Sensor type and input range are set in the allocated words in the DM Area for every four inputs. The input range can be set anywhere within the measurable input ranges shown in the following table. Accuracy and resolution, however, are not determined from the set input range, but rather from the measurable input range shown in the following table. Therefore, accuracy and resolution do not change even when a narrow input range is set.

| Sensor type | DM Area setting | Measurable input range |
|-------------|-----------------|------------------------|
| B | 0 | 0 to 1,820°C |
| E | 1 | −270 to 1,000°C |
| J | 2 | −210 to 1,200°C |
| K | 3 | −270 to 1,372°C |
| N | 4 | −270 to 1,300°C |
| R | 5 | −50 to 1,768°C |
| S | 6 | −50 to 1,768°C |
| T | 7 | −270 to 400°C |
| mV | 8 | −100 to 100 mV |
| L | 9 | −200 to 900°C |
| U | 10 | −200 to 600°C |
| WRe5-26 | 11 | 0 to 2,300°C |
| PLII | 12 | 0 to 1,300°C |

Accuracy by Sensor Type and Measured Temperature Range

| Sensor type | Temperature range | Standard accuracy | Details |
|-------------|-------------------|-------------------|---|
| B | 0 to 1,820°C | ±1.8°C (±0.1%) | 400 to 800°C: ±3°C Less than 400°C: Accuracy is not specified. |
| E | −270 to 1,000°C | ±0.6°C (±0.05%) | −250 to 200°C: ±1.2°C Less than −250°C: Accuracy is not specified. |
| J | −210 to 1,200°C | ±0.7°C (±0.05%) | |
| K | −270 to 1,372°C | ±0.8°C (±0.05%) | −250 to 200°C: ±2°C Less than −250°C: Accuracy is not specified. |

| Sensor type | Temperature range | Standard accuracy | Details |
|-------------|-------------------|-------------------|---|
| N | -270 to 1,300°C | ±0.8°C (±0.05%) | -200 to 150°C: ±1.6°C Less than -200°C: Accuracy is not specified. |
| R | -50 to 1,769°C | ±1.8°C (±0.1%) | 0 to 100°C: ±2.5°C Less than 0°C: Accuracy is not specified. |
| S | -50 to 1,769°C | ±1.8°C (±0.1%) | 0 to 100°C: ±2.5°C Less than 0°C: 3.2°C |
| T | -270 to 400°C | ±0.35°C (±0.05%) | -180 to 0°C: ±0.7°C -200 to -180°C: ±1.3°C Less than -200°C: Accuracy is not specified. |
| L | -200 to 900°C | ±0.5°C (±0.05%) | |
| U | -200 to 600°C | ±0.4°C (±0.05%) | -100 to 0°C: ±0.5°C Less than -100°C: ±0.7°C |
| WRe5-26 | 0 to 2,315°C | ±1.2°C (±0.05%) | More than 2,200°C: ±1.4°C |
| PLII | 0 to 1,395°C | ±0.7°C (±0.05%) | |

DM Area Allocations

First word: m = D20000 + unit number × 100 (unit number: 0 to 95)

| DM Area address | | | | Data range | | Default | Data contents |
|---|-------------|-------------|-------------|--|------------------------------------|------------------|---|
| Input No. 1 | Input No. 2 | Input No. 3 | Input No. 4 | Decimal | Hexadecimal | | |
| m | | | | 12345, 0 | 3039, 0000 hex | 0000 hex | Default block read command Specifies the direction of data transfer when the PLC is turned ON or the Unit is restarted for DM words m+1 to m+93. <ul style="list-style-type: none"> • 12345 (3039 hex): The data in words m+1 to m+93 is transferred from the Thermocouple Input Unit to the CPU Unit. When the transfer is completed, the value will become 0000 hex. • Other than 12345 (3039 hex) (such as 0000 hex): The data in the allocated words of DM Area is transferred from the CPU Unit to the Thermocouple Input Unit. |
| | | | | Number of inputs setting | | | |
| m + 1 | | | | 0, 1 | 0000, 0001 hex | 0 (0000 hex) | 0: 4 inputs, 1: 2 inputs |
| Setting Group 1 (continuously refreshed area): Parameters that are continuously refreshed during PLC operation (regardless of the CPU Unit's operation mode) | | | | | | | |
| | | | | Process value alarm settings | | | |
| m + 2 | m + 10 | m + 18 | m + 26 | -32768 to 32767 | 8000 to FFFF hex, 0000 to 7FFF hex | 4200 (1068 hex) | Process value HH (high high limit) alarm setting (Set at process value scaling value.) |
| m + 3 | m + 11 | m + 19 | m + 27 | -32768 to 32767 | 8000 to FFFF hex, 0000 to 7FFF hex | 4000 (0FA0 hex) | Process value H (high limit) alarm setting (Set at process value scaling value.) |
| m + 4 | m + 12 | m + 20 | m + 28 | -32768 to 32767 | 8000 to FFFF hex, 0000 to 7FFF hex | 0 (0000 hex) | Process value L (low limit) alarm setting (Set at process value scaling value.) |
| m + 5 | m + 13 | m + 21 | m + 29 | -32768 to 32767 | 8000 to FFFF hex, 0000 to 7FFF hex | -200 (FF38 hex) | Process value LL (low low limit) alarm setting (Set at process value scaling value.) |
| | | | | Rate-of-change value alarm settings | | | |
| m + 6 | m + 14 | m + 22 | m + 30 | -32768 to 32767 | 8000 to FFFF hex, 0000 to 7FFF hex | 4000 (0FA0 hex) | Rate-of-change value H (high limit) alarm setting (Set at rate-of-change scaling value.) |
| m + 7 | m + 15 | m + 23 | m + 31 | -32768 to 32767 | 8000 to FFFF hex, 0000 to 7FFF hex | 0 (0000 hex) | Rate-of-change value L (low limit) alarm setting (Set at rate-of-change scaling value.) |
| | | | | Zero/span adjustment | | | |
| m + 8 | m + 16 | m + 24 | m + 32 | 0 to 32000 | 0000 to 7D00 hex | 10000 (2710 hex) | Gain for span adjustment (set value x 0.0001%) |

| DM Area address | | | | Data range | | Default | Data contents |
|--|-------------|-------------|-------------|---------------------|------------------------------------|------------------|--|
| Input No. 1 | Input No. 2 | Input No. 3 | Input No. 4 | Decimal | Hexadecimal | | |
| m + 9 | m + 17 | m + 25 | m + 33 | -32000 to 32000 | 8300 to FFFF hex, 0000 to 7D00 hex | 0 (0000 hex) | Zero adjustment value (Set at process value scaling value.) |
| Setting Group 2 (initial settings area): Parameters that are transferred one time from the CPU Unit to the Thermocouple Input Unit if word m contains other than 12345 when the PLC is turned ON or the Thermocouple Input Unit is restarted. | | | | | | | |
| m + 34 | m + 49 | m + 64 | m + 79 | 0 to 12 | 0000 to 000C hex | 0 (0000 hex) | Sensor type 0: B, 1: E, 2: J, 3: K, 4: N, 5: R, 6: S, 7: T, 8: mV, 9: L, 10: U, 11: Wre5-26, 12: PLII |
| Process value input range settings | | | | | | | |
| m + 35 | m + 50 | m + 65 | m + 80 | -32000 to 32000 | 8300 to FFFF hex, 0000 to 7D00 hex | 4000 (0FA0 hex) | Maximum input signal value (set value x 0.1°C/°F or mV) |
| m + 36 | m + 51 | m + 66 | m + 81 | -32000 to 32000 | 8300 to FFFF hex, 0000 to 7D00 hex | 0 (0000 hex) | Minimum input signal value (set value x 0.1°C/°F or mV) |
| m + 37 | m + 52 | m + 67 | m + 82 | 0, 1 | 0000, 0001 hex | 0 (0000 hex) | Unit 0: °C, 1: °F |
| m + 38 | m + 53 | m + 68 | m + 83 | 0, 1 | 0000, 0001 hex | 0 (0000 hex) | Process value overrange direction at time of input disconnection 0: High; 1: Low |
| Process value scaling | | | | | | | |
| m + 39 | m + 54 | m + 69 | m + 84 | -32000 to 32000 | 8300 to FFFF hex, 0000 to 7D00 hex | 4000 (0FA0 hex) | Value stored for maximum value in range (span) |
| m + 40 | m + 55 | m + 70 | m + 85 | -32000 to 32000 | 8300 to FFFF hex, 0000 to 7D00 hex | 0 (0000 hex) | Value stored for minimum value in range (zero) |
| Alarm supplementary functions | | | | | | | |
| m + 41 | m + 56 | m + 71 | m + 86 | 0 to 32000 | 0000 to 7D00 hex | 40 (0028 hex) | Alarm hysteresis (Set at process value scaling value. Shared with process value alarm and rate-of-change alarm.) |
| m + 42 | m + 57 | m + 72 | m + 87 | 0 to 60 | 0000 to 003C hex | 0 (0000 hex) | Alarm ON-delay time (Unit: s) (Shared with process value alarm and rate-of-change alarm.) |
| Rate-of-change function | | | | | | | |
| m + 43 | m + 58 | m + 73 | m + 88 | -32000 to 32000 | 8300 to FFFF hex, 0000 to 7D00 hex | 4000 (0FA0 hex) | Rate-of-change range setting Maximum rate-of-change value (Set value industrial unit; comparison time interval) |
| m + 44 | m + 59 | m + 74 | m + 89 | -32000 to 32000 | 8300 to FFFF hex, 0000 to 7D00 hex | -4000 (F060 hex) | |
| m + 45 | m + 60 | m + 75 | m + 90 | 1 to 16 | 0001 to 0010 hex | 1 (0001 hex) | Rate-of-change comparison time interval (Unit: s) |
| m + 46 | m + 61 | m + 76 | m + 91 | -32000 to 32000 | 8300 to FFFF hex, 0000 to 7D00 hex | 4000 (0FA0 hex) | Rate-of-change value scaling Value stored for maximum value in range |
| m + 47 | m + 62 | m + 77 | m + 92 | -32000 to 32000 | 8300 to FFFF hex, 0000 to 7D00 hex | -4000 (F060 hex) | |
| Mean value processing function | | | | | | | |
| m + 48 | m + 63 | m + 78 | m + 93 | 1 to 128 | 0001 to 0080 hex | 25 (0019 hex) | Number of process values for calculating moving average for mean value processing |
| Display parameter | | | | | | | |
| m + 94 | m + 95 | m + 96 | m + 97 | 0 to 99, 100 to 1XX | 0000 to 0063 hex, 0064 to 0XXX hex | 0 (0000 hex) | Address of Data Range Error (See note.) |

| DM Area address | | | | Data range | | Default | Data contents |
|---|-------------|-------------|-------------|------------|------------------|---------|--|
| Input No. 1 | Input No. 2 | Input No. 3 | Input No. 4 | Decimal | Hexadecimal | | |
| Expansion Setting Area allocations | | | | | | | |
| m+98 | | | | 0 to 5 | 0000 to 0005 hex | --- | Expansion Setting Area allocations: 0: Not used; 1: DM; 2: CIO; 3: W; 4: H; 5: EM |
| m+99 | | | | 0 to 32767 | 0000 to 7FFF hex | --- | Expansion Setting Area first word |

- Note**
1. The ERC indicator on the Unit's front panel will light if an out-of-range setting is made in either Setting Group 1 (continuously refreshed area) or 2 (initial settings area), or in the Expansion Setting Area. The offset from word m to the first word containing the out-of-range error will be stored as the Address of Data Range Error in the DM Area in four digits hexadecimal. If the first memory address containing the out-of-range error is in the Expansion Setting Area, the Address of Data Range Error will be over +100 (or +100 if the first word in the Expansion Setting Area is an error).
 2. When specifying an expansion setting area, be sure that it does not overlap with other areas that are being used. If areas overlap, the words that are allocated may be overwritten, resulting in unexpected operation.
 3. When specifying the first word in an expansion setting area, be sure that the end of the memory area is not exceeded.

Expansion Setting Area

First word: word o. (o = address specified in word m+99 in the area specified in word m+98 in the DM Area)

| DM Area address | | | | Data range | | Default | Data contents |
|---|-------------|-------------|-------------|-----------------|------------------------------------|------------------|--|
| Input No. 1 | Input No. 2 | Input No. 3 | Input No. 4 | Decimal | Hexadecimal | | |
| Setting Group 3 (initial settings area): Parameters that are transferred one time from the CPU Unit to the Thermocouple Input Unit if word m contains other than 12345, and if Expansion Setting Area settings are allocated, when the PLC is turned ON or the Thermocouple Input Unit is restarted. | | | | | | | |
| | | | | | | | Expansion Control/Monitor Area settings |
| o | | | | 0 to 5 | 0000 to 0005 hex | --- | Expansion Control/Monitor Area allocation 0: Not used. 1: DM; 2: CIO; 3: W; 4: H; 5: EM |
| o+1 | | | | 0 to 32767 | 0000 to 7FFF hex | --- | Expansion Control/Monitor Area first word |
| | | | | | | | Zero/span adjustment supplementary function |
| o+2 | o+13 | o+24 | o+35 | 0 to 32000 | 0000 to 7D00 hex | 10000 (2710 hex) | Span adjustment position (Input span percentage) |
| o+3 | o+14 | o+25 | o+36 | -32000 to 32000 | 8300 to FFFF hex, 0000 to 7D00 hex | 0 (0000 hex) | Zero adjustment position (Input span percentage) |
| o+4 | o+15 | o+26 | o+37 | 0 to 9999 | 0000 to 270F hex | 365 (016D hex) | Zero/span adjustment period (Unit: Days) |
| o+5 | o+16 | o+27 | o+38 | 0 to 9999 | 0000 to 270F hex | 30 (001E hex) | Notice of days remaining (Unit: Days) |
| | | | | | | | Not used. |
| o+6 | o+17 | o+28 | o+39 | --- | --- | 0 (0000 hex) | Not used. |
| o+7 | o+18 | o+29 | o+40 | | | | |
| o+8 | o+19 | o+30 | o+41 | | | | |
| | | | | | | | Top and valley hold |
| o+9 | o+20 | o+31 | o+42 | 0 to 32000 | 0000 to 7D00 hex | 40 (0028 hex) | Hysteresis |
| | | | | | | | Not used. |

| DM Area address | | | | Data range | | Default | Data contents |
|-----------------|-------------|-------------|-------------|------------|-------------|--------------|---------------|
| Input No. 1 | Input No. 2 | Input No. 3 | Input No. 4 | Decimal | Hexadecimal | | |
| 0+10 | 0+21 | 0+32 | 0+43 | --- | --- | 0 (0000 hex) | Not used. |
| 0+11 | 0+22 | 0+33 | 0+44 | | | | |
| 0+12 | 0+23 | 0+34 | 0+45 | | | | |

- Note**
1. When specifying an expansion control/monitor area be sure that it does not overlap with other areas that are being used. If areas overlap, the words that are allocated may be overwritten, resulting in unexpected operation.
 2. When specifying the first word in an expansion control/monitor area be sure that the end of the memory area is not exceeded.

CIO Area Allocations

First word: n = 2000 + unit number × 10 (unit number: 0 to 95)

| Direction | Word | Bit | Name | | Data range | Contents |
|-------------------------------------|------|-----|-------------|--|------------|--|
| Thermocouple Input Unit to CPU Unit | n | 00 | Input No. 1 | Process value LL (low low limit) alarm | 0, 1 | 0: Process value > Set value 1: Process value ≤ Set value |
| | | 01 | | Process value L (low limit) alarm | 0, 1 | |
| | | 02 | | Process value H (high limit) alarm | 0, 1 | |
| | | 03 | | Process value HH (high high limit) alarm | 0, 1 | |
| | | 04 | Input No. 2 | Process value LL (low low limit) alarm | 0, 1 | Same as for input No. 1. |
| | | 05 | | Process value L (low limit) alarm | 0, 1 | |
| | | 06 | | Process value H (high limit) alarm | 0, 1 | |
| | | 07 | | Process value HH (high high limit) alarm | 0, 1 | |
| | | 08 | Input No. 3 | Process value LL (low low limit) alarm | 0, 1 | Same as for input No. 1. |
| | | 09 | | Process value L (low limit) alarm | 0, 1 | |
| | | 10 | | Process value H (high limit) alarm | 0, 1 | |
| | | 11 | | Process value HH (high high limit) alarm | 0, 1 | |
| | | 12 | Input No. 4 | Process value LL (low low limit) alarm | 0, 1 | Same as for input No. 1. |
| | | 13 | | Process value L (low limit) alarm | 0, 1 | |
| | | 14 | | Process value H (high limit) alarm | 0, 1 | |
| | | 15 | | Process value HH (high high limit) alarm | 0, 1 | |

| Direction | Word | Bit | Name | | Data range | Contents | |
|---|-------|---------------------------------|----------------------------------|-------------|---|--|--|
| Thermocouple Input Unit to CPU Unit | n + 1 | 00 to 15 | Input No. 1 process value | | -32768 to 32767 (8000 to FFFF hex, 0000 to 7FFF hex) | The present process value is stored according to the scaling set in the allocated words of the DM Area. | |
| | n + 2 | 00 to 15 | Input No. 2 process value | | -32768 to 32767 (8000 to FFFF hex, 0000 to 7FFF hex) | | |
| | n + 3 | 00 to 15 | Input No. 3 process value | | -32768 to 32767 (8000 to FFFF hex, 0000 to 7FFF hex) | | |
| | n + 4 | 00 to 15 | Input No. 4 process value | | -32768 to 32767 (8000 to FFFF hex, 0000 to 7FFF hex) | | |
| | n + 5 | 00 to 15 | Input No. 1 rate-of-change value | | -32768 to 32767 (8000 to FFFF hex, 0000 to 7FFF hex) | The process value rate of change is stored according to the scaling set in the allocated words of the DM Area. | |
| | n + 6 | 00 to 15 | Input No. 2 rate-of-change value | | -32768 to 32767 (8000 to FFFF hex, 0000 to 7FFF hex) | | |
| | n + 7 | 00 to 15 | Input No. 3 rate-of-change value | | -32768 to 32767 (8000 to FFFF hex, 0000 to 7FFF hex) | | |
| | n + 8 | 00 to 15 | Input No. 4 rate-of-change value | | -32768 to 32767 (8000 to FFFF hex, 0000 to 7FFF hex) | | |
| | n + 9 | 00 | | Input No. 1 | Rate-of-change value L (low limit) alarm | 0, 1 | 0: Rate-of-change value > Set value 1: Rate-of-change value ≤ Set value |
| | | | | | Rate-of-change value H (high limit) alarm | 0, 1 | 0: Rate-of-change value < Set value 1: Rate-of-change value ≥ Set value |
| | | 02 | | Input No. 2 | Rate-of-change value L (low limit) alarm | 0, 1 | Same as for input No. 1. |
| | | | | | Rate-of-change value H (high limit) alarm | | |
| | | 04 | | Input No. 3 | Rate-of-change value L (low limit) alarm | | |
| | | | | | Rate-of-change value H (high limit) alarm | | |
| | | 06 | | Input No. 4 | Rate-of-change value L (low limit) alarm | | |
| Rate-of-change value H (high limit) alarm | | | | | | | |
| 08 | | | Input No. 1 input disconnection | | 0, 1 | 0: Normal 1: Disconnection | |
| 09 | | | Input No. 2 input disconnection | | 0, 1 | | |
| 10 | | | Input No. 3 input disconnection | | 0, 1 | | |
| 11 | | Input No. 4 input disconnection | | 0, 1 | | | |

| Direction | Word | Bit | Name | Data range | Contents |
|-------------------------------------|-------|-----|------------------------------------|------------|--|
| Thermocouple Input Unit to CPU Unit | n + 9 | 12 | Cold junction sensor error | 0, 1 | 0: Normal 1: Error |
| | | 13 | Zero/span adjustment period end | 0, 1 | 0: Adjustment enabled 1: Adjustment ended |
| | | 14 | Zero/span adjustment period notice | 0, 1 | 0: Adjustment enabled 1: Notice period |
| | | 15 | Not used. | 0 | |

Expansion Control/Monitor Area Allocations

First word: word p. (p = address specified in word o+1 in the area specified in word o in the Expansion Setting Area)

| Direction | Word | Bit | Name | Data range | Contents | |
|-------------------------------------|----------|----------|---|---|---|---|
| CPU Unit to Thermocouple Input Unit | p | 00 to 15 | Not used. | 0 (0000 hex) | Not used. | |
| | p+1 | 00 | Input No. 1 hold function selection | 0, 1 | 0: Peak and bottom 1: Top and valley | |
| | | 01 | Input No. 2 hold function selection | | | |
| | | 02 | Input No. 3 hold function selection | | | |
| | | 03 | Input No. 4 hold function selection | | | |
| | | 04 to 07 | Not used. | 0 | Not used. | |
| | | 08 | Input No. 1 hold start | 0, 1 | 0: Do not hold. 1: Hold | |
| | | 09 | Input No. 2 hold start | | | |
| | | 10 | Input No. 3 hold start | | | |
| | | 11 | Input No. 4 hold start | | | |
| | | 12 | Input No. 1 hold value reset | 0, 1 | 0: Normal operation 1: Reset hold value. | |
| | | 13 | Input No. 2 hold value reset | | | |
| | | 14 | Input No. 3 hold value reset | | | |
| | | 15 | Input No. 4 hold value reset | | | |
| | | p+2 | 00 | Input No. 1 zero/span adjustment update bit | 0, 1 | 0: Normal operation 1: Update adjustment date (Remains ON while writing external FROM.) |
| | | | 01 | Input No. 2 zero/span adjustment update bit | | |
| | 02 | | Input No. 3 zero/span adjustment update bit | | | |
| | 03 | | Input No. 4 zero/span adjustment update bit | | | |
| | 04 to 15 | | Not used. | 0 | Not used. | |

| Direction | Word | Bit | Name | | Data range | Contents | |
|-------------------------------------|----------|---|--------------------------|---|--------------------|--|-----------|
| Thermocouple Input Unit to CPU Unit | p+3 | 00 | Input No. 1 | Zero/span adjustment period end | 0, 1 | 0: Adjustment enabled. 1: Adjustment period end | |
| | | 01 | | Zero/span adjustment period notice | 0, 1 | 0: Adjustment enabled. 1: Notice period in effect. Remains set to 1 if the zero/span adjustment bit has never been ON. | |
| | | 02 | Input No. 2 | Zero/span adjustment period end | 0, 1 | Same as for input No. 1. | |
| | | 03 | | Zero/span adjustment period notice | | | |
| | | 04 | Input No. 3 | Zero/span adjustment period end | | | |
| | | 05 | | Zero/span adjustment period notice | | | |
| | | 06 | Input No. 4 | Zero/span adjustment period end | | | |
| | | 07 | | Zero/span adjustment period notice | | | |
| | | 08 | External FROM Error Flag | | | | 0, 1 |
| | 09 to 15 | Not used. | | 0 | | | Not used. |
| | p+4 | 00 to 15 | Input No. 1 | Day of final adjustment date | 0100 to 3100 (BCD) | Remains set to FFFF if the zero/span adjustment bit has never been ON. | |
| | p+5 | 00 to 15 | | Year and month of final adjustment date | 0001 to 9912 (BCD) | | |
| | p+6 | 00 to 15 | Input No. 2 | Day of final adjustment date | 0100 to 3100 (BCD) | | |
| | p+7 | 00 to 15 | | Year and month of final adjustment date | 0001 to 9912 (BCD) | | |
| | p+8 | 00 to 15 | Input No. 3 | Day of final adjustment date | 0100 to 3100 (BCD) | | |
| | p+9 | 00 to 15 | | Year and month of final adjustment date | 0001 to 9912 (BCD) | | |
| | p+10 | 00 to 15 | Input No. 4 | Day of final adjustment date | 0100 to 3100 (BCD) | | |
| p+11 | 00 to 15 | Year and month of final adjustment date | | 0001 to 9912 (BCD) | | | |
| p+12 to p+15 | 00 to 15 | Not used. | | 0000 | Not used. | | |

| Direction | Word | Bit | Name | | Data range | Contents |
|-------------------------------------|----------|-----------|-------------|---------------------|--|---|
| Thermocouple Input Unit to CPU Unit | p+16 | 00 to 15 | Input No. 1 | Peak/top value | -32728 to +32767 (8000 to FFFF hex, 0000 to 7FFF hex) | Counts the number of repetitions of conditional operations set in the Expansion Setting Area. |
| | p+17 | 00 to 15 | | Bottom/valley value | | |
| | p+18 | 00 to 15 | Input No. 2 | Peak/top value | -32728 to +32767 (8000 to FFFF hex, 0000 to 7FFF hex) | Same as for Input No. 1. |
| | p+19 | 00 to 15 | | Bottom/valley value | | |
| | p+20 | 00 to 15 | Input No. 3 | Peak/top value | | |
| | p+21 | 00 to 15 | | Bottom/valley value | | |
| | p+22 | 00 to 15 | Input No. 4 | Peak/top value | | |
| | p+23 | 00 to 15 | | Bottom/valley value | | |
| p+24 to p+34 | 00 to 15 | Not used. | | 0 (0000 hex) | Not used. | |

Terminal Connection Diagram

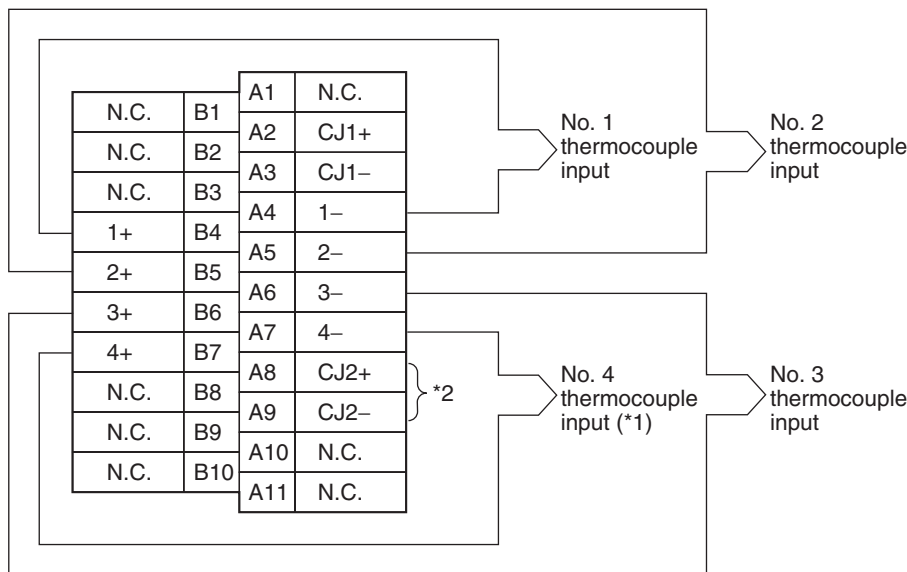

Note Action for Unused Input Terminals

- Short-circuit the positive (+) and negative (-) sides of the thermocouple input section using a lead wire. For example, short terminals A4 and B4 for No. 1 thermocouple input.
- Cold junction sensors are mounted between A2 and A3, and A8 and A9 before shipment. If one of the cold junction sensors is disconnected, cold junction compensation will stop and correct measurement of temperatures cannot be made. Always make sure the cold junction sensors are connected when using the Units.
- Cold junction sensors are calibrated separately for each Unit and connected circuit, so correct temperatures will not be measured if a cold junction

tion sensor from another Unit is used or if the two cold junction sensors in a Unit are swapped. Use the cold junction sensors as they are provided, without making any changes.

- When wiring No. 4 thermocouple input terminals (*1 in the above diagram), remove the cold junction sensor between terminals CJ2+ and CJ2- at the bottom (*2 in the above diagram), connect the No. 4 thermocouple input, and then reconnect the cold junction sensor. Any attempt to connect No. 4 thermocouple input without removing the cold junction sensor may result in damage to the cold junction sensor.
- Always ground the GR terminal on the Power Supply Unit of the PLC.
- If the input device uses a voltage generator, temperature compensator, or similar device, then ground the input device if it has a ground terminal.

Terminal Block Diagram

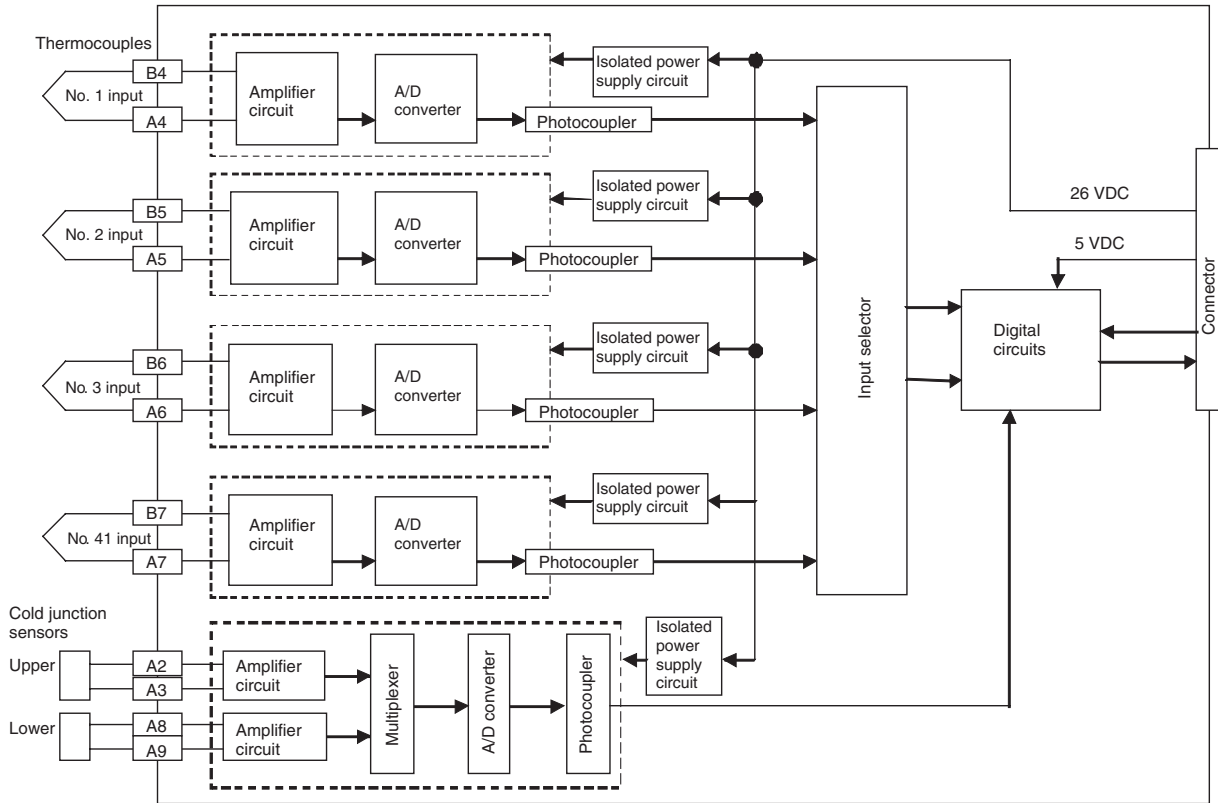

Error Processing

Conversion Data Does Not Change.

| Probable cause | Remedy |
|--|--|
| The gain for span adjustment is set to 0. | Set the gain for span adjustment to a value other than 0. |
| The minimum and maximum values for process value scaling are either the same or are set extremely low. | Set the minimum and maximum values correctly. |
| The sensor type, input range, or process value scaling is not set correctly. | Check and correct the settings. |
| An input device is malfunctioning, input wiring is faulty, or wiring is disconnected. | Check whether the input voltage or current has changed. Check for faulty or disconnected wiring. Check whether a wiring disconnection has been detected in the I/O Area. |

Values are Not Converted as Intended.

| Probable cause | Remedy |
|---|--|
| The sensor type, input range, or process value scaling is not set correctly. | Check and correct the settings. |
| The zero/span adjustment data is incorrect. | Check and correct the zero/span adjustment settings. |
| Cold junction compensation is not operating. | Check the Cold Junction Error Flag. |
| A compensation conductor has not been used or a different compensation conductor is used. | Use the correct compensation conductor for the thermocouple. |
| Incorrect input wiring (incorrect thermocouple or compensation conductor polarity.) | Correct the input wiring. |

Converted Values are Unstable.

| Probable cause | Remedy |
|--|---|
| Input signals are being affected by external noise. | Change the connection paths of the input signal lines. (Separate them from sources of noise or use shielded cable.) |
| | Insert a 0.01 to 0.1 μ F ceramic capacitor between the positive (+) and negative (-) input terminals. |
| | Increase the number of values for calculating the moving average in mean value processing. |
| The process value scaling value is greater than the Unit's resolution. | Reduce the process value scaling value. |
| The input signal range setting is too small. | Match the input signal range to the internal ranges. |

2-3 CS1W-PTS51 Isolated-type Thermocouple Input Unit

Overview

The CS1W-PTS51 Isolated-type Thermocouple Input Unit provides four direct thermocouple inputs, and sends the data to the CPU Unit each cycle. All inputs are isolated.

CS1W-PTS51

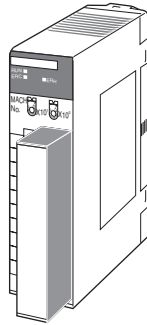

System Configuration

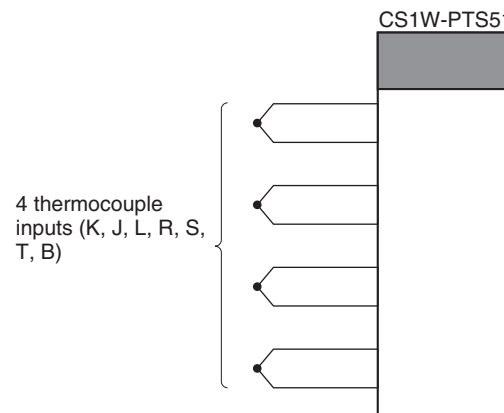

Features

- Up to four thermocouples can be connected for each Unit (with four separate settings for temperature sensors and input ranges).
- There is isolation between channels, so unwanted circuit paths between thermocouple inputs can be prevented.
- A variety of temperature specifications are supported. Any of the following can be selected for thermocouple input: K, J, L, R, S, T, B. (Decimal points can be selected for K, J, and L.)
- Temperature sensor values are transmitted to the CPU Unit in four digits hexadecimal. (Binary or BCD can be selected for the data output format.)
- Process value alarm (with two internal alarms in memory and one external alarm output for each input).
- Alarm ON-delay timer and hysteresis for process value.
- Zero/span adjustment capability during operation.
- Sensor error detection.
- Maximum or minimum process value can be specified for when a sensor error is detected.

Model Information

| Unit classification | Model number | Inputs | Temperature sensor types |
|----------------------------------|--------------|--------|--------------------------|
| CS-series Special I/O Unit | CS1W-PTS51 | 4 | K, J, L, R, S, T, B |

Block Diagram (Order of Processing)

The processing for the inputs is as shown in the following diagram.

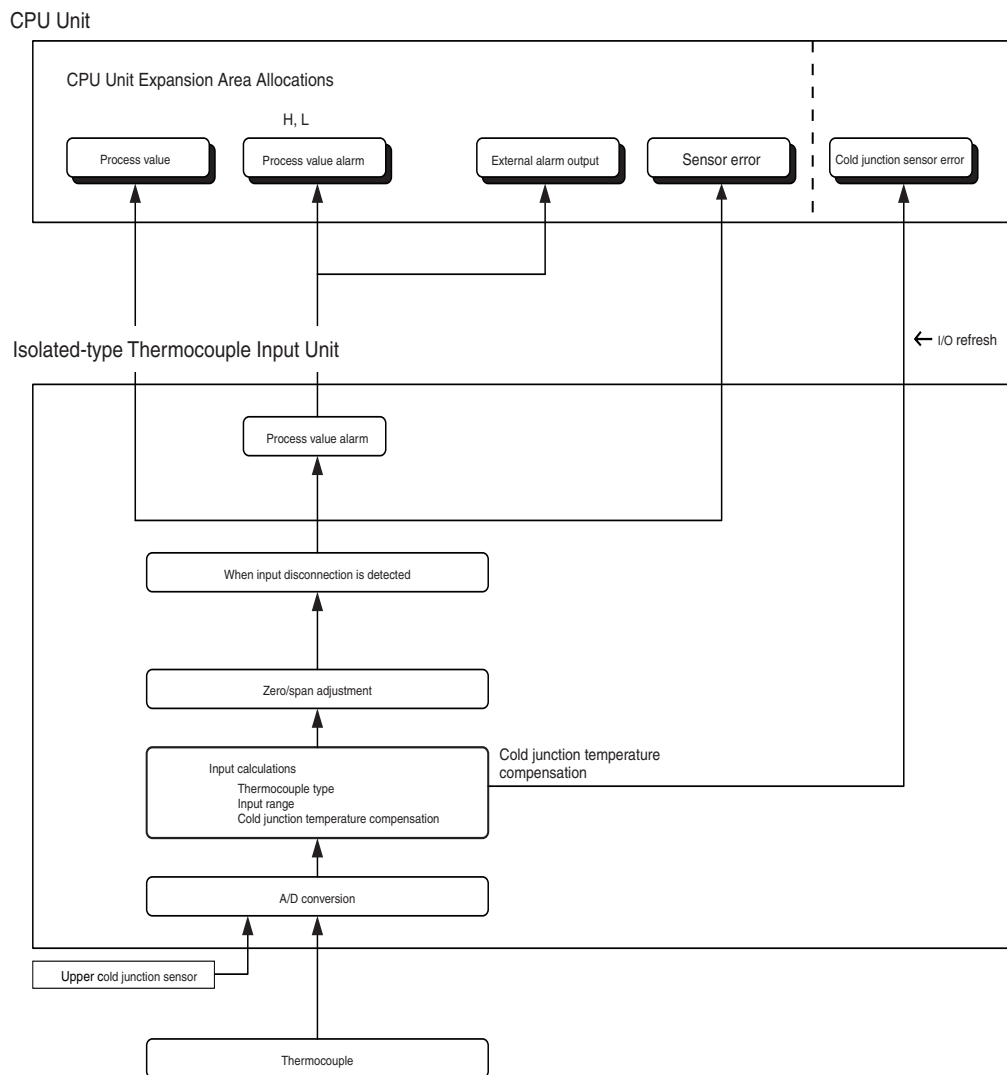

Specifications

| Item | | Specifications |
|--|--|--|
| Model | | CS1W-PTS51 |
| Applicable PLC | | CS Series |
| Unit classification | | CS-series Special I/O Unit |
| Mounting position | | CS-series CPU Rack or CS-series Expansion Rack (Cannot be mounted to C200H Expansion I/O Rack or SYSMAC BUS Remote I/O Slave Rack.) |
| Maximum number of Units | | 80 (within the allowable current consumption and power consumption range) |
| Unit numbers | | 00 to 95 (Cannot duplicate Special I/O Unit numbers.) |
| Areas for data exchange with CPU Unit | Special I/O Unit Area | 10 words/Unit Isolated-type Thermocouple Input Unit to CPU Unit: All process values, process value alarms (L, H), conversion data enabled flags, sensor errors, cold junction sensor errors |
| | DM Area words allocated to Special I/O Units | 100 words/Unit CPU Unit to Isolated-type Thermocouple Input Unit: Temperature sensor type, input range (user set), process value alarm setting (L, H), zero/span adjustment value. |
| Number of temperature sensor inputs | | 4 |
| Temperature sensor types | | The sensor type be set individually for each of 4 inputs, which are each selectable from K, J, L, R, S, T, B. |
| Data storage in the CIO Area | | The actual process data in the input range is stored in four digits hexadecimal (binary or BCD values) in the allocated words in the CIO Area. |
| Accuracy (25°C) (See note.) | | With Celsius selected: $\pm 0.3\%$ of PV or $\pm 1^\circ\text{C}$, whichever is greater, ± 1 digit max. With fahrenheit selected: $\pm 0.3\%$ of PV or $\pm 2^\circ\text{F}$, whichever is greater, ± 1 digit max. However, the accuracy of K and T at -100°C or lower and L is $\pm 2^\circ\text{C} \pm 1$ digit max. The accuracy of R and S at 200°C or lower is $\pm 3^\circ\text{C} \pm 1$ digit max. The accuracy of B at 400°C or lower is not specified. PV: Process value data |
| Temperature characteristic | | Refer to <i>Temperature Characteristics According to Thermocouple Type</i> on page 102. |
| Warmup time | | 30 min |
| Conversion period | | 250 ms/4 inputs. |
| Maximum time to store data in CPU Unit | | Conversion period + one CPU Unit cycle |
| Sensor error detection | | Detects sensor error at each input and turns ON the Sensor error Flag. Hardware detection time: Approx. 0.5 s max. The process value overrange direction for when a sensor error occurs can be specified. (High: Set input range $+20^\circ\text{C}$ or $+20^\circ\text{F}$; low: Set input range -20°C or -20°F) |
| Functions | Process value alarm | Process value 2-point alarm (HH, H, LL, L), alarm hysteresis, and ON-delay timer (0 to 60 s) are available. External alarm outputs: One per input (H or L). |
| | External alarm outputs | NPN outputs (with short-circuit protection) External power supply voltage: 20.4 to 26.4 V DC Max. switching capacity: 100 mA (for one output) Leakage current: 0.3 mA max. Residual voltage: 3 V max. |
| Isolation | | Between inputs and PLC signals: Transformer for power supply and photocoupler for signals. Between each input: Transformer for power supply and photocoupler for signals. |
| Insulation resistance | | 20 M Ω max. (at 500 V DC). Between all output and NC terminals and external AC terminals (Power Supply Unit) Between all input terminals and external AC terminals (Power Supply Unit) Between all input terminals and all output terminals Between all external DC terminals (input, output, and NC terminals) and FG plate Between all input and output terminals and all NC terminals |

| Item | Specifications |
|---|---|
| Dielectric strength | Between all output and NC terminals and external AC terminals (Power Supply Unit) 2,000 VAC, 50/60 Hz 1 min., detection current: 1 mA Between all input terminals and external AC terminals (Power Supply Unit) Between all input terminals and all output terminals Between all external DC terminals (input, output, and NC terminals) and FG plate 1,000 VAC, 50/60 Hz 1 min., detection current: 1 mA Between all channels 500 VAC, 50/60 Hz 1 min., detection current: 1 mA |
| External connections | Terminal block (detachable) |
| Unit number settings | Set by rotary switches on front panel, from 0 to 95. |
| Indicators | Seven LED indicators on front panel (for normal operation, errors detected at the Thermocouple Input Unit, errors related to the CPU Unit, and four indicators for external alarm outputs.) |
| Effect on CPU Unit cycle time | 0.4 ms |
| Current consumption (supplied from Power Supply Unit) | 5 V DC at 250 mA max. |
| Dimensions | 35 × 130 × 126 mm (W × H × D) Note The height including the Backplane is 145 mm. |
| Weight | 450 g max. |

Note The heat generated by a Unit will dramatically change the accuracy specifications when more than one C200HW-PA209R or CS1W-ID291 Unit is mounted side-by-side.

The following accuracy specifications apply under such conditions.

With Celsius selected:

±0.3% of PV or ±1.3°C, whichever is greater, ±1 digit max.

With Fahrenheit selected:

±0.3% of PV or ±3°F, whichever is greater, ±1 digit max.

However, the accuracy of K and T at -100°C or less and L is ±3°C ±1 digit max. The accuracy of R and S at 200°C or less is ±4°C ±1 digit max.

The accuracy of B at 400°C or less is not specified.

Sensor Type and Input Range

The Temperature Sensor type and input range are set in the allocated words in the DM Area for every four inputs.

The measurable data range is ±20 digits wider than the sensor input range.

| Set-ting | Input | °C | | | | °F | | | |
|----------|---------------------------------------|--|--------------------------------|------------------------------------|--|--------------------------------|---|--|--|
| | | 16-bit binary | BCD | | 16-bit binary | BCD | | | |
| | | | F□□□ indicates minus sign. | Leftmost bit indicates minus sign. | | F□□□ indicates minus sign. | Leftmost bit indicates minus sign. | | |
| 0 | K: -200 to 1300°C (-300 to 2300°F) | FF38 to FFFF to 0514 (-200 to -1 to 1300) | F200 to 1300 (-200 to 1300) | 8200 to 1300 (-200 to 1300) | FED4 to FFFF to 08FC (-300 to -1 to 2300) | F300 to 2300 (-300 to 2300) | F300 to 2300 (-300 to 2300) | | |
| 1 | K: 0.0 to 500°C (0.0 to 900.0°F) | 0000 to 1388 (0.0 to 500.0) | 0000 to 5000 (0.0 to 500.0) | 0000 to 5000 (0.0 to 500.0) | 0000 to 2328 (0.0 to 900.0) | 0000 to 9000 (0.0 to 900.0) | 0000 to 7999 (See note 3.) (0.0 to 799.9) | | |
| 2 | J: -100 to 850°C (-100 to 1500°F) | FF9C to FFFF to 0352 (-100 to -1 to 850) | F100 to 0850 (-100 to 850) | 8100 to 0850 (-100 to 850) | FF9C to FFFF to 05DC (-100 to -1 to 1500) | F100 to 1500 (-100 to 1500) | 8100 to 1500 (-100 to 1500) | | |
| 3 | J: 0.0 to 400.0°C (0.0 to 750.0°F) | 0000 to 0FA0 (0.0 to 400.0) | 0000 to 4000 (0.0 to 400.0) | 0000 to 4000 (0.0 to 400.0) | 0000 to 1D4C (0.0 to 750.0) | 0000 to 7500 (0.0 to 750.0) | 0000 to 7500 (0.0 to 750.0) | | |

| Setting | Input | °C | | | °F | | |
|---------|--|--|---|------------------------------------|--|---|------------------------------------|
| | | 16-bit binary | BCD | | 16-bit binary | BCD | |
| | | | F□□□ indicates minus sign. | Leftmost bit indicates minus sign. | | F□□□ indicates minus sign. | Leftmost bit indicates minus sign. |
| 4 | T: -200 to 400°C (-300 to 700.0°F) | F830 to FFFF to 0FA0 (-200.0 to -0.1 to 400.0) | F999 to 4000 (See note 3.) (-99.9 to 400.0) | A000 to 4000 (-200.0 to 400.0) | F448 to FFFF to 1B58 (-300.0 to -0.1 to 700.0) | F999 to 7000 (See note 3.) (-99.9 to 700.0) | B000 to 7000 (-300.0 to 700.0) |
| 5 | L: -100 to 850°C (-100 to 1500°F) | FF9C to FFFF to 0352 (-100 to -1 to 850) | F100 to 0850 (-100 to 850) | 8100 to 0850 (-100 to 850) | FF9C to FFFF to 05DC (-100 to -1 to 1500) | F100 to 1500 (-100 to 1500) | 8100 to 1500 (-100 to 1500) |
| 6 | L: 0.0 to 400.0°C (0.0 to 750.0°F) | 0000 to 0FA0 (0.0 to 400.0) | 0000 to 4000 (0.0 to 400.0) | 0000 to 4000 (0.0 to 400.0) | 0000 to 1D4C (0.0 to 750.0) | 0000 to 7500 (0.0 to 750.0) | 0000 to 7500 (0.0 to 750.0) |
| 7 | R: 0 to 1700°C (0 to 3000°F) | 0000 to 06A4 (0 to 1700) | 0000 to 1700 (0 to 1700) | 0000 to 1700 (0 to 1700) | 0000 to 0BB8 (0 to 3000) | 0000 to 3000 (0 to 3000) | 0000 to 3000 (0 to 3000) |
| 8 | S: 0 to 1700°C (0 to 3000°F) | 0000 to 06A4 (0 to 1700) | 0000 to 1700 (0 to 1700) | 0000 to 1700 (0 to 1700) | 0000 to 0BB8 (0 to 3000) | 0000 to 3000 (0 to 3000) | 0000 to 3000 (0 to 3000) |
| 9 | B: 400 to 1800°C (See note 2.) (750 to 3200°F) | 0190 to 0708 (400 to 1800) | 0400 to 1800 (400 to 1800) | 0400 to 1800 (400 to 1800) | 02EE to 0C80 (750 to 3200) | 0750 to 3200 (750 to 3200) | 0750 to 3200 (750 to 3200) |

- Note**
1. If the indication range is exceeded, a sensor error will occur and the sensor error bit will turn ON. The process value will be clamped at the lower or upper limit of the indication range, depending on the setting for data direction at sensor error.
 2. The lower limit for B thermocouples is 0°C/°F.
 3. The indicator range for BCD display will be clamped at the lower (or upper) limit in the region between the lower (or upper) limit of the setting range and the point where a sensor error occurs.
 For 0.1°C/0.1°F indication with minus sign indicated by leftmost 4 bits (bits 12 to 15): Lower limit = -99.9, Upper limit = 999.9.
 For 0.1°C/0.1°F indication with minus sign indicated by leftmost bit (bit 15): Lower limit = -799.9, Upper limit = 799.9.

Temperature Characteristics According to Thermocouple Type

| Thermocouple | Temperature range | Set value error when ambient temperature changes by 1°C |
|--------------|-------------------|---|
| R | 0 to 200°C | ±0.43°C |
| | 200 to 1,000°C | ±0.29°C |
| | 1,000 to 1,700°C | ±285 ppm of PV |
| S | 0 to 200°C | ±0.43°C |
| | 200 to 1,000°C | ±0.29°C |
| | 1,000 to 1,700°C | 285 ppm of PV |
| B | 400°C or less | Not specified. |
| | 400 to 800°C | ±0.43°C |
| | 800 to 1,000°C | ±0.29°C |
| | 1,000 to 1,800°C | 285 ppm of PV |
| K | -200 to -100°C | ±0.29°C |
| | -100 to 400°C | ±0.11°C |
| | 400 to 1,300°C | ±285 ppm of PV |
| J | -100 to 400°C | ±0.11°C |
| | 400 to 850°C | ±285 ppm of PV |
| T | -200 to -100°C | ±0.29°C |
| | -100 to 400°C | ±0.11°C |
| L | -100 to 400°C | ±0.11°C |
| | 400 to 850°C | ±285 ppm of PV |

The measured temperature error is calculated as shown in the following example.

| Item | Details |
|-------------------------------|---|
| Ambient temperature | 30°C |
| Thermocouple type | K |
| Measured temperature (PV) | 500°C |
| Reference accuracy (25°C) | ±0.3°C of PV or ±1°C, whichever is greater, ±1 digit. In this example, ±1.5°C. |
| Temperature characteristics | 400 to 1,300°C: 285 ppm of PV. In this example, 285 ppm × 500°C = 0.143°C. |
| Change in ambient temperature | 5°C (25 to 30°C). |

Overall accuracy =
 Reference accuracy + Temperature characteristic × Change in ambient temperature = ±1.5°C + ±0.143°C × 5 = Approx. ±2.2°C ± 1 digit.

DM Area Allocations

First word: m = D20000 + unit number × 100 (unit number: 0 to 95)

| DM Area address | | | | Data range | | Default | Data contents |
|--|-------------|-------------|-------------|--------------------------------|------------------|---|--|
| Input No. 1 | Input No. 2 | Input No. 3 | Input No. 4 | Decimal | Hexadecimal | | |
| m | | | | 12345, 0 | 3039, 0000 hex | 0000 hex | Default block read command Specifies the direction of data transfer when the PLC is turned ON or the Unit is restarted for DM words m+1 to m+93. <ul style="list-style-type: none"> 12345 (3039 hex): The data in words m+1 to m+93 is transferred from the Thermocouple Input Unit to the CPU Unit. When the transfer is completed, the value will become 0000 hex. Other than 12345 (3039 hex) (such as 0000 hex): The data in the allocated words of DM Area is transferred from the CPU Unit to the Thermocouple Input Unit. |
| Display parameter | | | | | | | |
| m + 1 | | | | 0 to 34 | 0000 to 0022 hex | 0 (0000 hex) | Address of Data Range Error (See note 1.) |
| Setting Group 1 (continuously refreshed area): Parameters that are continuously refreshed during PLC operation (regardless of the CPU Unit's operation mode) | | | | | | | |
| | | | | | | Process value alarm settings | |
| m + 2 | m + 6 | m + 10 | m + 14 | Low to high limit for sensors. | | 1300 (0514 hex) | Process value H (high limit) alarm setting |
| m + 3 | m + 7 | m + 11 | m + 15 | | | -200 (FF38 hex) | Process value L (low limit) alarm setting |
| | | | | | | Span adjustment value | |
| m + 4 | m + 8 | m + 12 | m + 16 | 0 to 9999 | 0000 to 270F hex | 1000 (03E8 hex) | m+35 contains 0: Set value × 0.001 |
| | | | | 0 to 32000 | 0000 to 7D00 hex | 10000 (2710 hex) | m+35 contains 1: Set value × 0.0001 |
| | | | | | | Zero adjustment value | |
| m + 5 | m + 9 | m + 13 | m + 17 | -9999 to 9999 | D8F1 to 270F hex | 0 (0000 hex) | Set value × 0.1 |
| Setting Group 2 (initial settings area): Parameters that are transferred one time from the CPU Unit to the Thermocouple Input Unit if word m contains other than 12345 when the PLC is turned ON or the Thermocouple Input Unit is restarted. | | | | | | | |
| | | | | | | Operation settings (See note 2.) | |
| m + 18 | | | | (See note 2.) | (See note 2.) | 0 (0000 hex) | 00 to 03: Temperature unit (°C or °F) 04 to 07: Data display (binary or BCD) 08 to 11: Minus sign display format for BCD display 12 to 15: Data direction at sensor error |
| | | | | | | Sensor type | |
| m + 19 | m + 23 | m + 27 | m + 31 | 0 to 9 | 0000 to 0009 hex | 0 (0000 hex) | 0: K, 1: K (with decimal point), 2: J, 3: J (with decimal point), 4: T, 5: L, 6: L (with decimal point), 7: R, 8: S, 9: B |
| | | | | | | External alarm output mode | |
| m + 20 | m + 24 | m + 28 | m + 32 | 0, 1 | 0000, 0001 hex | 0 (0000 hex) | Select either high limit or low limit alarm output. 0: High limit alarm; 1: Low limit alarm |
| | | | | | | Alarm hysteresis | |
| m + 21 | m + 25 | m + 29 | m + 33 | 0 to 9999 | 0000 to 270F hex | 0 (0000 hex) | Set value × 0.1 |
| | | | | | | Alarm ON-delay time | |
| m + 22 | m + 26 | m + 30 | m + 34 | 0 to 60 | 0000 to 003C hex | 0 (0000 hex) | Unit: s |
| m + 35 | | | | 0, 1 | 0000, 0001 hex | 1 (See note 3.) | Span adjustment mode 0: 1/1,000 1: 1/10,000 |

Note 1. The ERC indicator on the Unit's front panel will light if an out-of-range setting is made in either Setting Group 1 (continuously refreshed area) or 2

(initial settings area). The offset from word m to the first word containing the out-of-range error will be stored as the Address of Data Range Error in the DM Area in four digits hexadecimal.

2. The operation settings are shown in the following table.

| Word | Bits | Description | Settings |
|------|------|---|---|
| m+18 | 00 | Temperature unit setting | 0: °C 1: °F |
| | 04 | Data format | 0: Binary (Negative values are given as 2's complements). 1: BCD |
| | 08 | Minus sign display format for BCD display | 0: "F" used to indicate the minus sign. 1: Leftmost bit used to indicate the minus sign. The setting is disabled if bits 04 to 07 are set to 0. |
| | 12 | Data direction at sensor error | 0: Goes to upper limit at sensor error 1: Goes to lower limit at sensor error |

Example: For a temperature in degrees Celsius (°C), a binary data format, and a data direction at sensor error of "lower limit," word m+18 will contain 1000.

3. Indicates the value after transferring the default value (set when 12345 is written to word m).

CIO Area Allocations

First word: n = 2000 + unit number × 10 (unit number: 0 to 95)

| Direction | Word | Bit | Name | | Data range | Contents | |
|-------------------------------------|----------|-----------|-------------|------------------------------------|---------------------------|--|--|
| Thermocouple Input Unit to CPU Unit | n | 00 | Input No. 1 | Process value L (low limit) alarm | 0, 1 | 0: Process value > Set value 1: Process value ≤ Set value | |
| | | 01 | | Process value H (high limit) alarm | 0, 1 | 0: Process value < Set value 1: Process value ≥ Set value | |
| | | 02 | Input No. 2 | Process value L (low limit) alarm | 0, 1 | Same as for input No. 1. | |
| | | 03 | | Process value H (high limit) alarm | 0, 1 | | |
| | | 04 | Input No. 3 | Process value L (low limit) alarm | 0, 1 | | |
| | | 05 | | Process value H (high limit) alarm | 0, 1 | | |
| | | 06 | Input No. 4 | Process value L (low limit) alarm | 0, 1 | | |
| | | 07 | | Process value H (high limit) alarm | 0, 1 | | |
| | 08 to 15 | Not used. | | | | | |
| | n + 1 | 00 to 15 | Input No. 1 | Process value | Depends on type of input. | | Stores data in the data range specified for the input type ±20 digits. |
| | n + 2 | 00 to 15 | Input No. 2 | | | | |
| | n + 3 | 00 to 15 | Input No. 3 | | | | |
| | n + 4 | 00 to 15 | Input No. 4 | | | | |

| Direction | Word | Bit | Name | Data range | Contents | |
|-------------------------------------|----------|---|-------------|--------------|-------------------------------------|-----------------------|
| Thermocouple Input Unit to CPU Unit | n + 5 | 00 to 15 | Not used. | | | |
| | n + 6 | 00 to 15 | Not used. | | | |
| | n + 7 | 00 to 15 | Not used. | | | |
| | n + 8 | 00 to 15 | Not used. | | | |
| | n + 9 | 00 | Input No. 1 | Sensor error | 0, 1 | 0: Normal 1: Error |
| | | 01 | Input No. 2 | | 0, 1 | |
| | | 02 | Input No. 3 | | 0, 1 | |
| | | 03 | Input No. 4 | | 0, 1 | |
| | n + 9 | 04 | Not used. | | | |
| | | 05 | Not used. | | | |
| | | 06 | Not used. | | | |
| | | 07 | Not used. | | | |
| n + 9 | 08 | Cold junction sensor error | | 0, 1 | 0: Normal 1: Error | |
| n + 9 | 09 to 14 | Not used. | | | | |
| n + 9 | 15 | Conversion data enabled flag (See note.) | | 0, 1 | 0: Data disabled 1: Data enabled | |

Note The Conversion Data Enabled Flag remains OFF after the PLC is turned ON or the Unit is restarted until the AD conversion data becomes stable (approximately 2 to 4 s), then is ON during operation.

Terminal Connection Diagram

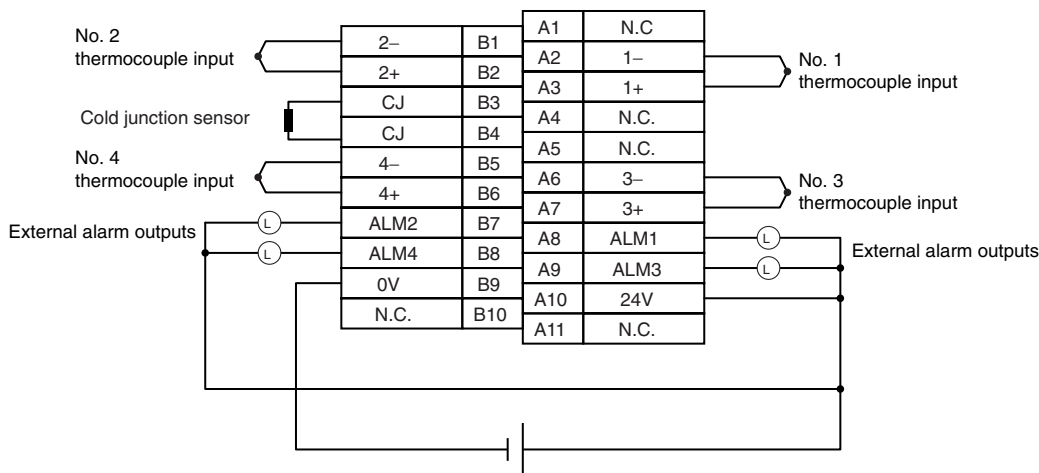

Note Action for Unused Input Terminals

- Short-circuit the positive (+) and negative (-) sides of the thermocouple input section using a lead wire. For example, short terminals A3 and A2 for No. 1 thermocouple input.
- Cold junction sensors are mounted before shipment. If one of the cold junction sensors is disconnected, cold junction compensation will stop and correct measurement of temperatures cannot be made. Always make sure the cold junction sensors are connected when using the Units.
- Cold junction sensors are calibrated separately for each Unit and connected circuit, so correct temperatures will not be measured if a cold junction sensor from another Unit is used or if the two cold junction sensors in a Unit are swapped. Use the cold junction sensors as they are provided, without making any changes.

- Do not connect anything to NC terminals. Do not use NC terminals as relay terminals.
- Always ground the GR terminal on the Power Supply Unit of the PLC.
- If the input device uses a voltage generator, temperature compensator, or similar device, then ground the input device if it has a ground terminal.

Terminal Block Diagram

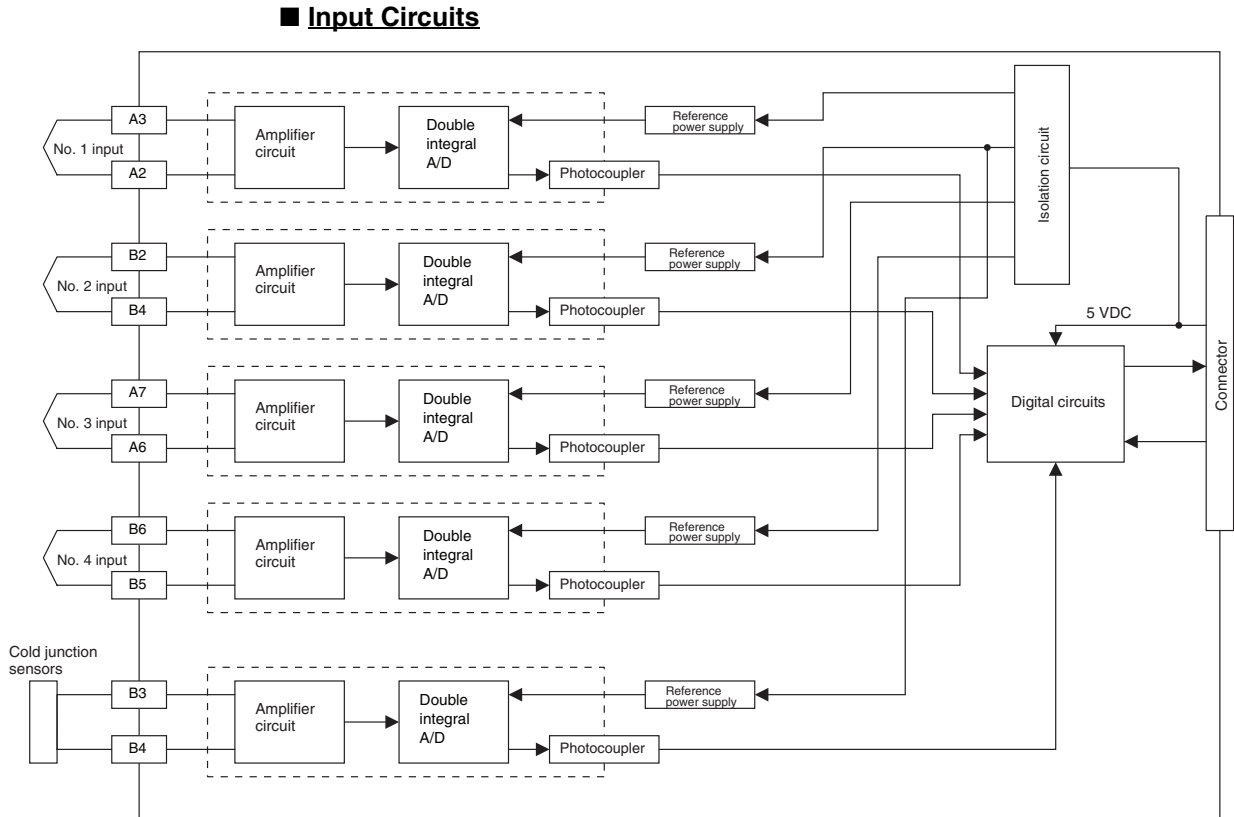

■ Output Circuits

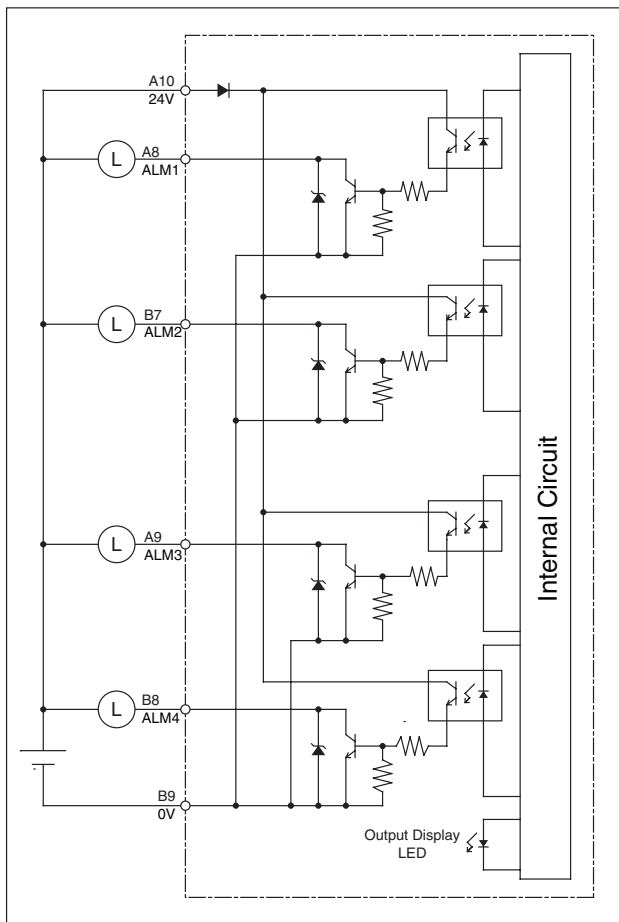

Error Processing

Conversion Data Does Not Change.

| Probable cause | Remedy |
|---|--|
| The gain for span adjustment is set to 0. | Set the gain for span adjustment to a value other than 0. |
| The sensor type, input range, or process value scaling is not set correctly. | Check and correct the settings. |
| An input device is malfunctioning, input wiring is faulty, or wiring is disconnected. | Check whether the input voltage or current has changed. Check for faulty or disconnected wiring. Check whether a sensor error has been detected in the I/O Area. |

Values are Not Converted as Intended.

| Probable cause | Remedy |
|--|---|
| The sensor type is not set correctly. | Check and correct the settings. |
| The zero/span adjustment data is incorrect. | Check and correct the zero/span adjustment settings. |
| Cold junction compensation is not operating. | Check the Cold Junction Error Flag. |
| A compensation conductor has not been used or a different compensation conductor is used. | Use the correct compensation conductor for the thermocouple. |
| Incorrect input wiring (incorrect thermocouple or compensation conductor polarity.) | Correct the input wiring. |
| Thermocouple lead or compensating conductor is too long and measurements are being affected by conductor resistance. | Use a thicker compensating conductor. Change the wiring position and shorten the compensating conductor. |
| The terminal block temperature is not uniform due to radiated heat from peripheral devices. | Mount the unit in a position unaffected by radiated heat. |

Converted Values are Unstable.

| Probable cause | Remedy |
|---|---|
| Input signals are being affected by external noise. | Change the connection paths of the input signal lines. (Separate them from sources of noise or use shielded cable.) |
| | Insert a 0.01 to 0.1 μ F ceramic capacitor between the positive (+) and negative (-) input terminals. |
| An airflow is hitting the Unit terminal block. | Move the terminal block to a position unaffected by airflow. |

2-4 CS1W-PTS55 Isolated-type Thermocouple Input Unit

Overview

The CS1W-PTS55 Isolated-type Thermocouple Input Unit provides 8 direct thermocouple inputs, and sends the data to the CPU Unit each cycle. All inputs are isolated.

CS1W-PTS55

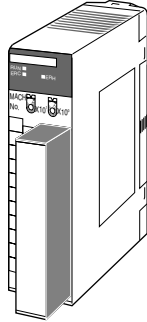

System Configuration

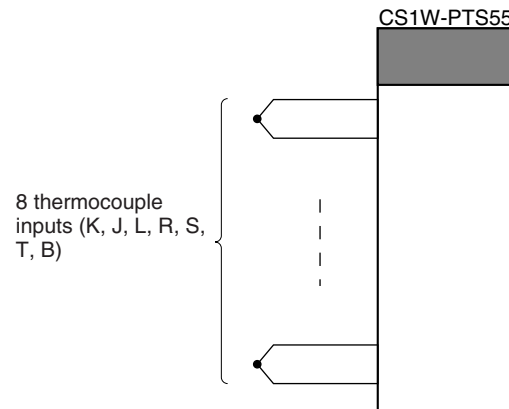

Features

- Up to 8 thermocouples can be connected for each Unit (with 8 separate settings for temperature sensors and input ranges).
- There is isolation between channels, so unwanted circuit paths between thermocouple inputs can be prevented.
- A variety of temperature specifications are supported. Any of the following can be selected for thermocouple input: K, J, L, R, S, T, B. (Decimal points can be selected for K, J, and L.)
- Temperature sensor values are transmitted to the CPU Unit in four digits hexadecimal. (Binary or BCD can be selected for the data output format.)
- Process value alarms (Two internal alarms per input can be output to memory and two alarms per input can be output to specified I/O memory area addresses using indirect address specifications).
- Alarm ON-delay timer and hysteresis for process value.
- Zero/span adjustment capability during operation.
- Sensor error detection.
- Maximum or minimum process value can be specified for when a sensor error is detected.

Model Information

| Unit classification | Model number | Inputs | Temperature sensor types |
|----------------------------------|--------------|--------|--------------------------|
| CS-series Special I/O Unit | CS1W-PTS55 | 8 | K, J, L, R, S, T, B |

Block Diagram (Order of Processing)

The processing for the inputs is as shown in the following diagram.

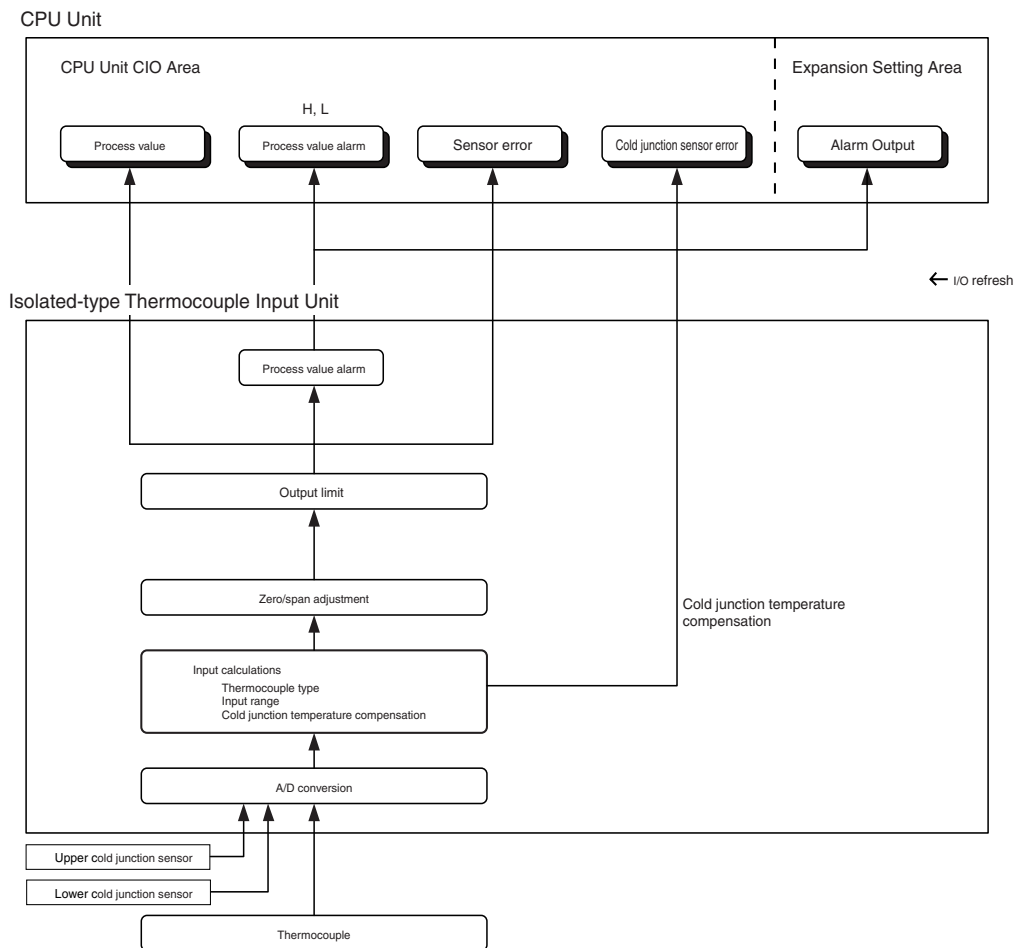

Specifications

| Item | | Specifications |
|--|--|--|
| Model | | CS1W-PTS55 |
| Applicable PLC | | CS Series |
| Unit classification | | CS-series Special I/O Unit |
| Mounting position | | CS-series CPU Rack or CS-series Expansion Rack (Cannot be mounted to C200H Expansion I/O Rack or SYSMAC BUS Remote I/O Slave Rack.) |
| Maximum number of Units | | 80 (within the allowable current consumption and power consumption range) |
| Unit numbers | | 00 to 95 (Cannot duplicate Special I/O Unit numbers.) |
| Areas for data exchange with CPU Unit | Special I/O Unit Area | 10 words/Unit Isolated-type Thermocouple Input Unit to CPU Unit: All process values, process value alarms (L, H), conversion data enabled flags, sensor errors, cold junction sensor errors |
| | DM Area words allocated to Special I/O Units | 100 words/Unit CPU Unit to Isolated-type Thermocouple Input Unit: Temperature sensor type, input range (user set), process value alarm setting (L, H), zero/span adjustment value. |
| | Expansion Setting Area | 1 word/Unit CPU Unit to Isolated-type Thermocouple Input Unit: Process Value Alarm |
| Number of temperature sensor inputs | | 8 |
| Temperature sensor types | | The sensor type be set individually for each of 8 inputs, which are each selectable from K, J, L, R, S, T, B ("Not used" can be selected). |
| Data storage in the CIO Area | | The actual process data in the input range is stored in four digits hexadecimal (binary or BCD values) in the allocated words in the CIO Area. |
| Accuracy (25°C) | | With Celsius selected: $\pm 0.3\%$ of PV or $\pm 1^\circ\text{C}$, whichever is greater, ± 1 digit max. With fahrenheit selected: $\pm 0.3\%$ of PV or $\pm 2^\circ\text{F}$, whichever is greater, ± 1 digit max. However, the accuracy of K and T at -100°C or lower and L is $\pm 2^\circ\text{C} \pm 1$ digit max. The accuracy of R and S at 200°C or lower is $\pm 3^\circ\text{C} \pm 1$ digit max. The accuracy of B at 400°C or lower is not specified. PV: Process value data |
| Temperature characteristic | | Refer to <i>Temperature Characteristics According to Thermocouple Type</i> on page 113. |
| Warmup time | | 30 min |
| Conversion period | | 250 ms/8 inputs. |
| Maximum time to store data in CPU Unit | | Conversion period + one CPU Unit cycle |
| Sensor error detection | | Detects sensor error at each input and turns ON the Sensor error Flag. Hardware detection time: Approx. 0.5 s max. The process value overrange direction for when a sensor error occurs can be specified. (High: Set input range $+20^\circ\text{C}$ or $+20^\circ\text{F}$; low: Set input range -20°C or -20°F) |
| Functions | Process value alarm | Process value 2-point alarm (H, L), alarm hysteresis, and ON-delay timer (0 to 60 s) are available. Two alarms per input (H, L) can be output to addresses in the CIO Area specified in the Expansion Setting Area. |
| Isolation | | Between inputs and PLC signals: Transformer for power supply and photocoupler for signals. Between each input: Transformer for power supply and photocoupler for signals. |
| Insulation resistance | | 20 M Ω max. (at 500 V DC). Between all input terminals and external AC terminals (Power Supply Unit) Between all external DC terminals (input and NC terminals) and FG plate Between all input and all NC terminals |

| Item | Specifications |
|---|--|
| Dielectric strength | Between NC terminals and external AC terminals (Power Supply Unit) 2,000 VAC, 50/60 Hz 1 min., detection current: 1 mA Between all input terminals and external AC terminals (Power Supply Unit) Between all external DC terminals (input and NC terminals) and FG plate 1000 VAC, 50/60 Hz 1 min., detection current: 1 mA Between all channels 500 VAC, 50/60 Hz 1 min., detection current: 1 mA |
| External connections | Terminal block (detachable) |
| Unit number settings | Set by rotary switches on front panel, from 0 to 95. |
| Indicators | Three LED indicators on front panel (for normal operation, errors detected at the Unit, errors related to the CPU Unit) |
| Effect on CPU Unit cycle time | 0.4 ms |
| Current consumption (supplied from Power Supply Unit) | 5 V DC at 180 mA max. 26 V DC at 60 mA max. |
| Dimensions | 35 × 130 × 126 mm (W × H × D) Note The height including the Backplane is 145 mm. |
| Weight | 450 g max. |

Sensor Type and Input Range

The Temperature Sensor type and input range are set in the allocated words in the DM Area for every four inputs.

The measurable data range is ±20 digits wider than the sensor input range.

| Set-ting | Input | °C | | | | °F | | | |
|----------|---------------------------------------|---|---|------------------------------------|---|---|---|--|--|
| | | 16-bit binary | BCD | | 16-bit binary | BCD | | | |
| | | | F□□□ indicates minus sign. | Leftmost bit indicates minus sign. | | F□□□ indicates minus sign. | Leftmost bit indicates minus sign. | | |
| 0 | K: -200 to 1300°C (-300 to 2300°F) | FF38 to FFFF to 0514 (-200 to -1 to 1300) | F200 to 1300 (-200 to 1300) | 8200 to 1300 (-200 to 1300) | FED4 to FFFF to 08FC (-300 to -1 to 2300) | F300 to 2300 (-300 to 2300) | F300 to 2300 (-300 to 2300) | | |
| 1 | K: 0.0 to 500°C (0.0 to 900.0°F) | 0000 to 1388 (0.0 to 500.0) | 0000 to 5000 (0.0 to 500.0) | 0000 to 5000 (0.0 to 500.0) | 0000 to 2328 (0.0 to 900.0) | 0000 to 9000 (0.0 to 900.0) | 0000 to 7999 (See note 3.) (0.0 to 799.9) | | |
| 2 | J: -100 to 850°C (-100 to 1500°F) | FF9C to FFFF to 0352 (-100 to -1 to 850) | F100 to 0850 (-100 to 850) | 8100 to 0850 (-100 to 850) | FF9C to FFFF to 05DC (-100 to -1 to 1500) | F100 to 1500 (-100 to 1500) | 8100 to 1500 (-100 to 1500) | | |
| 3 | J: 0.0 to 400.0°C (0.0 to 750.0°F) | 0000 to 0FA0 (0.0 to 400.0) | 0000 to 4000 (0.0 to 400.0) | 0000 to 4000 (0.0 to 400.0) | 0000 to 1D4C (0.0 to 750.0) | 0000 to 7500 (0.0 to 750.0) | 0000 to 7500 (0.0 to 750.0) | | |
| 4 | T: -200 to 400°C (-300 to 700.0°F) | F830 to FFFF to 0FA0 (-200.0 to -0.1 to 400.0) | F999 to 4000 (See note 3.) (-99.9 to 400.0) | A000 to 4000 (-200.0 to 400.0) | F448 to FFFF to 1B58 (-300.0 to -0.1 to 700.0) | F999 to 7000 (See note 3.) (-99.9 to 700.0) | B000 to 7000 (-300.0 to 700.0) | | |
| 5 | L: -100 to 850°C (-100 to 1500°F) | FF9C to FFFF to 0352 (-100 to -1 to 850) | F100 to 0850 (-100 to 850) | 8100 to 0850 (-100 to 850) | FF9C to FFFF to 05DC (-100 to -1 to 1500) | F100 to 1500 (-100 to 1500) | 8100 to 1500 (-100 to 1500) | | |
| 6 | L: 0.0 to 400.0°C (0.0 to 750.0°F) | 0000 to 0FA0 (0.0 to 400.0) | 0000 to 4000 (0.0 to 400.0) | 0000 to 4000 (0.0 to 400.0) | 0000 to 1D4C (0.0 to 750.0) | 0000 to 7500 (0.0 to 750.0) | 0000 to 7500 (0.0 to 750.0) | | |
| 7 | R: 0 to 1700°C (0 to 3000°F) | 0000 to 06A4 (0 to 1700) | 0000 to 1700 (0 to 1700) | 0000 to 1700 (0 to 1700) | 0000 to 0BB8 (0 to 3000) | 0000 to 3000 (0 to 3000) | 0000 to 3000 (0 to 3000) | | |

| Setting | Input | °C | | | °F | | |
|---------|--|-------------------------------|-------------------------------|------------------------------------|-------------------------------|-------------------------------|------------------------------------|
| | | 16-bit binary | BCD | | 16-bit binary | BCD | |
| | | | F□□□ indicates minus sign. | Leftmost bit indicates minus sign. | | F□□□ indicates minus sign. | Leftmost bit indicates minus sign. |
| 8 | S: 0 to 1700°C (0 to 3000°F) | 0000 to 06A4 (0 to 1700) | 0000 to 1700 (0 to 1700) | 0000 to 1700 (0 to 1700) | 0000 to 0BB8 (0 to 3000) | 0000 to 3000 (0 to 3000) | 0000 to 3000 (0 to 3000) |
| 9 | B: 400 to 1800°C (See note 2.) (750 to 3200°F) | 0190 to 0708 (400 to 1800) | 0400 to 1800 (400 to 1800) | 0400 to 1800 (400 to 1800) | 02EE to 0C80 (750 to 3200) | 0750 to 3200 (750 to 3200) | 0750 to 3200 (750 to 3200) |

- Note**
- If the indication range is exceeded, a sensor error will occur and the sensor error bit will turn ON. The process value will be clamped at the lower or upper limit of the indication range, depending on the setting for data direction at sensor error.
 - The lower limit for B thermocouples is 0°C/°F.
 - The indicator range for BCD display will be clamped at the lower (or upper) limit in the region between the lower (or upper) limit of the setting range and the point where a sensor error occurs.
 For 0.1°C/0.1°F indication with minus sign indicated by leftmost 4 bits (bits 12 to 15): Lower limit = -99.9, Upper limit = 999.9.
 For 0.1°C/0.1°F indication with minus sign indicated by leftmost bit (bit 15): Lower limit = -799.9, Upper limit = 799.9.

Temperature Characteristics According to Thermocouple Type

| Thermocouple | Temperature range | Set value error when ambient temperature changes by 1°C |
|--------------|-------------------|---|
| R | 0 to 200°C | ±0.43°C |
| | 200 to 1,000°C | ±0.29°C |
| | 1,000 to 1,700°C | ±285 ppm of PV |
| S | 0 to 200°C | ±0.43°C |
| | 200 to 1,000°C | ±0.29°C |
| | 1,000 to 1,700°C | 285 ppm of PV |
| B | 400°C or less | Not specified. |
| | 400 to 800°C | ±0.43°C |
| | 800 to 1,000°C | ±0.29°C |
| | 1,000 to 1,800°C | 285 ppm of PV |
| K | -200 to -100°C | ±0.29°C |
| | -100 to 400°C | ±0.11°C |
| | 400 to 1,300°C | ±285 ppm of PV |
| J | -100 to 400°C | ±0.11°C |
| | 400 to 850°C | ±285 ppm of PV |
| T | -200 to -100°C | ±0.29°C |
| | -100 to 400°C | ±0.11°C |
| L | -100 to 400°C | ±0.11°C |
| | 400 to 850°C | ±285 ppm of PV |

The measured temperature error is calculated as shown in the following example.

| Item | Details |
|---------------------------|---------|
| Ambient temperature | 30°C |
| Thermocouple type | K |
| Measured temperature (PV) | 500°C |

| Item | Details |
|-------------------------------|---|
| Reference accuracy (25°C) | ±0.3°C of PV or ±1°C, whichever is greater, ±1 digit. In this example, ±1.5°C. |
| Temperature characteristics | 400 to 1,300°C: 285 ppm of PV. In this example, 285 ppm × 500°C = 0.143°C. |
| Change in ambient temperature | 5°C (25 to 30°C). |

Overall accuracy =
Reference accuracy + Temperature characteristic × Change in ambient temperature = ±1.5°C + ±0.143°C × 5 = Approx. ±2.2°C ±1 digit.

DM Area Allocations

First word: m = D20000 + unit number × 100 (unit number: 0 to 95)

| DM Area address | | | | | | | | Data range | | Default | Data contents |
|--|-------------|-------------|-------------|-------------|-------------|-------------|-------------|--------------------------------|----------------------------|---|--|
| Input No. 1 | Input No. 2 | Input No. 3 | Input No. 4 | Input No. 5 | Input No. 6 | Input No. 7 | Input No. 8 | Decimal | Hexadecimal | | |
| m | | | | | | | | 12345, 0 | 3039, 0000 hex | 0000 hex | Default block read command Specifies the direction of data transfer when the PLC is turned ON or the Unit is restarted for DM words m+1 to m+60. <ul style="list-style-type: none"> 12345 (3039 hex): The data in words m+1 to m+60 is transferred from the Thermocouple Input Unit to the CPU Unit. When the transfer is completed, the value will become 0000 hex. Other than 12345 (3039 hex) (such as 0000 hex): The data in the allocated words of DM Area is transferred from the CPU Unit to the Thermocouple Input Unit. |
| Display parameter | | | | | | | | | | | |
| m+1 | | | | | | | | 0 to 59 | 0000 to 003B hex | 0 (0000 hex) | Address of Data Range Error (See note 1.) |
| Setting Group 1 (continuously refreshed area): Parameters that are continuously refreshed during PLC operation (regardless of the CPU Unit's operation mode) | | | | | | | | | | | |
| | | | | | | | | | | Process value alarm settings | |
| m+2 | m+6 | m+10 | m+14 | m+18 | m+22 | m+26 | m+30 | Low to high limit for sensors. | | 1300 (0514 hex) | Process value H (high limit) alarm setting |
| m+3 | m+7 | m+11 | m+15 | m+19 | m+23 | m+27 | m+31 | | | -200 (FF38 hex) | Process value L (low limit) alarm setting |
| | | | | | | | | | | Span adjustment value | |
| m+4 | m+8 | m+12 | m+16 | m+20 | m+24 | m+28 | m+32 | 0 to 32000 | 0000 to 7D00 hex | 10000 (2710 hex) | Set value × 0.0001 |
| | | | | | | | | | | Zero adjustment value | |
| m+5 | m+9 | m+13 | m+17 | m+21 | m+25 | m+29 | m+33 | -9999 to 9999 | D8F1 to 270F hex | 0 (0000 hex) | Set value × 0.1 |
| Setting Group 2 (initial settings area): Parameters that are transferred one time from the CPU Unit to the Thermocouple Input Unit if word m contains other than 12345 when the PLC is turned ON or the Thermocouple Input Unit is restarted. | | | | | | | | | | | |
| | | | | | | | | | | Operation settings (See note 2.) | |
| m +34 | | | | | | | | (See note 2.) | (See note 2.) | 0 (0000 hex) | 00: Temperature unit (°C or °F) 01: Data unit 04: Data display (binary or BCD) 08: Minus sign display format for BCD display 12: Data direction at sensor error |
| | | | | | | | | | | Sensor type | |
| m+35 | m+38 | m+41 | m+44 | m+47 | m+50 | m+53 | m+56 | 0 to 9, 15 | 0000 to 0009 hex, 000F hex | 0 (0000 hex) | 0: K, 1: K (with decimal point), 2: J, 3: J (with decimal point), 4: T, 5: L, 6: L (with decimal point), 7: R, 8: S, 9: B, F: Not used |
| Alarm hysteresis | | | | | | | | | | | |

| DM Area address | | | | | | | | Data range | | Default | Data contents |
|---------------------------------------|-------------|-------------|-------------|-------------|-------------|-------------|-------------|------------|------------------|--------------|--------------------------------------|
| Input No. 1 | Input No. 2 | Input No. 3 | Input No. 4 | Input No. 5 | Input No. 6 | Input No. 7 | Input No. 8 | Decimal | Hexadecimal | | |
| m+36 | m+39 | m+42 | m+45 | m+48 | m+51 | m+54 | m+57 | 0 to 9999 | 0000 to 270F hex | 0 (0000 hex) | Set value × 0.1 |
| Alarm ON-delay time | | | | | | | | | | | |
| m+37 | m+40 | m+43 | m+46 | m+49 | m+52 | m+55 | m+58 | 0 to 60 | 0000 to 003C hex | 0 (0000 hex) | Unit: s |
| Expansion Setting Area enable | | | | | | | | | | | |
| m+59 | | | | | | | | 0, 1 | 0000, 0001 hex | 0 (0000 hex) | 0: Disabled 1: Enabled |
| Expansion Setting Area address | | | | | | | | | | | |
| m+60 (See note 3) | | | | | | | | 0 to 6143 | 0000 to 17FF hex | 0 (0000 hex) | CIO area (fixed) Number of words. |

- Note**
1. The ERC indicator on the Unit's front panel will light if an out-of-range setting is made in either Setting Group 1 (continuously refreshed area) or 2 (initial settings area). The offset from word m to the first word containing the out-of-range error will be stored as the Address of Data Range Error in the DM Area in four digits hexadecimal.
 2. The operation settings are shown in the following table
 3. A range check is not performed for the Expansion Setting Area address set in word m+60. Be sure to check this address before starting actual operation.

| Word | Bits | Description | Settings |
|------|------|---|---|
| m+34 | 00 | Temperature unit setting | 0: °C 1: °F |
| | 01 | Data unit | 0: Follow the setting of the sensor type 1: Display the temperature data to 0.1°C or 0.1°F (Only binary is supported.) |
| | 04 | Data format | 0: Binary (Negative values are given as 2's complements). 1: BCD |
| | 08 | Minus sign display format for BCD display | 0: "F" used to indicate the minus sign. 1: Leftmost bit used to indicate the minus sign. The setting is disabled if bits 04 to 07 are set to 0. |
| | 12 | Data direction at sensor error | 0: Goes to upper limit at sensor error 1: Goes to lower limit at sensor error |

Example: For a temperature in degrees Celsius (°C), a binary data format, and a data direction at sensor error of "lower limit," word m+18 will contain 1000.

Expansion Setting Area

First word: word o. (o = address specified in word m+60 in the DM Area)

| Direction | Word | Bit | Name | | Data range | Contents |
|---|------|-----|-------------|--|------------|--|
| Thermocouple Input Unit to CPU Unit | o | 00 | Input No. 1 | Process value L (low limit) alarm | 0, 1 | 0: Process value > Set value 1: Process value ≤ Set value |
| | | 01 | | Process value H (high limit) alarm | 0, 1 | 0: Process value < Set value 1: Process value ≥ Set value |
| | | 02 | Input No. 2 | Process value L (low limit) alarm | 0, 1 | Same as for input No. 1. |
| | | 03 | | Process value H (high limit) alarm | 0, 1 | |
| | | 04 | Input No. 3 | Process value L (low limit) alarm | 0, 1 | |
| | | 05 | | Process value H (high limit) alarm | 0, 1 | |
| | | 06 | Input No. 4 | Process value L (low limit) alarm | 0, 1 | |
| | | 07 | | Process value H (high limit) alarm | 0, 1 | |
| | | 08 | Input No. 5 | Process value L (low limit) alarm | 0, 1 | |
| | | 09 | | Process value H (high limit) alarm | 0, 1 | |
| | | 10 | Input No. 6 | Process value L (low limit) alarm | 0, 1 | |
| | | 11 | | Process value H (high limit) alarm | 0, 1 | |
| | | 12 | Input No. 7 | Process value L (low limit) alarm | 0, 1 | |
| | | 13 | | Process value H (high limit) alarm | 0, 1 | |
| | | 14 | Input No. 8 | Process value L (low limit) alarm | 0, 1 | |
| | | 15 | | Process value H (high limit) alarm | 0, 1 | |

Note If either of the following changes is made for the Expansion Setting Area for the CS1W-PTS55/PTS56/PDC55, the previous data will be left in the Expansion Setting Area even after the change has been made.
Clear the previous data when changing either of these settings.

- The Expansion Setting Area Enable setting is changed from “enabled” to “disabled.”
- The Expansion Setting Area Address setting is changed while the Expansion Setting Area Enable setting is set to “enabled.”

CIO Area Allocations

First word: n = 2000 + unit number × 10 (unit number: 0 to 95)

| Direction | Word | Bit | Name | | Data range | Contents | |
|-------------------------------------|-------|----------|-------------|------------------------------------|---------------------------|--|--|
| Thermocouple Input Unit to CPU Unit | n | 00 | Input No. 1 | Process value L (low limit) alarm | 0, 1 | 0: Process value > Set value 1: Process value ≤ Set value | |
| | | 01 | | Process value H (high limit) alarm | 0, 1 | 0: Process value < Set value 1: Process value ≥ Set value | |
| | | 02 | Input No. 2 | Process value L (low limit) alarm | 0, 1 | Same as for input No. 1. | |
| | | 03 | | Process value H (high limit) alarm | 0, 1 | | |
| | | 04 | Input No. 3 | Process value L (low limit) alarm | 0, 1 | | |
| | | 05 | | Process value H (high limit) alarm | 0, 1 | | |
| | | 06 | Input No. 4 | Process value L (low limit) alarm | 0, 1 | | |
| | | 07 | | Process value H (high limit) alarm | 0, 1 | | |
| | | 08 | Input No. 5 | Process value L (low limit) alarm | 0, 1 | | |
| | | 09 | | Process value H (high limit) alarm | 0, 1 | | |
| | | 10 | Input No. 6 | Process value L (low limit) alarm | 0, 1 | | |
| | | 11 | | Process value H (high limit) alarm | 0, 1 | | |
| | | 12 | Input No. 7 | Process value L (low limit) alarm | 0, 1 | | |
| | | 13 | | Process value H (high limit) alarm | 0, 1 | | |
| | | 14 | Input No. 8 | Process value L (low limit) alarm | 0, 1 | | |
| | | 15 | | Process value H (high limit) alarm | 0, 1 | | |
| | n + 1 | 00 to 15 | Input No. 1 | Process value | Depends on type of input. | | Stores data in the data range specified for the input type ±20 digits. |
| | n + 2 | 00 to 15 | Input No. 2 | | | | |
| | n + 3 | 00 to 15 | Input No. 3 | | | | |
| | n + 4 | 00 to 15 | Input No. 4 | | | | |
| | n + 5 | 00 to 15 | Input No. 5 | | | | |
| | n + 6 | 00 to 15 | Input No. 6 | | | | |
| | n + 7 | 00 to 15 | Input No. 7 | | | | |
| | n + 8 | 00 to 15 | Input No. 8 | | | | |

| Direction | Word | Bit | Name | Data range | Contents | |
|-------------------------------------|-------|------------------------------|--|--------------|-----------------------|-------------------------------------|
| Thermocouple Input Unit to CPU Unit | n + 9 | 00 | Input No. 1 | Sensor error | 0, 1 | 0: Normal 1: Error |
| | | 01 | Input No. 2 | | 0, 1 | |
| | | 02 | Input No. 3 | | 0, 1 | |
| | | 03 | Input No. 4 | | 0, 1 | |
| | | 04 | Input No. 5 | | 0, 1 | |
| | | 05 | Input No. 6 | | 0, 1 | |
| | | 06 | Input No. 7 | | 0, 1 | |
| | | 07 | Input No. 8 | | 0, 1 | |
| | 08 | Cold junction sensor 1 error | | 0, 1 | 0: Normal 1: Error | |
| | 09 | Cold junction sensor 2 error | | 0, 1 | | |
| | | 10 to 14 | Not used. | | | |
| | | 15 | Conversion data enabled flag (See note.) | | 0, 1 | 0: Data disabled 1: Data enabled |

Note The Conversion Data Enabled Flag remains OFF after the PLC is turned ON or the Unit is restarted until the AD conversion data becomes stable (approximately 2 to 4 s), then is ON during operation.

Terminal Connection Diagram

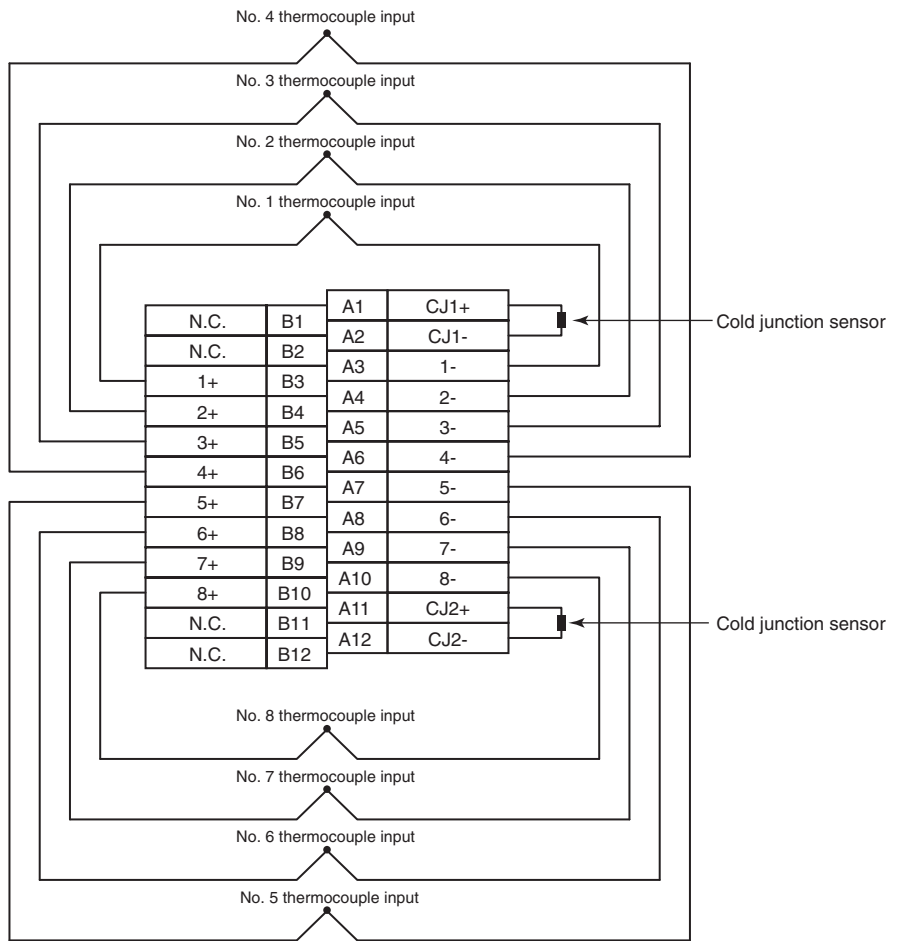

- Note**
- Set the *Sensor type* in Setting Group 2 in the DM Area to “Not used” for any thermocouple inputs that are not used.
 - Cold junction sensors are mounted before shipment. If one of the cold junction sensors is disconnected, cold junction compensation will stop

and correct measurement of temperatures cannot be made. Always make sure the cold junction sensors are connected when using the Units.

- Cold junction sensors are calibrated separately for each Unit and connected circuit, so correct temperatures will not be measured if a cold junction sensor from another Unit is used or if the two cold junction sensors in a Unit are swapped. Use the cold junction sensors as they are provided, without making any changes.
- Do not connect anything to NC terminals. Do not use NC terminals as relay terminals.
- Always ground the GR terminal on the Power Supply Unit of the PLC.
- If the input device uses a voltage generator, temperature compensator, or similar device, then ground the input device if it has a ground terminal.

Terminal Block Diagram

■ **Input Circuits**

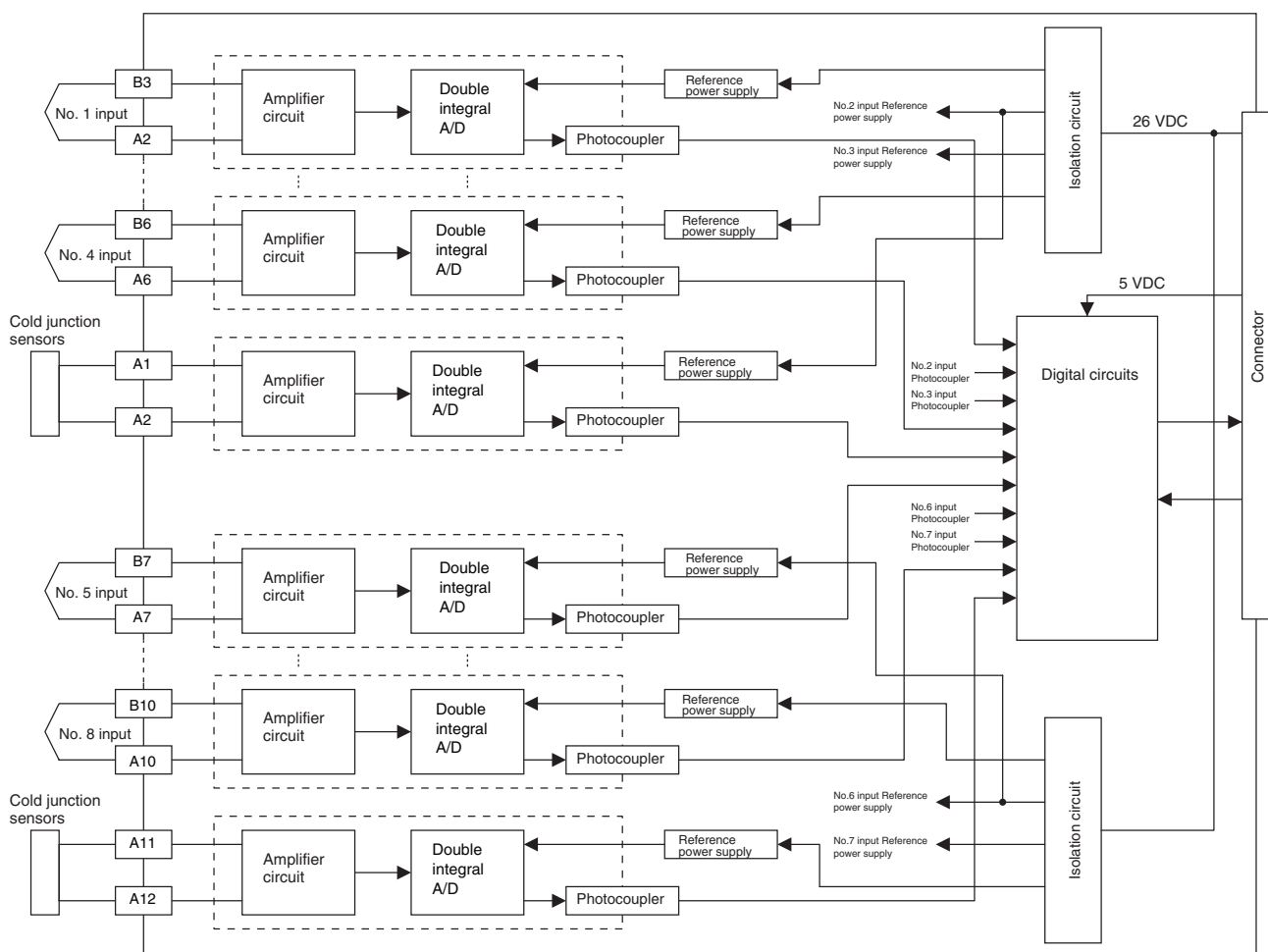

Error Processing

Conversion Data Does Not Change.

| Probable cause | Remedy |
|---|--|
| The gain for span adjustment is set to 0. | Set the gain for span adjustment to a value other than 0. |
| The sensor type, input range, or process value scaling is not set correctly. | Check and correct the settings. |
| An input device is malfunctioning, input wiring is faulty, or wiring is disconnected. | Check whether the input voltage or current has changed. Check for faulty or disconnected wiring. Check whether a sensor error has been detected in the I/O Area. |

Values are Not Converted as Intended.

| Probable cause | Remedy |
|--|---|
| The sensor type is not set correctly. | Check and correct the settings. |
| The zero/span adjustment data is incorrect. | Check and correct the zero/span adjustment settings. |
| Cold junction compensation is not operating. | Check the Cold Junction Error Flag. |
| A compensation conductor has not been used or a different compensation conductor is used. | Use the correct compensation conductor for the thermocouple. |
| Incorrect input wiring (incorrect thermocouple or compensation conductor polarity.) | Correct the input wiring. |
| Thermocouple lead or compensating conductor is too long and measurements are being affected by conductor resistance. | Use a thicker compensating conductor. Change the wiring position and shorten the compensating conductor. |
| The terminal block temperature is not uniform due to radiated heat from peripheral devices. | Mount the unit in a position unaffected by radiated heat. |

Converted Values are Unstable.

| Probable cause | Remedy |
|---|---|
| Input signals are being affected by external noise. | Change the connection paths of the input signal lines. (Separate them from sources of noise or use shielded cable.) |
| | Insert a 0.01 to 0.1 μ F ceramic capacitor between the positive (+) and negative (-) input terminals. |
| An airflow is hitting the Unit terminal block. | Move the terminal block to a position unaffected by airflow. |

2-5 CS1W-PTS02 Isolated-type Resistance Thermometer Input Unit (Pt100 or JPt100)

Overview

The CS1W-PTS02 Isolated-type Resistance Thermometer Input Unit provides four direct platinum resistance thermometer inputs, and sends the data to the CPU Unit each cycle. All inputs are isolated.

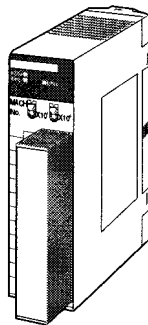

CS1W-PTS02

System Configuration

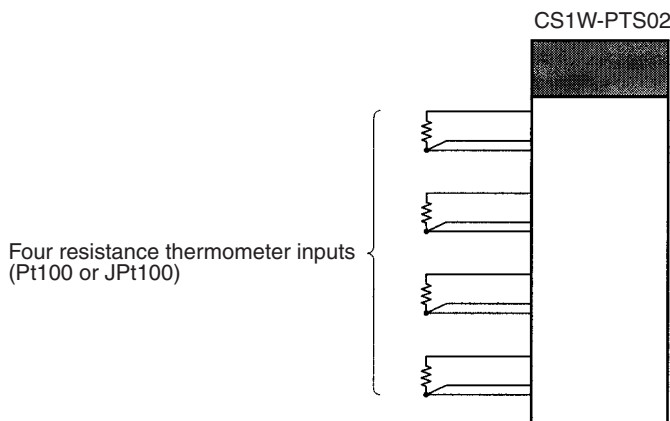

Features

- Up to four platinum resistance thermometers can be connected for each Unit (with four separate settings for temperature sensors and input ranges).
- Pt100 (JIS, IEC) or JPt100 can be selected.
- Temperature sensor values are transmitted to the CPU Unit in four digits hexadecimal.
- Variable input range setting.
- Four values for each process value alarm input.
- ON-delay timer for process value alarm.
- Mean value processing.
- Rate-of-change calculation.
- Two values for each rate-of-change alarm input.
- Zero/span adjustment capability during operation.
- Disconnection detection.
- Maximum or minimum process value can be specified for when a disconnection is detected.

Model Information

| Unit classification | Model number | Inputs | Temperature sensor types |
|----------------------------|---------------------|---------------|---|
| CS-series Special I/O Unit | CS1W-PTS02 | 4 | Platinum resistance thermometer Pt100 (JIS, IEC) or JPt100. |

Block Diagram (Order of Processing)

The processing for the four inputs is as shown in the following diagram.

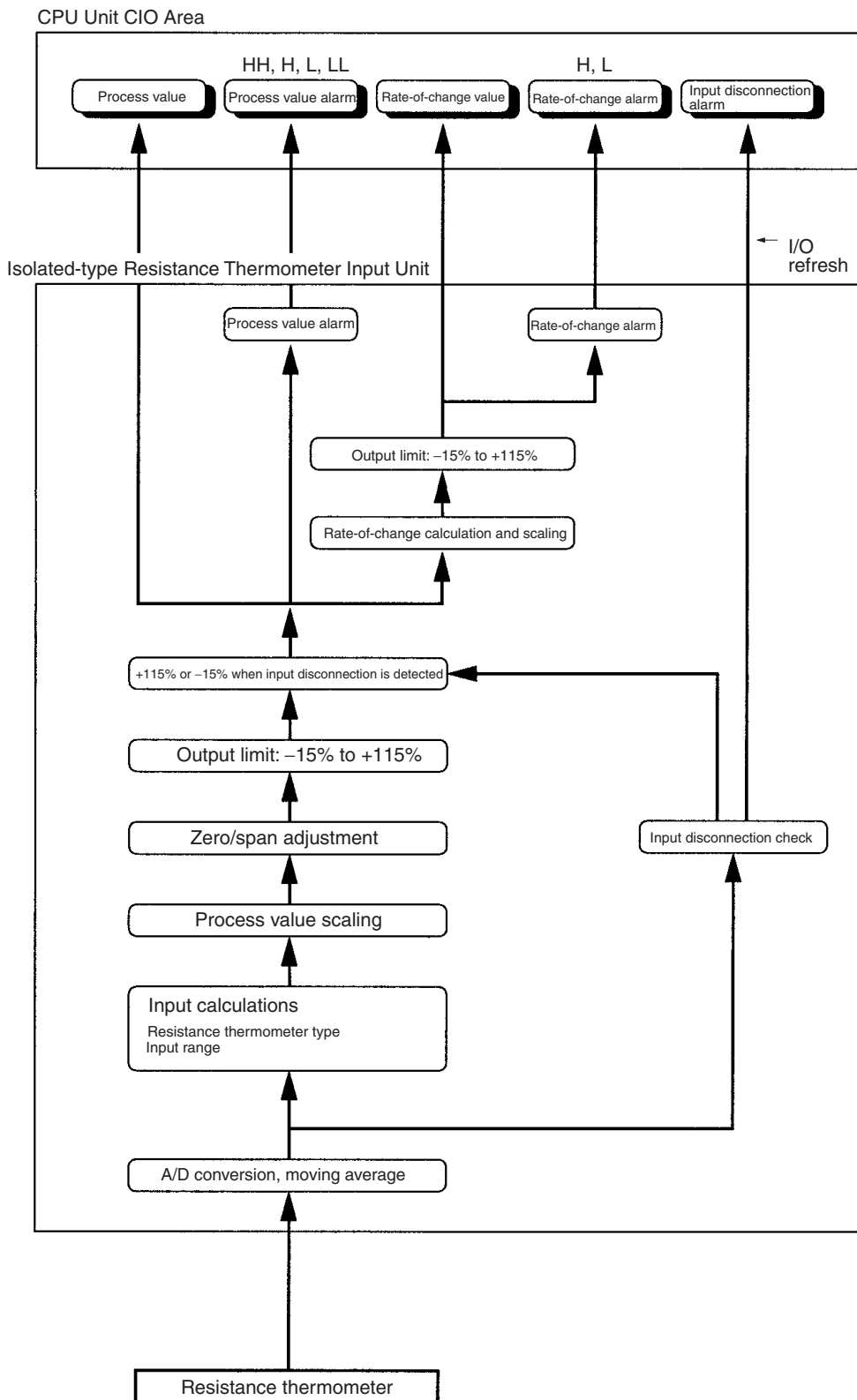

Specifications

| Item | | Specifications |
|---------------------------------------|--|---|
| Model | | CS1W-PTS02 |
| Applicable PLC | | CS Series |
| Unit classification | | CS-series Special I/O Unit |
| Mounting position | | CS-series CPU Rack or CS-series Expansion Rack (Cannot be mounted to C200H Expansion I/O Rack or SYSMAC BUS Remote I/O Slave Rack.) |
| Maximum number of Units | | 80 (within the allowable current consumption and power consumption range) |
| Unit numbers | | 00 to 95 (Cannot duplicate Special I/O Unit numbers.) |
| Areas for data exchange with CPU Unit | Special I/O Unit Area | 10 words/Unit Resistance Thermometer Input Unit to CPU Unit: All process values, process value alarms (LL, L, H, HH), rate-of-change values, rate-of-change alarms (L, H), disconnection alarms, cold junction sensor errors |
| | DM Area words allocated to Special I/O Units | 100 words/Unit CPU Unit to Resistance Thermometer Input Unit: Temperature sensor type, input range (user set), scaling of process value data to be stored in allocated words in CIO area, number of items for moving average, process value alarm setting (LL, L, H, HH), rate-of-change alarm setting (L, H), zero/span adjustment value, etc. |
| Number of temperature sensor inputs | | 4 |
| Temperature sensor types | | Pt100 (JIS, IEC) or JPt100 Note Sensor type, input range, and scaling to industrial units are separate for each of the 4 inputs. Note Sensor type, input range, and scaling to industrial units are set in the DM Area. |
| Input ranges | | The input range can be set within any of the measurable input ranges shown in Table 1 (below). Note Internally, inputs are processed in five ranges (refer to Table 2 below), so accuracy and resolution accord with these internal ranges. |
| Scaling in industrial units | | Example: Sensor type: Pt100; input range: 0 to 500°C; industrial unit scaling: 0.0 to 500°C. DM Area settings are as follows: Sensor type: 0 (0000 hex) Input signal maximum: 5000 (1388 hex) Input signal minimum: 0 (0000 hex) Industrial unit maximum value stored: 500 (01F4 hex) Industrial unit minimum value stored: 0 (0000 hex) |
| Data storage in the CIO Area | | Data to be stored in the allocated words in the CIO area must be scaled (individually for each of 4 inputs, with the minimum and maximum values set). Data can be stored at 0% to 100%. The value derived from carrying out the following processing in order of the actual process data in the input range is stored in four digits hexadecimal (binary values) in the allocated words in the CIO Area. 1) Mean value processing → 2) Scaling → 3) Zero/span adjustment → 4) Output limits |
| Accuracy (25°C) | | The greater of the following: ±0.1% (of internal range full span) or 0.1°C As shown in the following equation, the accuracy depends on the ratio of the selected internal range (0 to 4) span to the set input range span. $\text{Accuracy} = \pm 0.1\% \times \frac{\text{Internal range span}}{\text{Set input range span}} \text{ or } 0.1^\circ\text{C, whichever is greater.}$ |
| Temperature coefficient | | ±0.015% /°C, for any of internal range numbers 0 to 4. |
| Resolution | | 1/4,096 (of internal range full span) As shown in the following equation, the resolution depends on the ratio of the selected internal range (0 to 4) span to the set input range span. $\text{Resolution} = \frac{1}{4096} \times \frac{\text{Internal range span}}{\text{Set input range span}}$ |
| Sensing method | | 3-wire method |
| Allowable lead wire resistance | | 20 Ω max. per wire |

| Item | | Specifications |
|--|--------------------------------------|--|
| Input detection current | | 0.25 mA |
| Warmup time | | 10 min |
| Response time | | 0.5 s (travel time from input 0% to 90%, for step input) |
| Conversion period | | 100 ms/4 inputs |
| Maximum time to store data in CPU Unit | | Conversion period + one CPU Unit cycle |
| Disconnection detection | | Detects disconnections at each input and turns ON the Disconnection Detection Flag. Hardware detection time: Approx. 1 s The process value overrange direction for when a disconnection occurs can be specified. (High: 115% of set input range; low: -15% of set input range) |
| Function | Mean value processing (input filter) | Calculates the moving average for the specified number of process values (1 to 16), and stores that value in the CIO Area as the process value. |
| | Process value alarm | Process value 4-point alarm (HH, H, LL, L), alarm hysteresis, and ON-delay timer (0 to 60 s) are available. |
| | Rate-of-change calculation | Calculates the amount of change per comparison time interval (1 to 16 s). |
| | Rate-of-change alarm | Rate-of-change 2-point alarm (H, L), alarm hysteresis (shared with process value alarm), and ON-delay timer (0 to 60 s, shared with process value alarm) are available. |
| Isolation | | Between temperature inputs and between input terminals and PLC signals: Isolation by transformer |
| Insulation resistance | | 20 MΩ (at 500 V DC) between inputs |
| Dielectric strength | | Between inputs: 1,000 V AC, at 50/60 Hz, for 1 min, leakage current 10 mA max. |
| External connections | | Terminal block (detachable) |
| Unit number settings | | Set by rotary switches on front panel, from 0 to 95. |
| Indicators | | Three LED indicators on front panel (for normal operation, errors detected at the Resistance Thermometer Input Unit, and errors related to the CPU Unit). |
| Front panel connector | | Sensor input connector terminal block (detachable) |
| Effect on CPU Unit cycle time | | 0.3 ms |
| Current consumption | | 5 V DC at 150 mA max., 26 V DC at 150 mA max. |
| Dimensions | | 35 × 130 × 126 mm (W × H × D) Note The height including the Backplane is 145 mm. |
| Weight | | 450 g max. |
| Standard accessories | | None |

Sensor Type and Input Range

The resistance thermometer type and input range are set in the allocated words in the DM Area for every four inputs. The input range can be set anywhere within the measurable input ranges shown in Table 1.

Table 1: Measurable Input Ranges

| Sensor type | DM Area setting | Measurable input range (See note.) |
|-------------|-----------------|------------------------------------|
| Pt100 | 0 | -200 to 850°C |
| JPt100 | 1 | -200 to 500°C |

Note Set the input range in the DM Area within this range.

Internally inputs are processed in five progressive ranges (numbers 0 to 4), as shown in the following table.

Table 2: Internal Ranges

| Internal range number | Temperature range | Span |
|-----------------------|-------------------|---------|
| 0 | -200 to 850°C | 1,050°C |
| 1 | -200 to 438°C | 638°C |
| 2 | -200 to 211°C | 411°C |

| Internal range number | Temperature range | Span |
|-----------------------|-------------------|-------|
| 3 | -100 to 104°C | 204°C |
| 4 | -51 to 52°C | 103°C |

Therefore, the accuracy and resolution are determined by the ratio of the selected internal range (0 to 4) span to the set input range span. For the internal range, a larger number is selected when both the minimum and maximum values of the range fall within that next range.

For example, suppose that the sensor type is Pt100 and the set input range is -100 to 400°C. Since both the minimum and maximum values fall within the limits for internal range No. 1 (-200 to 438°C), that range will be selected.

Note With Resistance Thermometer Input Units, process values can be scaled (e.g., 0% to 100%) in industrial units for the set input range. It is possible to set the process value scaling higher than the resolution, but it will cause the values to be unstable.

DM Area Allocations

$$m = D20000 + \text{unit number} \times 100 \text{ (unit number: 0 to 95)}$$

| DM Area address | | | | Data range | | Default | Data contents |
|--|-------------|-------------|-------------|-----------------|------------------------------------|------------------|--|
| Input No. 1 | Input No. 2 | Input No. 3 | Input No. 4 | Decimal | Hexadecimal | | |
| m | | | | 12345, 0 | 3039, 0000 hex | 0000 hex | Default block read command Specifies the direction of data transfer when the PLC is turned ON or the Unit is restarted for DM words m+2 to m+93. <ul style="list-style-type: none"> 12345 (3039 hex): The data in words m+2 to m+93 is transferred from the Resistance Thermometer Input Unit to the CPU Unit. When the transfer is completed, the value will become 0000 hex. Other than 12345 (3039 hex) (such as 0000 hex): The data in the allocated words of DM Area is transferred from the CPU Unit to the Resistance Thermometer Input Unit. |
| Setting Group 1 (continuously refreshed area): Parameters that are continuously refreshed during PLC operation (regardless of the CPU Unit's operation mode) | | | | | | | |
| | | | | | | | Process value alarm settings |
| m + 2 | m + 10 | m + 18 | m + 26 | -32768 to 32767 | 8000 to FFFF hex, 0000 to 7FFF hex | 4200 (1068 hex) | Process value HH (high high limit) alarm setting (Set at process value scaling value.) |
| m + 3 | m + 11 | m + 19 | m + 27 | -32768 to 32767 | 8000 to FFFF hex, 0000 to 7FFF hex | 4000 (0FA0 hex) | Process value H (high limit) alarm setting (Set at process value scaling value.) |
| m + 4 | m + 12 | m + 20 | m + 28 | -32768 to 32767 | 8000 to FFFF hex, 0000 to 7FFF hex | 0 (0000 hex) | Process value L (low limit) alarm setting (Set at process value scaling value.) |
| m + 5 | m + 13 | m + 21 | m + 29 | -32768 to 32767 | 8000 to FFFF hex, 0000 to 7FFF hex | -200 (FF38 hex) | Process value LL (low low limit) alarm setting (Set at process value scaling value.) |
| | | | | | | | Rate-of-change value alarm settings |
| m + 6 | m + 14 | m + 22 | m + 30 | -32768 to 32767 | 8000 to FFFF hex, 0000 to 7FFF hex | 4000 (0FA0 hex) | Rate-of-change value H (high limit) alarm setting (Set at rate-of-change scaling value.) |
| m + 7 | m + 15 | m + 23 | m + 31 | -32768 to 32767 | 8000 to FFFF hex, 0000 to 7FFF hex | 0 (0000 hex) | Rate-of-change value L (low limit) alarm setting (Set at rate-of-change scaling value.) |
| | | | | | | | Zero/span adjustment |
| m + 8 | m + 16 | m + 24 | m + 32 | 0 to 32000 | 0000 to 7D00 hex | 10000 (2710 hex) | Gain for span adjustment (set value x 0.0001) |
| m + 9 | m + 17 | m + 25 | m + 33 | -32000 to 32000 | 8300 to FFFF hex, 0000 to 7D00 hex | 0 (0000 hex) | Zero adjustment value (Set at process value scaling value.) |
| Setting Group 2 (initial settings area): Parameters that are transferred one time from the CPU Unit to the Resistance Thermometer Input Unit if word m contains other than 12345 when the PLC is turned ON or the Resistance Thermometer Input Unit is restarted. | | | | | | | |
| m + 34 | m + 49 | m + 64 | m + 79 | 0, 1 | 0000 to 0001 hex | 0 (0000 hex) | Sensor type 0: Pt100; 1: JPt100 |
| | | | | | | | Process value input range settings |

| DM Area address | | | | Data range | | Default | Data contents |
|---------------------------------------|-------------|-------------|-------------|-----------------|------------------------------------|------------------|--|
| Input No. 1 | Input No. 2 | Input No. 3 | Input No. 4 | Decimal | Hexadecimal | | |
| m + 35 | m + 50 | m + 65 | m + 80 | -32000 to 32000 | 8300 to FFFF hex, 0000 to 7D00 hex | 4000 (0FA0 hex) | Maximum input signal value (set value x 0.1°C/°F) |
| m + 36 | m + 51 | m + 66 | m + 81 | -32000 to 32000 | 8300 to FFFF hex, 0000 to 7D00 hex | 0 (0000 hex) | Minimum input signal value (set value x 0.1°C/°F) |
| m + 37 | m + 52 | m + 67 | m + 82 | 0, 1 | 0000, 0001 hex | 0 (0000 hex) | Unit 0: °C, 1: °F |
| m + 38 | m + 53 | m + 68 | m + 83 | 0, 1 | 0000, 0001 hex | 0 (0000 hex) | Process value overrange direction at time of input disconnection 0: High; 1: Low |
| Process value scaling | | | | | | | |
| m + 39 | m + 54 | m + 69 | m + 84 | -32000 to 32000 | 8300 to FFFF hex, 0000 to 7D00 hex | 4000 (0FA0 hex) | Value stored for maximum value in range (span) |
| m + 40 | m + 55 | m + 70 | m + 85 | -32000 to 32000 | 8300 to FFFF hex, 0000 to 7D00 hex | 0 (0000 hex) | Value stored for minimum value in range (zero) |
| Alarm supplementary functions | | | | | | | |
| m + 41 | m + 56 | m + 71 | m + 86 | 0 to 32000 | 0000 to 7D00 hex | 40 (0028 hex) | Alarm hysteresis (Set at process value scaling value. Shared with process value alarm and rate-of-change alarm.) |
| m + 42 | m + 57 | m + 72 | m + 87 | 0 to 60 | 0000 to 003C hex | 0 (0000 hex) | Alarm ON-delay time (Unit: s) (Shared with process value alarm and rate-of-change alarm.) |
| Rate-of-change function | | | | | | | |
| m + 43 | m + 58 | m + 73 | m + 88 | -32000 to 32000 | 8300 to FFFF hex, 0000 to 7D00 hex | 4000 (0FA0 hex) | Rate-of-change range setting Maximum rate-of-change value (Process value industrial unit; comparison time interval) |
| m + 44 | m + 59 | m + 74 | m + 89 | -32000 to 32000 | 8300 to FFFF hex, 0000 to 7D00 hex | -4000 (F060 hex) | |
| m + 45 | m + 60 | m + 75 | m + 90 | 1 to 16 | 0001 to 0010 hex | 1 (0001 hex) | Rate-of-change comparison time interval (Unit: s) |
| m + 46 | m + 61 | m + 76 | m + 91 | -32000 to 32000 | 8300 to FFFF hex, 0000 to 7D00 hex | 4000 (0FA0 hex) | Rate-of-change value scaling Value stored for maximum value in range |
| m + 47 | m + 62 | m + 77 | m + 92 | -32000 to 32000 | 8300 to FFFF hex, 0000 to 7D00 hex | 0 (0000 hex) | |
| Mean value processing function | | | | | | | |
| m + 48 | m + 63 | m + 78 | m + 93 | 1 to 16 | 0001 to 0010 hex | 4 (0004 hex) | Number of process values for calculating moving average for mean value processing |
| Storage parameter | | | | | | | |
| m + 94 | m + 95 | m + 96 | m + 97 | 0 to 93 | 0000 to 005D hex | 0 (0000 hex) | Address of Data Range Error (See note.) |

Note The ERC indicator on the Unit's front panel will light if an out-of-range setting is made in either Setting Group 1 or 2. The offset from word m to the first word containing the out-of-range error will be stored as the Address of Data Range Error in the DM Area in four digits hexadecimal. For more information, refer to *1-6 Error Processing*.

CIO Area Allocations

n = 2000 + unit number × 10 (unit number: 0 to 95)

| Direction | Word | Bit | Name | | Data range | Contents |
|---|------|-----|-------------|--|------------|------------------------------|
| Resistance Thermometer Input Unit to CPU Unit | n | 00 | Input No. 1 | Process value LL (low low limit) alarm | 0, 1 | 0: Process value > Set value |
| | | 01 | | Process value L (low limit) alarm | 0, 1 | 1: Process value ≤ Set value |
| | | 02 | | Process value H (high limit) alarm | 0, 1 | 0: Process value < Set value |
| | | 03 | | Process value HH (high high limit) alarm | 0, 1 | 1: Process value ≥ Set value |
| | | 04 | Input No. 2 | Process value LL (low low limit) alarm | 0, 1 | Same as for input No. 1. |
| | | 05 | | Process value L (low limit) alarm | 0, 1 | |
| | | 06 | | Process value H (high limit) alarm | 0, 1 | |
| | | 07 | | Process value HH (high high limit) alarm | 0, 1 | |
| | | 08 | Input No. 3 | Process value LL (low low limit) alarm | 0, 1 | Same as for input No. 1. |
| | | 09 | | Process value L (low limit) alarm | 0, 1 | |
| | | 10 | | Process value H (high limit) alarm | 0, 1 | |
| | | 11 | | Process value HH (high high limit) alarm | 0, 1 | |
| | | 12 | Input No. 4 | Process value LL (low low limit) alarm | 0, 1 | Same as for input No. 1. |
| | | 13 | | Process value L (low limit) alarm | 0, 1 | |
| | | 14 | | Process value H (high limit) alarm | 0, 1 | |
| | | 15 | | Process value HH (high high limit) alarm | 0, 1 | |

| Direction | Word | Bit | Name | | Data range | Contents | |
|---|-------|-------------|----------------------------------|---|---|--|--|
| Resistance Thermometer Input Unit to CPU Unit | n + 1 | 00 to 15 | Input No. 1 process value | | -32768 to 32767 (8000 to FFFF hex, 0000 to 7FFF hex) | The present process value is stored according to the scaling set in the allocated words of the DM Area. | |
| | n + 2 | 00 to 15 | Input No. 2 process value | | -32768 to 32767 (8000 to FFFF hex, 0000 to 7FFF hex) | | |
| | n + 3 | 00 to 15 | Input No. 3 process value | | -32768 to 32767 (8000 to FFFF hex, 0000 to 7FFF hex) | | |
| | n + 4 | 00 to 15 | Input No. 4 process value | | -32768 to 32767 (8000 to FFFF hex, 0000 to 7FFF hex) | | |
| | n + 5 | 00 to 15 | Input No. 1 rate-of-change value | | -32768 to 32767 (8000 to FFFF hex, 0000 to 7FFF hex) | The process value rate of change is stored according to the scaling set in the allocated words of the DM Area. | |
| | n + 6 | 00 to 15 | Input No. 2 rate-of-change value | | -32768 to 32767 (8000 to FFFF hex, 0000 to 7FFF hex) | | |
| | n + 7 | 00 to 15 | Input No. 3 rate-of-change value | | -32768 to 32767 (8000 to FFFF hex, 0000 to 7FFF hex) | | |
| | n + 8 | 00 to 15 | Input No. 4 rate-of-change value | | -32768 to 32767 (8000 to FFFF hex, 0000 to 7FFF hex) | | |
| | n + 9 | 00 | 00 | Input No. 1 | Rate-of-change value L (low limit) alarm | 0, 1 | 0: Rate-of-change value > Set value 1: Rate-of-change value ≤ Set value |
| | | | | | Rate-of-change value H (high limit) alarm | 0, 1 | 0: Rate-of-change value < Set value 1: Rate-of-change value ≥ Set value |
| | | 02 | 01 | Input No. 2 | Rate-of-change value L (low limit) alarm | 0, 1 | Same as for input No. 1. |
| | | | | | Rate-of-change value H (high limit) alarm | 0, 1 | |
| | | 04 | 03 | Input No. 3 | Rate-of-change value L (low limit) alarm | 0, 1 | Same as for input No. 1. |
| | | | | | Rate-of-change value H (high limit) alarm | 0, 1 | |
| 06 | | 05 | Input No. 4 | Rate-of-change value L (low limit) alarm | 0, 1 | Same as for input No. 1. | |
| | | | | Rate-of-change value H (high limit) alarm | 0, 1 | | |
| 08 | | 06 | Input No. 1 | input disconnection | 0, 1 | 0: Normal 1: Disconnection | |
| 09 | | 07 | Input No. 2 | input disconnection | 0, 1 | Same as for input No. 1. | |
| 10 | 08 | Input No. 3 | input disconnection | 0, 1 | Same as for input No. 1. | | |
| 11 | 09 | Input No. 4 | input disconnection | 0, 1 | Same as for input No. 1. | | |

Terminal Connection Diagram

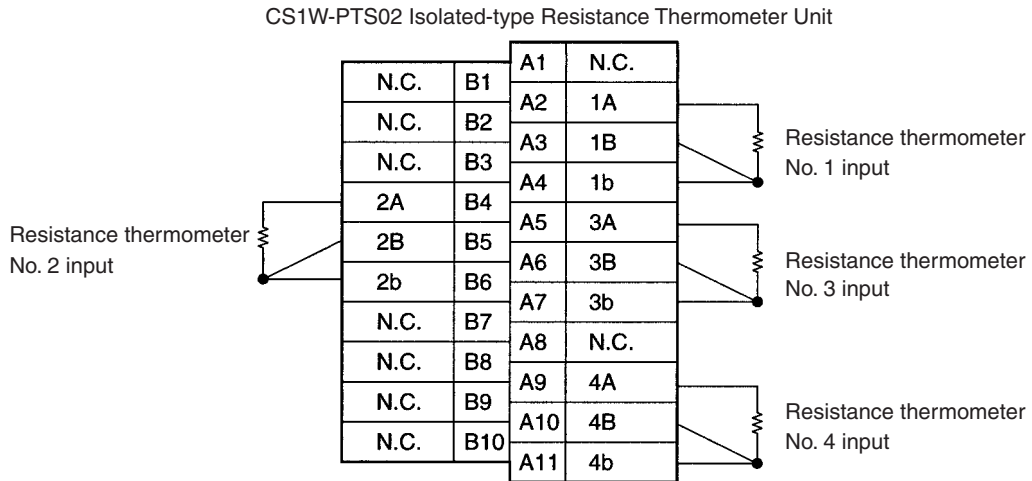

- Note**
1. Wire the same length to A, B, and b, so that the impedance will be the same. In particular, do not short circuit between B and b at the terminal block.
 2. For unused input terminals, short-circuit between A–B and B–b (e.g., A2–A3 and A3–A4 for input No. 1) of the resistance thermometer inputs with the lead wire.

Terminal Block Diagram

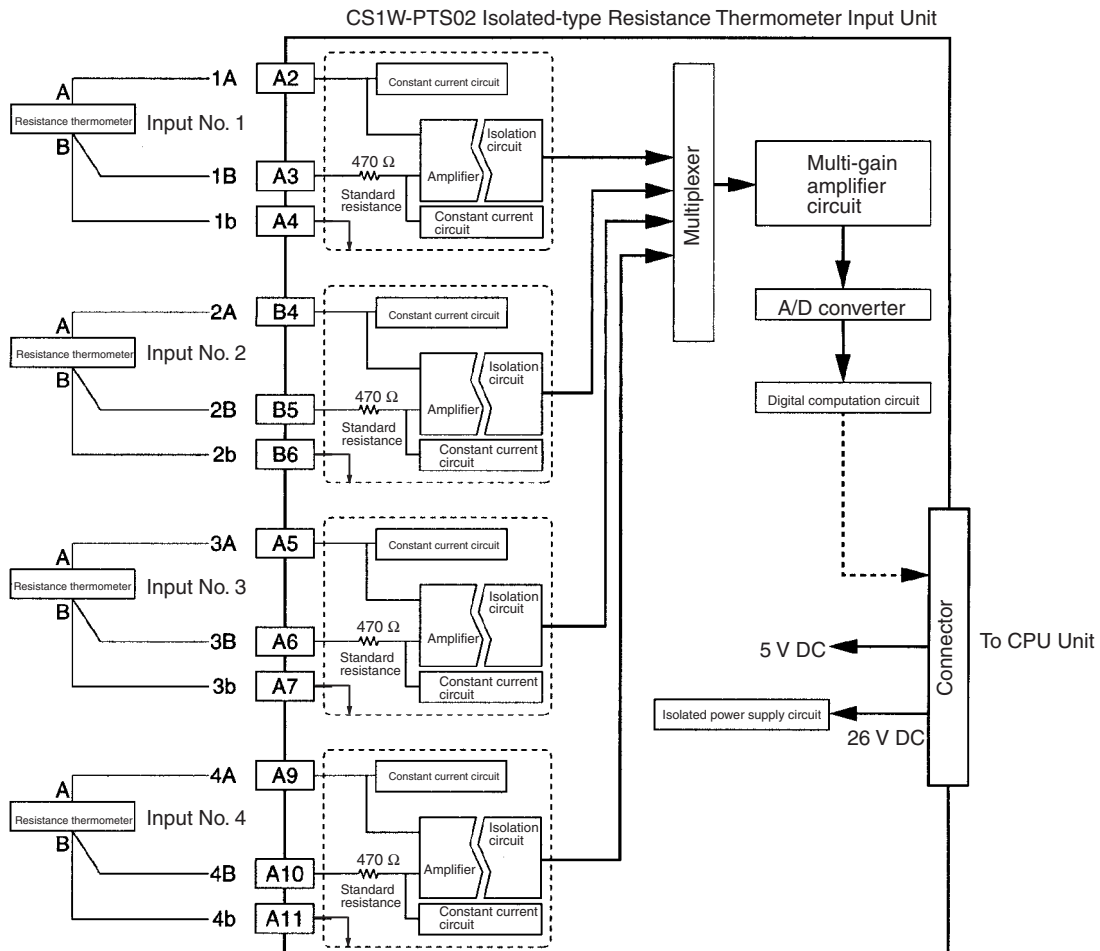

Error Processing

Conversion Data Does Not Change.

| Probable cause | Remedy |
|--|--|
| The gain for span adjustment is set to 0. | Set the gain for span adjustment to a value other than 0. |
| The minimum and maximum values for process value scaling are either the same or are set extremely low. | Set the minimum and maximum values correctly. |
| The sensor type, input range, or process value scaling is not set correctly. | Check and correct the settings. |
| An input device is malfunctioning, input wiring is faulty, or wiring is disconnected. | Check whether the input voltage or current has changed. Check for faulty or disconnected wiring. Check whether a wiring disconnection has been detected in the I/O Area. |

Values are Not Converted as Intended.

| Probable cause | Remedy |
|--|--|
| The sensor type, input range, or process value scaling is not set correctly. | Check and correct the settings. |
| The zero/span adjustment data is incorrect. | Check and correct the zero/span adjustment settings. |
| The resistance thermometer input wiring is faulty. | Correct the input wiring. |

Converted Values are Unstable.

| Probable cause | Remedy |
|--|---|
| Input signals are being affected by external noise. | Change the connection paths of the input signal lines. (Separate them from sources of noise or use shielded cable.) |
| | Increase the number of values for calculating the moving average in mean value processing. |
| The process value scaling value is greater than the Unit's resolution. | Reduce the process value scaling value. |
| The input signal range setting is too small. | Match the input signal range to the internal ranges. |

2-6 CS1W-PTS03 Isolated-type Resistance Thermometer Input Unit (Ni508.4)

Overview

The CS1W-PTS03 Isolated-type Resistance Thermometer Input Unit provides four direct Ni thermometer inputs, and sends the data to the CPU Unit each cycle. All inputs are isolated.

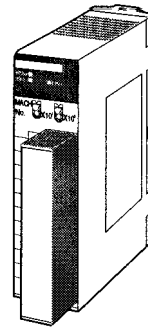

CS1W-PTS03

System Configuration

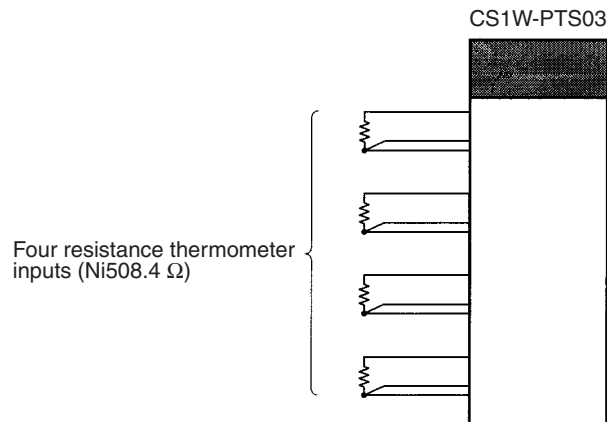

Features

- Up to four Ni resistance thermometers can be connected for each Unit (with four separate input ranges).
- Temperature sensor values are sent to the CPU Unit in four digits hexadecimal.
- Variable input range setting.
- Four values for each process value alarm input.
- ON-delay timer for process value alarm.
- Mean value processing.
- Rate-of-change calculation.
- Two values for each rate-of-change alarm input.
- Zero/span adjustment capability during operation.
- Disconnection detection.
- Maximum or minimum process value can be specified for when a disconnection is detected.

Model Information

| Unit classification | Model number | Inputs | Temperature sensor types |
|----------------------------|--------------|--------|--------------------------------|
| CS-series Special I/O Unit | CS1W-PTS03 | 4 | Resistance thermometer Ni508.4 |

Block Diagram (Order of Processing)

The processing for the four inputs is as shown in the following diagram.

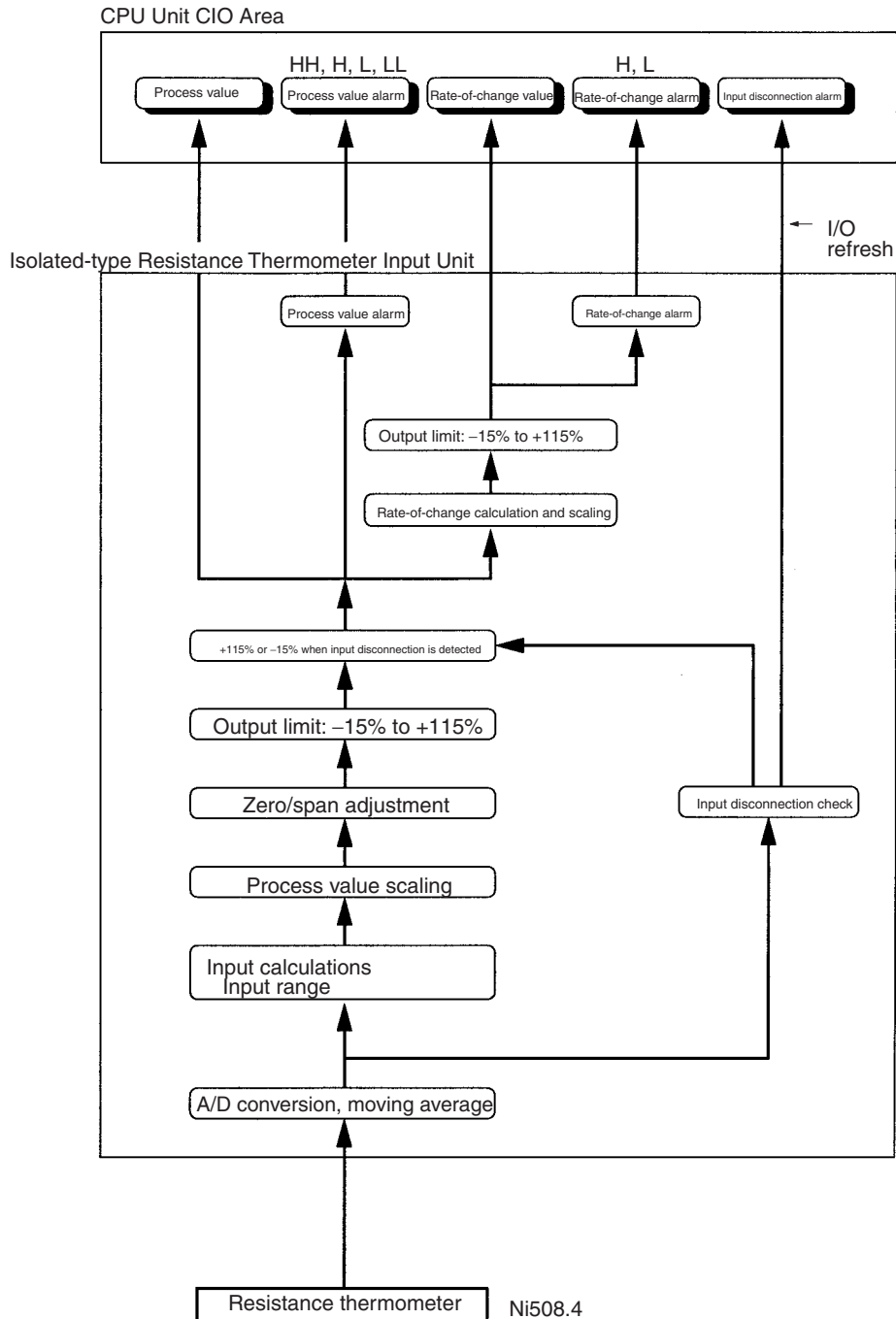

Specifications

| Item | | Specifications |
|---------------------------------------|--|--|
| Model | | CS1W-PTS03 |
| Applicable PLC | | CS Series |
| Unit classification | | CS-series Special I/O Unit |
| Mounting position | | CS-series CPU Rack or CS-series Expansion Rack (Cannot be mounted to C200H Expansion I/O Rack or SYSMAC BUS Remote I/O Slave Rack.) |
| Maximum number of Units | | 80 (within the allowable current consumption and power consumption range) |
| Unit numbers | | 00 to 95 (Cannot duplicate Special I/O Unit numbers.) |
| Areas for data exchange with CPU Unit | Special I/O Unit Area | 10 words/Unit Resistance Thermometer Input Unit to CPU Unit: All process values, process value alarms (LL, L, H, HH), rate-of-change values, rate-of-change alarms (L, H), disconnection alarms |
| | DM Area words allocated to Special I/O Units | 100 words/Unit CPU Unit to Resistance Thermometer Input Unit: Temperature sensor type, input range (user set), scaling of process value data to be stored in allocated words in CIO area, number of items for moving average, process value alarm setting (LL, L, H, HH), rate-of-change alarm setting (L, H), zero/span adjustment value, etc. |
| Number of temperature sensor inputs | | 4 |
| Temperature sensor types | | Ni508.4 Input range and scaling to industrial units are separate for each of the 4 inputs. Note Sensor type, input range, and scaling to industrial units are set in the DM Area. |
| Input ranges | | The input range can be set within a range of -50 to 150°C (variable setting). Note Internally, inputs are processed in the above range (refer to Table 2 below), so accuracy and resolution accord with this internal range. |
| Scaling in industrial units | | Data to be stored in the allocated words in the CIO area must be scaled (with the minimum and maximum values set). Data can be stored at 0% to 100%. Example: Input range: -50 to 100°C; industrial unit scaling: -50.0 to 100.0°C. DM Area settings are as follows: Input signal maximum: 1000 (03E8 hex) Input signal minimum: -500 (FE0C hex) Industrial unit maximum value stored: 1000 (03E8 hex) Industrial unit minimum value stored: -500 (FE0C hex) |
| Data storage in the CIO Area | | The value derived from carrying out the following processing in order of the actual process data in the input range is stored in four digits hexadecimal (binary values) in the allocated words in the CIO Area. 1) Mean value processing → 2) Scaling → 3) Zero/span adjustment → 4) Output limits |
| Accuracy (25°C) | | The greater of the following: ±0.2% (of internal range full span) or 0.2°C As shown in the following equation, the accuracy depends on the ratio of the selected internal range (0 to 4) span to the set input range span. $\text{Accuracy} = \pm 0.1\% \times \frac{\text{Internal range span}}{\text{Set input range span}} \text{ or } 0.2^\circ\text{C, whichever is greater.}$ |
| Temperature coefficient | | ±0.015% /°C, for any of internal range numbers 0 to 4. |
| Resolution | | 1/4,096 (of internal range full span) As shown in the following equation, the resolution depends on the ratio of the internal range span to the set input range span. $\text{Resolution} = \frac{1}{4096} \times \frac{\text{Internal range span}}{\text{Set input range span}}$ |
| Sensing method | | 3-wire method |
| Allowable lead wire resistance | | 20 Ω max. per wire |
| Input detection current | | 0.25 mA |
| Warmup time | | 10 min |

| Item | | Specifications |
|--|--------------------------------------|---|
| Response time | | 0.5 s (travel time from input 0% to 90%, for step input) |
| Conversion period | | 100 ms/4 inputs |
| Maximum time to store data in CPU Unit | | Conversion period + one CPU Unit cycle |
| Disconnection detection | | Detects disconnections at each input and turns ON the Disconnection Detection Flag. Hardware detection time: Approx. 1 s The process value high/low direction for when a disconnection occurs can be specified. (High: 115% of set input range; low: -15% of set input range) |
| Function | Mean value processing (input filter) | Calculates the moving average for the specified number of process values (1 to 16), and stores that value in the CIO Area as the process value. |
| | Process value alarm | Process value 4-point alarm (HH, H, LL, L), alarm hysteresis, and ON-delay timer (0 to 60 s) are available. |
| | Rate-of-change calculation | Calculates the amount of change per comparison time interval (1 to 16 s). |
| | Rate-of-change alarm | Rate-of-change 2-point alarm (H, L), alarm hysteresis (shared with process value alarm), and ON-delay timer (0 to 60 s, shared with process value alarm) are available. |
| Isolation | | Between temperature inputs and between input terminals and PLC signals: Isolation by transformer |
| Insulation resistance | | 20 MΩ (at 500 V DC) between inputs |
| Dielectric strength | | Between inputs: 1,000 V AC, at 50/60 Hz, for 1 min, leakage current 10 mA max. |
| External connections | | Terminal block (detachable) |
| Unit number settings | | Set by rotary switches on front panel, from 0 to 95. |
| Indicators | | Three LED indicators on front panel (for normal operation, errors detected at the Resistance Thermometer Input Unit, and errors related to the CPU Unit). |
| Front panel connector | | Sensor input connector terminal block (detachable) |
| Effect on CPU Unit cycle time | | 0.3 ms |
| Current consumption | | 5 V DC at 150 mA max., 26 V DC at 150 mA max. |
| Dimensions | | 35 × 130 × 126 mm (W × H × D) Note The height including the Backplane is 145 mm. |
| Weight | | 450 g max. |
| Standard accessories | | None |

Sensor Type and Input Range

The input range is set in the allocated words in the DM Area for every four inputs. It can be set anywhere within the measurable input range shown in Table 1.

Measurable Input Range

| Sensor type | Measurable Input range (See note.) |
|-------------|------------------------------------|
| Ni508.4 | -50 to 150°C |

Note Set the input range in the DM Area within this range.

Even if the input range is set more narrowly than the range of -50 to 150°C, internally inputs will be processed according to the internal range shown in the following table.

Internal range

| Internal range temperatures | Internal range span |
|-----------------------------|---------------------|
| -50 to 150°C | 200°C |

Therefore, the accuracy and resolution are determined by the ratio of the internal range span to the set input range span.

Example: Even if the set input range is -50 to 100°C, internally inputs will be processed according to the internal range of -50 to 150°C.

Note With Resistance Thermometer Units (Ni508.4), process values can be scaled (e.g., 0% to 100%) in industrial units for the set input range. Generally, however, set the same values for process value scaling in industrial units as for the set input range. It is possible to set the process value scaling higher than the resolution, but it will cause the values to be unstable.

DM Area Allocations

$m = D20000 + \text{unit number} \times 100$ (unit number: 0 to 95)

| DM Area address | | | | Data range | | Default | Data contents |
|--|-------------|-------------|-------------|-----------------|------------------------------------|------------------|--|
| Input No. 1 | Input No. 2 | Input No. 3 | Input No. 4 | Decimal | Hexadecimal | | |
| m | | | | 12345, 0 | 3039, 0000 hex | 0000 hex | Default block read command Specifies the direction of data transfer when the PLC is turned ON or the Unit is restarted for DM words m+2 to m+93. <ul style="list-style-type: none"> 12345 (3039 hex): The data in words m+2 to m+93 is transferred from the Resistance Thermometer Input Unit to the CPU Unit. When the transfer is completed, the value will become 0000 hex. Other than 12345 (such as 0000 hex): The data in the allocated words of DM Area is transferred from the CPU Unit to the Resistance Thermometer Input Unit. |
| Setting Group 1 (continuously refreshed area): Parameters that are continuously refreshed during PLC operation (regardless of the CPU Unit's operation mode) | | | | | | | |
| | | | | | | | Process value alarm settings |
| m + 2 | m + 10 | m + 18 | m + 26 | -32768 to 32767 | 8000 to FFFF hex, 0000 to 7FFF hex | 4200 (1068 hex) | Process value HH (high high limit) alarm setting (Set at process value scaling value.) |
| m + 3 | m + 11 | m + 19 | m + 27 | -32768 to 32767 | 8000 to FFFF hex, 0000 to 7FFF hex | 4000 (0FA0 hex) | Process value H (high limit) alarm setting (Set at process value scaling value.) |
| m + 4 | m + 12 | m + 20 | m + 28 | -32768 to 32767 | 8000 to FFFF hex, 0000 to 7FFF hex | 0 (0000 hex) | Process value L (low limit) alarm setting (Set at process value scaling value.) |
| m + 5 | m + 13 | m + 21 | m + 29 | -32768 to 32767 | 8000 to FFFF hex, 0000 to 7FFF hex | -200 (FF38 hex) | Process value LL (low low limit) alarm setting (Set at process value scaling value.) |
| | | | | | | | Rate-of-change value alarm settings |
| m + 6 | m + 14 | m + 22 | m + 30 | -32768 to 32767 | 8000 to FFFF hex, 0000 to 7FFF hex | 4000 (0FA0 hex) | Rate-of-change value H (high limit) alarm setting (Set at rate-of-change scaling value.) |
| m + 7 | m + 15 | m + 23 | m + 31 | -32768 to 32767 | 8000 to FFFF hex, 0000 to 7FFF hex | 0 (0000 hex) | Rate-of-change value L (low limit) alarm setting (Set at rate-of-change scaling value.) |
| | | | | | | | Zero/span adjustment |
| m + 8 | m + 16 | m + 24 | m + 32 | 0 to 32000 | 0000 to 7D00 hex | 10000 (2710 hex) | Gain for span adjustment (set value x 0.0001) |
| m + 9 | m + 17 | m + 25 | m + 33 | -32000 to 32000 | 8300 to FFFF hex, 0000 to 7D00 hex | 0 (0000 hex) | Zero adjustment value (Set at process value scaling value.) |
| Setting Group 2 (initial settings area): Parameters that are transferred one time from the CPU Unit to the Resistance Thermometer Input Unit if word m contains other than 12345 when the PLC is turned ON or the Resistance Thermometer Input Unit is restarted. | | | | | | | |
| m + 34 | m + 49 | m + 64 | m + 79 | 2 | 0002 hex | 2 (0002 hex) | Sensor type 2: Ni508.4 |
| | | | | | | | Process value input range settings |
| m + 35 | m + 50 | m + 65 | m + 80 | -32000 to 32000 | 8300 to FFFF hex, 0000 to 7D00 hex | 1000 (03E8 hex) | Maximum input signal value (set value x 0.1°C/°F) |
| m + 36 | m + 51 | m + 66 | m + 81 | -32000 to 32000 | 8300 to FFFF hex, 0000 to 7D00 hex | -500 (FE0CH hex) | Minimum input signal value (set value x 0.1°C/°F) |
| m + 37 | m + 52 | m + 67 | m + 82 | 0, 1 | 0000, 0001 hex | 0 (0000 hex) | Unit 0: °C, 1: °F |
| m + 38 | m + 53 | m + 68 | m + 83 | 0, 1 | 0000, 0001 hex | 0 (0000 hex) | Process value overrange direction at time of input disconnection 0: High; 1: Low |

| DM Area address | | | | Data range | | Default | Data contents | | |
|--------------------------|-------------|-------------|-------------|-----------------|------------------------------------|------------------|--|--|--|
| Input No. 1 | Input No. 2 | Input No. 3 | Input No. 4 | Decimal | Hexadecimal | | | | |
| | | | | | | | | Process value scaling | |
| m + 39 | m + 54 | m + 69 | m + 84 | -32000 to 32000 | 8300 to FFFF hex, 0000 to 7D00 hex | 4000 (0FA0 hex) | Value stored for maximum value in range (span) | | |
| m + 40 | m + 55 | m + 70 | m + 85 | -32000 to 32000 | 8300 to FFFF hex, 0000 to 7D00 hex | 0 (0000 hex) | Value stored for minimum value in range (zero) | | |
| | | | | | | | | Alarm supplementary functions | |
| m + 41 | m + 56 | m + 71 | m + 86 | 0 to 32000 | 0000 to 7D00 hex | 40 (0028 hex) | Alarm hysteresis (Set at process value scaling value. Shared with process value alarm and rate-of-change alarm.) | | |
| m + 42 | m + 57 | m + 72 | m + 87 | 0 to 60 | 0000 to 003C hex | 0 (0000 hex) | Alarm ON-delay time (Unit: s) (Shared with process value alarm and rate-of-change alarm.) | | |
| | | | | | | | | Rate-of-change function | |
| m + 43 | m + 58 | m + 73 | m + 88 | -32000 to 32000 | 8300 to FFFF hex, 0000 to 7D00 hex | 4000 (0FA0 hex) | Rate-of-change range setting | Maximum rate-of-change value (Process value industrial unit; comparison time interval) | |
| m + 44 | m + 59 | m + 74 | m + 89 | -32000 to 32000 | 8300 to FFFF hex, 0000 to 7D00 hex | -4000 (F060 hex) | | Minimum rate-of-change value (Process value industrial unit; comparison time interval) | |
| m + 45 | m + 60 | m + 75 | m + 90 | 1 to 16 | 0001 to 0010 hex | 1 (0001 hex) | Rate-of-change comparison time interval (Unit: s) | | |
| m + 46 | m + 61 | m + 76 | m + 91 | -32000 to 32000 | 8300 to FFFF hex, 0000 to 7D00 hex | 4000 (0FA0 hex) | Rate-of-change value scaling | Value stored for maximum value in range | |
| m + 47 | m + 62 | m + 77 | m + 92 | -32000 to 32000 | 8300 to FFFF hex, 0000 to 7D00 hex | 0 (0000 hex) | | Value stored for minimum value in range | |
| | | | | | | | | Mean value processing function | |
| m + 48 | m + 63 | m + 78 | m + 93 | 1 to 16 | 0001 to 0010 hex | 4 (0004 hex) | Number of process values for calculating moving average for mean value processing | | |
| Storage parameter | | | | | | | | | |
| m + 94 | m + 95 | m + 96 | m + 97 | 0 to 93 | 0000 to 005D hex | 0 (0000 hex) | Address of Data Range Error (See note.) | | |

Note The ERC indicator on the Unit's front panel will light if an out-of-range setting is made in either Setting Group 1 or 2. The offset from word m to the first word containing the out-of-range error will be stored as the Address of Data Range Error in the DM Area in four digits hexadecimal. For more information, refer to *1-6 Error Processing*.

CIO Area Allocations

n = 2000 + unit number × 10 (unit number: 0 to 95)

| Direction | Word | Bit | Name | | Data range | Contents |
|---|------|-----|-------------|--|------------|------------------------------|
| Resistance Thermometer Input Unit to CPU Unit | n | 00 | Input No. 1 | Process value LL (low low limit) alarm | 0, 1 | 0: Process value > Set value |
| | | 01 | | Process value L (low limit) alarm | 0, 1 | 1: Process value ≤ Set value |
| | | 02 | | Process value H (high limit) alarm | 0, 1 | 0: Process value < Set value |
| | | 03 | | Process value HH (high high limit) alarm | 0, 1 | 1: Process value ≥ Set value |
| | | 04 | Input No. 2 | Process value LL (low low limit) alarm | 0, 1 | Same as for input No. 1. |
| | | 05 | | Process value L (low limit) alarm | 0, 1 | |
| | | 06 | | Process value H (high limit) alarm | 0, 1 | |
| | | 07 | | Process value HH (high high limit) alarm | 0, 1 | |
| | | 08 | Input No. 3 | Process value LL (low low limit) alarm | 0, 1 | Same as for input No. 1. |
| | | 09 | | Process value L (low limit) alarm | 0, 1 | |
| | | 10 | | Process value H (high limit) alarm | 0, 1 | |
| | | 11 | | Process value HH (high high limit) alarm | 0, 1 | |
| | | 12 | Input No. 4 | Process value LL (low low limit) alarm | 0, 1 | Same as for input No. 1. |
| | | 13 | | Process value L (low limit) alarm | 0, 1 | |
| | | 14 | | Process value H (high limit) alarm | 0, 1 | |
| | | 15 | | Process value HH (high high limit) alarm | 0, 1 | |

| Direction | Word | Bit | Name | | Data range | Contents | |
|---|-------|-------------|----------------------------------|---|---|--|--|
| Resistance Thermometer Input Unit to CPU Unit | n + 1 | 00 to 15 | Input No. 1 process value | | -32768 to 32767 (8000 to FFFF hex, 0000 to 7FFF hex) | The present process value is stored according to the scaling set in the allocated words of the DM Area. | |
| | n + 2 | 00 to 15 | Input No. 2 process value | | -32768 to 32767 (8000 to FFFF hex, 0000 to 7FFF hex) | | |
| | n + 3 | 00 to 15 | Input No. 3 process value | | -32768 to 32767 (8000 to FFFF hex, 0000 to 7FFF hex) | | |
| | n + 4 | 00 to 15 | Input No. 4 process value | | -32768 to 32767 (8000 to FFFF hex, 0000 to 7FFF hex) | | |
| | n + 5 | 00 to 15 | Input No. 1 rate-of-change value | | -32768 to 32767 (8000 to FFFF hex, 0000 to 7FFF hex) | The process value rate of change is stored according to the scaling set in the allocated words of the DM Area. | |
| | n + 6 | 00 to 15 | Input No. 2 rate-of-change value | | -32768 to 32767 (8000 to FFFF hex, 0000 to 7FFF hex) | | |
| | n + 7 | 00 to 15 | Input No. 3 rate-of-change value | | -32768 to 32767 (8000 to FFFF hex, 0000 to 7FFF hex) | | |
| | n + 8 | 00 to 15 | Input No. 4 rate-of-change value | | -32768 to 32767 (8000 to FFFF hex, 0000 to 7FFF hex) | | |
| | n + 9 | 00 | 00 | Input No. 1 | Rate-of-change value L (low limit) alarm | 0, 1 | 0: Rate-of-change value > Set value 1: Rate-of-change value ≤ Set value |
| | | | | | Rate-of-change value H (high limit) alarm | 0, 1 | 0: Rate-of-change value < Set value 1: Rate-of-change value ≥ Set value |
| | | 02 | 01 | Input No. 2 | Rate-of-change value L (low limit) alarm | 0, 1 | Same as for input No. 1. |
| | | | | | Rate-of-change value H (high limit) alarm | 0, 1 | |
| | | 04 | 03 | Input No. 3 | Rate-of-change value L (low limit) alarm | 0, 1 | Same as for input No. 1. |
| | | | | | Rate-of-change value H (high limit) alarm | 0, 1 | |
| 06 | | 05 | Input No. 4 | Rate-of-change value L (low limit) alarm | 0, 1 | Same as for input No. 1. | |
| | | | | Rate-of-change value H (high limit) alarm | 0, 1 | | |
| 08 | | 06 | Input No. 1 | input disconnection | 0, 1 | 0: Normal 1: Disconnection | |
| 09 | | 07 | Input No. 2 | input disconnection | 0, 1 | Same as for input No. 1. | |
| 10 | 08 | Input No. 3 | input disconnection | 0, 1 | Same as for input No. 1. | | |
| 11 | 09 | Input No. 4 | input disconnection | 0, 1 | Same as for input No. 1. | | |

Terminal Connection Diagram

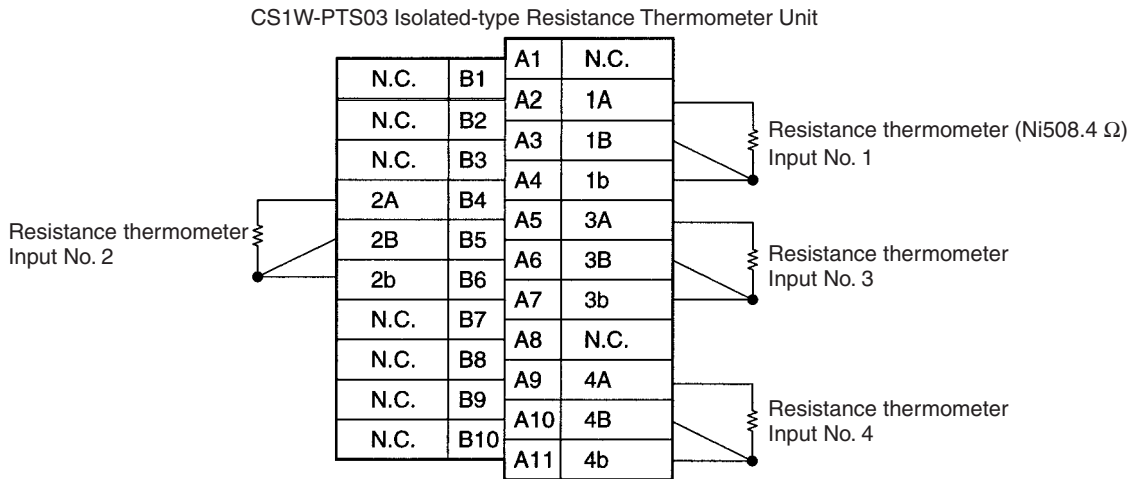

- Note**
1. Wire the same length to A, B, and b, so that the impedance will be the same. In particular, do not short circuit between B and b at the terminal block.
 2. For unused input terminals, short-circuit between A–B and B–b (e.g., A2–A3 and A3–A4 for input No. 1) of the resistance thermometer inputs with the lead wire.

Terminal Block Diagram

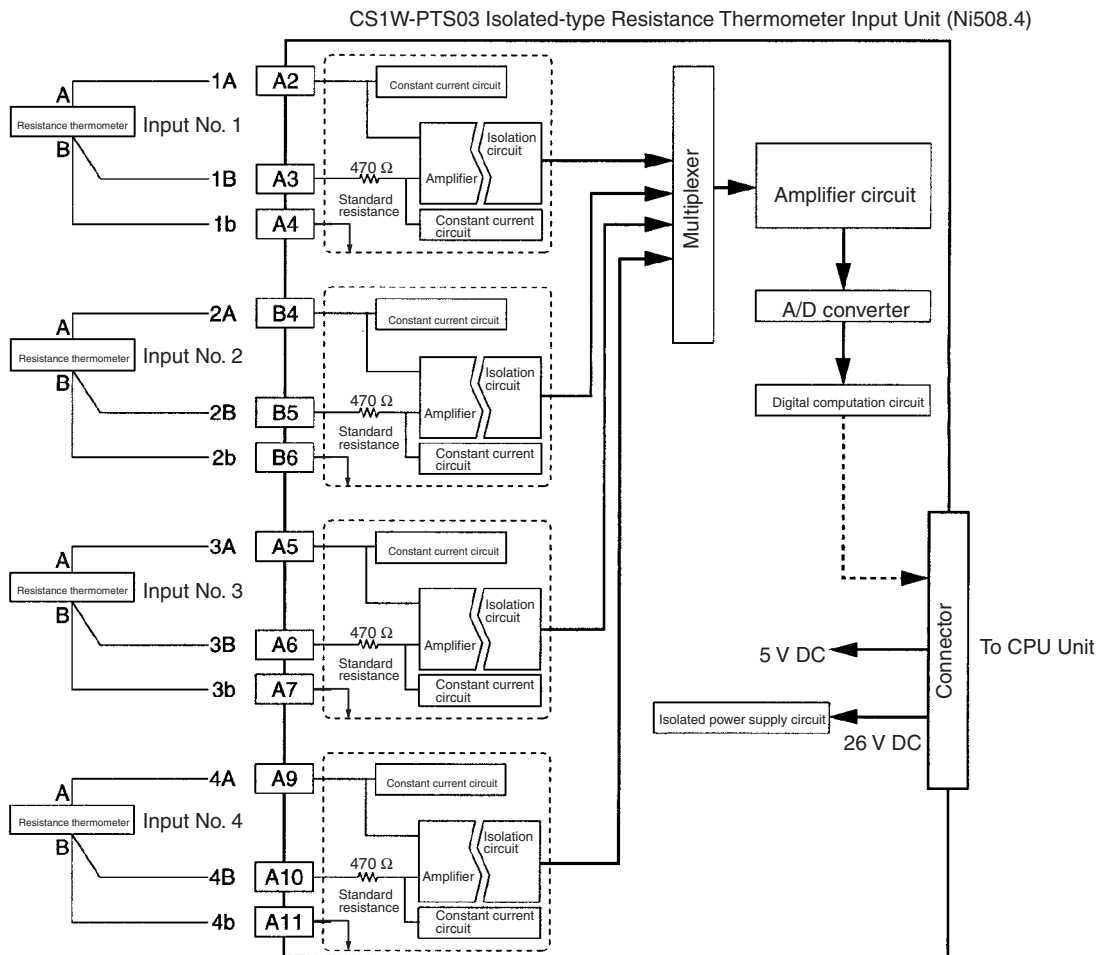

Error Processing

Conversion Data Does Not Change.

| Probable cause | Remedy |
|--|--|
| The gain for span adjustment is set to 0. | Set the gain for span adjustment to a value other than 0. |
| The minimum and maximum values for process value scaling are either the same or are set extremely low. | Set the minimum and maximum values correctly. |
| The sensor type, input range, or process value scaling is not set correctly. | Check and correct the settings. |
| An input device is malfunctioning, input wiring is faulty, or wiring is disconnected. | Check whether the input voltage or current has changed. Check for faulty or disconnected wiring. Check whether a wiring disconnection has been detected in the I/O Area. |

Values are Not Converted as Intended.

| Probable cause | Remedy |
|--|--|
| The sensor type, input range, or process value scaling is not set correctly. | Check and correct the settings. |
| The zero/span adjustment data is incorrect. | Check and correct the zero/span adjustment settings. |
| The resistance thermometer input wiring is faulty. | Correct the input wiring. |

Converted Values are Unstable.

| Probable cause | Remedy |
|--|---|
| Input signals are being affected by external noise. | Change the connection paths of the input signal lines. (Separate them from sources of noise or use shielded cable.) |
| | Increase the number of values for calculating the moving average in mean value processing. |
| The process value scaling value is greater than the Unit's resolution. | Reduce the process value scaling value. |
| The input signal range setting is too small. | Match the input signal range to the internal ranges. |

2-7 CS1W-PTS12 Isolated-type Resistance Thermometer Input Unit (Pt100, JPt100, Pt50, Ni508.4)

Overview

The CS1W-PTS12 Isolated-type Resistance Thermometer Input Unit provides four direct resistance thermometer inputs, and sends the data to the CPU Unit each cycle. All inputs are isolated.

CS1W-PTS12

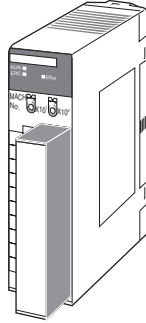

System Configuration

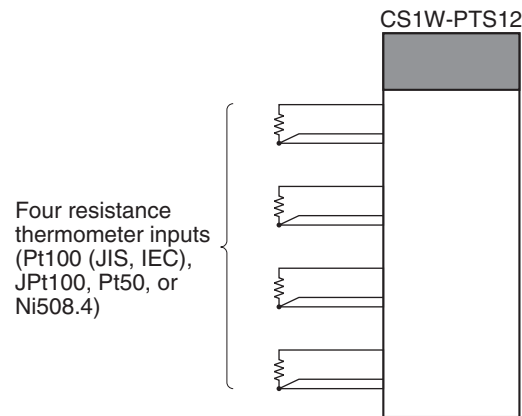

Features

- Up to four resistance thermometers can be connected for each Unit (with four separate settings for temperature sensors and input ranges).
- Pt100 (JIS, IEC), JPt100, Pt50, or Ni508.4 can be selected.
- 1/64,000 resolution for all temperature specifications.
- High-speed conversion of 20 ms/4 inputs and 10 ms/2 inputs.
- Temperature sensor values are transmitted to the CPU Unit in four digits hexadecimal.
- Variable input range setting.
- Four values for each process value alarm input.
- ON-delay timer for process value alarm.
- Mean value processing.
- Rate-of-change calculation.
- Two values for each rate-of-change alarm input.
- Zero/span adjustment capability during operation.
- Disconnection detection.
- Maximum or minimum process value can be specified for when a disconnection is detected.
- Adjustment period control.

- Peak and bottom detection.
- Top and valley detection.

Model Information

| Unit classification | Model number | Inputs | Input types |
|----------------------------|--------------|--------|---|
| CS-series Special I/O Unit | CS1W-PTS12 | 4 | Resistance thermometer Pt100 (JIS, IEC), JPt100, Pt50, or Ni508.4 |

Block Diagram (Order of Processing)

The processing for the inputs is as shown in the following diagram.

CPU Unit

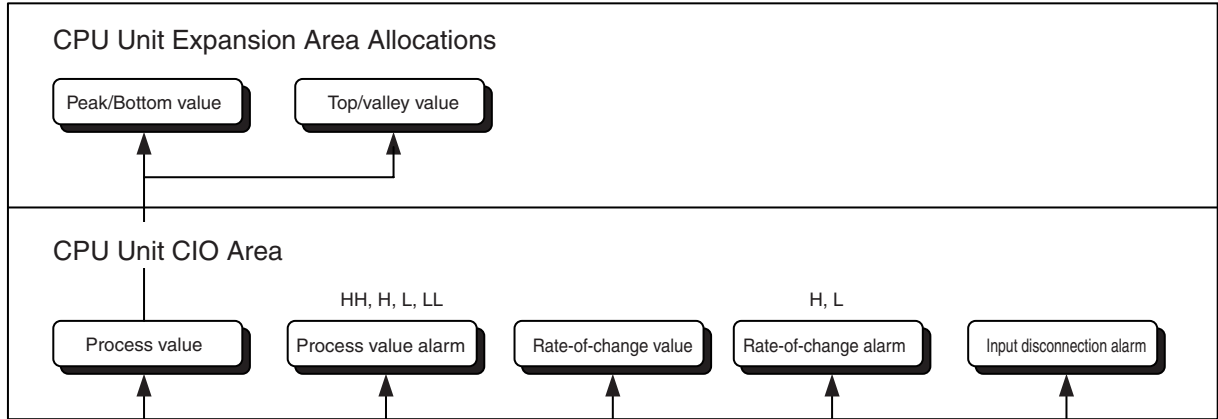

Isolated-type Resistance Thermometer Input Unit

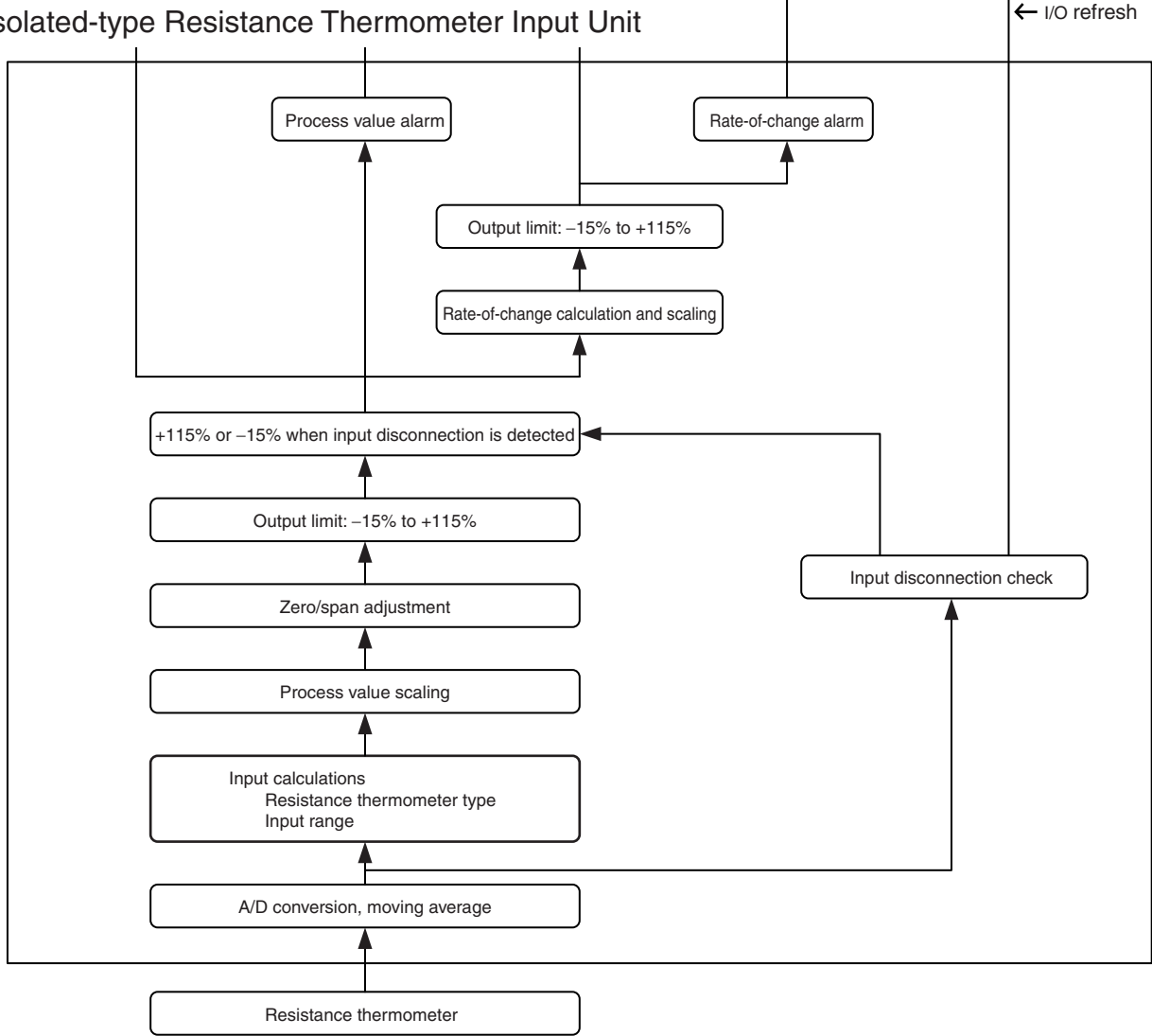

Specifications

| Item | | Specifications |
|---------------------------------------|--|--|
| Model | | CS1W-PTS12 |
| Applicable PLC | | CS Series |
| Unit classification | | CS-series Special I/O Unit |
| Mounting position | | CS-series CPU Rack or CS-series Expansion Rack (Cannot be mounted to C200H Expansion I/O Rack or SYSMAC BUS Remote I/O Slave Rack.) |
| Maximum number of Units | | 80 (within the allowable current consumption and power consumption range) |
| Unit numbers | | 00 to 95 (Cannot duplicate Special I/O Unit numbers.) |
| Areas for data exchange with CPU Unit | Special I/O Unit Area | 10 words/Unit Resistance Thermometer Input Unit to CPU Unit: All process values, process value alarms (LL, L, H, HH), rate-of-change values, rate-of-change alarms (L, H), disconnection alarms, adjustment period end/notices. |
| | DM Area words allocated to Special I/O Units | 100 words/Unit CPU Unit to Resistance Thermometer Input Unit: Temperature sensor type, input range (user set), scaling of process value data to be stored in allocated words in CIO area, rate-of-change input range, scaling of rate-of-change data, number of items for moving average, process value alarm setting (LL, L, H, HH), rate-of-change alarm setting (L, H), zero/span adjustment value. |
| | Expansion Control/Monitor Area words | 35 words/Unit CPU Unit to Resistance Thermometer Input Unit: Hold function selection start/reset, adjustment period control, control bits Resistance Thermometer Input Unit to CPU Unit: Adjustment period warnings/notices, peak and bottom values, top and valley values |
| | Expansion Setting Area words | 46 words/Unit CPU Unit to Resistance Thermometer Input Unit: Expansion Setting Area settings, adjustment period control, peak and bottom detection, top and valley detection |
| Number of temperature sensor inputs | | 4 |
| Temperature sensor type | | Pt100 (JIS, IEC), JPt100, Pt50, Ni508.4 Sensor type, input range, and scaling to industrial units are separate for each of the 4 inputs. |
| Scaling | | Data to be stored in the allocated words in the CIO area must be scaled (with the minimum and maximum values set by user) (4 inputs set separately.). Data can be stored at 0% to 100%. |
| Data storage in the CIO Area | | The value derived from carrying out the following processing in order of the actual process data in the input range is stored in four digits hexadecimal (binary values) in the allocated words in the CIO Area. 1) Mean value processing → 2) Scaling → 3) Zero/span adjustment → 4) Output limits |
| Accuracy (25°C) | | The greater of the following: ±0.05% or ±0.1°C |
| Temperature coefficient | | Pt100: 0.009%/°C JPt100: 0.01%/°C Pt50: 0.02%/°C Ni508.4: 0.012%/°C |
| Resolution | | 1/64,000 |
| Sensing method | | 3-wire method |
| Allowable lead wire resistance | | 20 Ω max. per wire |
| Input detection current | | 0.5 mA |
| Warmup time | | 10 min |
| Response time | | 100 ms (travel time from input 0% to 90%, for step input and with moving average for 4 samples) |
| Conversion period | | 20 ms/4 inputs or 10 ms/2 inputs, selectable in DM Area words allocated to Unit as a Special I/O Unit. |

| Item | | Specifications |
|--|--------------------------------------|---|
| Maximum time to store data in CPU Unit | | Conversion period + one CPU Unit cycle |
| Disconnection detection | | Detects disconnections at each input and turns ON the Disconnection Detection Flag. Hardware detection time: Approx. 0.5 s max. The process value overrange direction for when a disconnection occurs can be specified. (High: 115% of set input range; low: -15% of set input range) |
| Function | Mean value processing (input filter) | Calculates the moving average for the specified number of process values (1 to 128), and stores that value in the CIO Area as the process value. |
| | Process value alarm | Process value 4-point alarm (HH, H, LL, L), alarm hysteresis, and ON-delay timer (0 to 60 s are available). |
| | Rate-of-change calculation | Calculates the amount of change per comparison time interval (1 to 16 s). |
| | Rate-of-change alarm | Rate-of-change 2-point alarm (H, L), alarm hysteresis, and ON-delay timer (0 to 60 s are available, shared with process value alarm). |
| | Adjustment period control | When zero/span adjustment is executed, the date is internally recorded at the Unit. When the preset zero/span adjustment period and the notice of days remaining have elapsed, this function turns ON a warning flag to give notice that it is time for readjustment. |
| | Peak and bottom detection | Detects the maximum (peak) and minimum (bottom) analog input values, from when the Hold Start Bit (output) allocated to the Expansion Control/Monitor Area turns ON until it turns OFF. These values are stored as the peak and bottom values in the Expansion Control/Monitor Area. |
| Top and valley detection | | This function detects the top and valley values for analog inputs, from when the Hold Start Bit (output) allocated to the Expansion Control/Monitor Area turns ON until it turns OFF. These values are stored as the top and valley values in the Expansion Control/Monitor Area. |
| Isolation | | Between temperature inputs and between input terminals and PLC signals: Power supply isolated by transformers, signals isolated by photocouplers. |
| Insulation resistance | | 20 MΩ (at 500 V DC) between inputs |
| Dielectric strength | | Between inputs: 1,000 V AC, at 50/60 Hz, for 1 min, leakage current 10 mA max. |
| External connections | | Terminal block (detachable) |
| Unit number settings | | Set by rotary switches on front panel, from 0 to 95. |
| Indicators | | Three LED indicators on front panel (for normal operation, errors detected at the Resistance Thermometer Input Unit, and errors detected at the CPU Unit). |
| Front panel connector | | Sensor input connector terminal block (detachable) |
| Effect on CPU Unit cycle time | | 0.3 ms |
| Current consumption | | 5 V DC at 120 mA max., 26 V DC at 70 mA max. |
| Dimensions | | 35 × 130 × 126 mm (W × H × D) Note The height including the Backplane is 145 mm. |
| Weight | | 450 g max. |
| Standard accessories | | None |

Sensor Type and Input Range

The resistance thermometer type and input range are set in the allocated words in the DM Area for every four inputs. The input range can be set anywhere within the measurable input ranges shown in the following table. Accuracy and resolution, however, are not determined from the set input range, but rather from the measurable input range shown in the following table. Therefore, accuracy and resolution do not change even when a narrow input range is set.

| Sensor type | DM Area setting | Measurable input range |
|-------------|-----------------|------------------------|
| Pt100 | 0 | -200 to 850°C |
| JPt100 | 1 | -200 to 500°C |

| Sensor type | DM Area setting | Measurable input range |
|-------------|-----------------|------------------------|
| Pt50 | 2 | -200 to 649°C |
| Ni508.4 | 3 | -50 to 150°C |

DM Area Allocations

First word: word m. m = D20000 + unit number × 100 (unit number: 0 to 95)

| DM Area address | | | | Data range | | Default | Data contents |
|--|-------------|-------------|-------------|--|------------------------------------|------------------|--|
| Input No. 1 | Input No. 2 | Input No. 3 | Input No. 4 | Decimal | Hexadecimal | | |
| m | | | | 12345, 0 | 3039, 0000 hex | 0000 hex | Default block read command Specifies the direction of data transfer when the PLC is turned ON or the Unit is restarted for DM Area words m+1 to m+93. <ul style="list-style-type: none"> • 12345 (3039 hex): The data in words m+1 to m+93 is transferred from the Resistance Thermometer Input Unit to the CPU Unit. When the transfer is completed, the value will become 0000 hex. • Other than 12345 (3039 hex) (such as 0000 hex): The data in the allocated words of DM Area is transferred from the CPU Unit to the Resistance Thermometer Input Unit. |
| | | | | Number of inputs setting | | | |
| m+1 | | | | 0, 1 | 0000, 0001 hex | 0 | 0: 4 inputs; 1: 2 inputs |
| Setting Group 1 (continuously refreshed area): Parameters that are continuously refreshed during PLC operation (regardless of the CPU Unit's operation mode) | | | | | | | |
| | | | | Process value alarm settings | | | |
| m + 2 | m + 10 | m + 18 | m + 26 | -32768 to 32767 | 8000 to FFFF hex, 0000 to 7FFF hex | 4200 (1068 hex) | Process value HH (high high limit) alarm setting (Set at process value scaling value.) |
| m + 3 | m + 11 | m + 19 | m + 27 | -32768 to 32767 | 8000 to FFFF hex, 0000 to 7FFF hex | 4000 (0FA0 hex) | Process value H (high limit) alarm setting (Set at process value scaling value.) |
| m + 4 | m + 12 | m + 20 | m + 28 | -32768 to 32767 | 8000 to FFFF hex, 0000 to 7FFF hex | 0 (0000 hex) | Process value L (low limit) alarm setting (Set at process value scaling value.) |
| m + 5 | m + 13 | m + 21 | m + 29 | -32768 to 32767 | 8000 to FFFF hex, 0000 to 7FFF hex | -200 (FF38 hex) | Process value LL (low low limit) alarm setting (Set at process value scaling value.) |
| | | | | Rate-of-change value alarm settings | | | |
| m + 6 | m + 14 | m + 22 | m + 30 | -32768 to 32767 | 8000 to FFFF hex, 0000 to 7FFF hex | 4000 (0FA0 hex) | Rate-of-change value H (high limit) alarm setting (Set at rate-of-change scaling value.) |
| m + 7 | m + 15 | m + 23 | m + 31 | -32768 to 32767 | 8000 to FFFF hex, 0000 to 7FFF hex | 0 (0000 hex) | Rate-of-change value L (low limit) alarm setting (Set at rate-of-change scaling value.) |
| | | | | Zero/span adjustment | | | |
| m + 8 | m + 16 | m + 24 | m + 32 | 0 to 32000 | 0000 to 7D00 hex | 10000 (2710 hex) | Gain for span adjustment (set value × 0.0001%) |
| m + 9 | m + 17 | m + 25 | m + 33 | -32000 to 32000 | 8300 to FFFF hex, 0000 to 7D00 hex | 0 (0000 hex) | Zero adjustment value (Set at process value scaling.) |
| Setting Group 2 (initial settings area): Parameters that are transferred one time from the CPU Unit to the Resistance Thermometer Input Unit if word m contains other than 12345 when the PLC is turned ON or the Resistance Thermometer Input Unit is restarted. | | | | | | | |
| | | | | Sensor type | | | |
| m+34 | m+49 | m+64 | m+79 | 0 to 3 | 0000 to 0003 hex | 0 (0000 hex) | 0: Pt100; 1: JPt100; 2: Pt50; 3: Ni508.4 |
| | | | | Process value input range settings | | | |
| m+35 | m+50 | m+65 | m+80 | -32000 to 32000 | 8300 to FFFF hex, 0000 to 7D00 hex | 4000 (0FA0 hex) | Maximum input signal value (set value × 0.1°C/°F) |
| m+36 | m+51 | m+66 | m+81 | -32000 to 32000 | 8300 to FFFF hex, 0000 to 7D00 hex | 0 (0000 hex) | Minimum input signal value (set value × 0.1°C/°F) |

| DM Area address | | | | Data range | | Default | Data contents | |
|---|-------------|-------------|-------------|---------------------|------------------------------------|------------------|---|--|
| Input No. 1 | Input No. 2 | Input No. 3 | Input No. 4 | Decimal | Hexadecimal | | | |
| m+37 | m+52 | m+67 | m+82 | 0, 1 | 0000, 0001 hex | 0 (0000 hex) | Unit 0: °C, 1: °F | |
| | | | | | | | Process value overrange direction at time of input disconnection | |
| m+38 | m+53 | m+68 | m+83 | 0, 1 | 0000, 0001 hex | 0 (0000 hex) | 0: High; 1: Low | |
| | | | | | | | Process value scaling | |
| m+39 | m+54 | m+69 | m+84 | -32000 to 32000 | 8300 to FFFF hex, 0000 to 7D00 hex | 4000 (0FA0 hex) | Value stored for maximum value in range (span) | |
| m+40 | m+55 | m+70 | m+85 | -32000 to 32000 | 8300 to FFFF hex, 0000 to 7D00 hex | 0 (0000 hex) | Value stored for minimum value in range (zero) | |
| | | | | | | | Alarm supplementary functions | |
| m+41 | m+56 | m+71 | m+86 | 0 to 32000 | 0000 to 7D00 hex | 40 (0028 hex) | Alarm hysteresis (Set at process value scaling value. Shared with process value alarm and rate-of-change alarm.) | |
| m+42 | m+57 | m+72 | m+87 | 0 to 60 | 0000 to 003C hex | 0 (0000 hex) | Alarm ON-delay time (Unit: s) (Shared with process value alarm and rate-of-change alarm.) | |
| | | | | | | | Rate-of-change function | |
| m+43 | m+58 | m+73 | m+88 | -32000 to 32000 | 8300 to FFFF hex, 0000 to 7D00 hex | 4000 (0FA0 hex) | Rate-of-change range setting | Maximum rate-of-change value (Set value industrial unit; comparison time interval) |
| m+44 | m+59 | m+74 | m+89 | -32000 to 32000 | 8300 to FFFF hex, 0000 to 7D00 hex | -4000 (F060 hex) | | Minimum rate-of-change value (Set value industrial unit; comparison time interval) |
| m+45 | m+60 | m+75 | m+90 | 1 to 16 | 0001 to 0010 hex | 1 (0001 hex) | Rate-of-change comparison time interval (Unit: s) | |
| m+46 | m+61 | m+76 | m+91 | -32000 to 32000 | 8300 to FFFF hex, 0000 to 7D00 hex | 4000 (0FA0 hex) | Rate-of-change value scaling | Value stored for maximum value in range |
| m+47 | m+62 | m+77 | m+92 | -32000 to 32000 | 8300 to FFFF hex, 0000 to 7D00 hex | -4000 (F060 hex) | | Value stored for minimum value in range |
| | | | | | | | Mean value processing function | |
| m+48 | m+63 | m+78 | m+93 | 1 to 128 | 0001 to 0080 hex | 25 (0019 hex) | Number of process values for calculating moving average for mean value processing | |
| Display parameter | | | | | | | | |
| m+94 | m+95 | m+96 | m+97 | 0 to 99, 100 to 1XX | 0000 to 0063 hex, 0064 to 0XXX hex | 0 (0000 hex) | Address of Data Range Error (See note.) | |
| Expansion Setting Area allocation settings | | | | | | | | |
| m+98 | | | | 0 to 5 | 0000 to 0005 hex | --- | Expansion Setting Area allocation 0: Not used; 1: DM; 2: CIO; 3: W; 4: H; 5: EM | |
| m+99 | | | | 0 to 32767 | 0000 to 7FFF hex | --- | First word for Expansion Setting Area | |

- Note** 1. The ERC indicator on the Unit's front panel will light if an out-of-range setting is made in either Setting Group 1 or 2, or in the Expansion Setting Area. The offset from word m to the first word containing the out-of-range error will be stored as the Address of Data Range Error in the DM Area in four digits hexadecimal. For more information, refer to *1-6 Error Processing*.

If the first memory address where the out-of-range error occurred is in the Expansion Setting Area, the Address of Data Range Area will be +100 or later. If the first word of the Expansion Setting Area has the error, the Address of Data Range Area will be +100.

2. When specifying an expansion setting area, be sure that it does not overlap with other areas that are being used. If areas overlap, the words that are allocated may be overwritten, resulting in unexpected operation.
3. When specifying the first word in an expansion setting area, be sure that the end of the memory area is not exceeded.

Expansion Setting Area Allocations

First word: word o. o = address specified in word m+99 in the area specified by word m+98 in the DM Area.

| DM Area address | | | | Data range | | Default | Data contents |
|---|-------------|-------------|-------------|-----------------|------------------------------------|-----------------|--|
| Input No. 1 | Input No. 2 | Input No. 3 | Input No. 4 | Decimal | Hexadecimal | | |
| Setting Group 3 (initial settings area): Parameters that are transferred one time from the CPU Unit to the Resistance Thermometer Input Unit if word m contains other than 12345, and if Expansion Setting Area settings are allocated, when the PLC is turned ON or the Resistance Thermometer Input Unit is restarted. | | | | | | | |
| | | | | | | | Expansion Control/Monitor Area settings |
| o | | | | 0 to 5 | 0000 to 0005 hex | --- | Expansion Control/Monitor Area allocation 0: Not used. 1: DM; 2: CIO; 3: W; 4: H; 5: EM |
| o+1 | | | | 0 to 32767 | 0000 to 7FFF hex | --- | Expansion Control/Monitor Area first word |
| | | | | | | | Zero/span adjustment supplementary function |
| o+2 | o+13 | o+24 | o+35 | 0 to 32000 | 0000 to 7D00 hex | 1000 (2710 hex) | Span adjustment position (Input span percentage) |
| o+3 | o+14 | o+25 | o+36 | -32000 to 32000 | 8300 to FFFF hex, 0000 to 7D00 hex | 0 (0000 hex) | Zero adjustment position (Input span percentage) |
| o+4 | o+15 | o+26 | o+37 | 0 to 9999 | 0000 to 270F hex | 365 (016D hex) | Zero/span adjustment period (Unit: Days) |
| o+5 | o+16 | o+27 | o+38 | 0 to 9999 | 0000 to 270F hex | 30 (001E hex) | Notice of days remaining (Unit: Days) |
| | | | | | | | Not used. |
| o+6 | o+17 | o+28 | o+39 | --- | --- | 0 (0000 hex) | Not used. |
| o+7 | o+18 | o+29 | o+40 | | | | |
| o+8 | o+19 | o+30 | o+41 | | | | |
| | | | | | | | Top and valley hold |
| o+9 | o+20 | o+31 | o+42 | 0 to 32000 | 0000 to 7D00 hex | 40 (0028 hex) | Hysteresis |
| | | | | | | | Not used. |
| o+10 | o+21 | o+32 | o+43 | --- | --- | 0 (0000 hex) | Not used. |
| o+11 | o+22 | o+33 | o+44 | | | | |
| o+12 | o+23 | o+34 | o+45 | | | | |

- Note**
1. When specifying an expansion control/monitor area be sure that it does not overlap with other areas that are being used. If areas overlap, the words that are allocated may be overwritten, resulting in unexpected operation.
 2. When specifying the first word in an expansion control/monitor area be sure that the end of the memory area is not exceeded.

CIO Area Allocations

First word: word n. n = 2000 + unit number × 10 (unit number: 0 to 95)

| Direction | Word | Bit | Name | | Data range | Contents |
|---|------|-----|-------------|--|------------|------------------------------|
| Resistance Thermometer Input Unit to CPU Unit | n | 00 | Input No. 1 | Process value LL (low low limit) alarm | 0, 1 | 0: Process value > Set value |
| | | 01 | | Process value L (low limit) alarm | 0, 1 | 1: Process value ≤ Set value |
| | | 02 | | Process value H (high limit) alarm | 0, 1 | 0: Process value < Set value |
| | | 03 | | Process value HH (high high limit) alarm | 0, 1 | 1: Process value ≥ Set value |
| | | 04 | Input No. 2 | Process value LL (low low limit) alarm | 0, 1 | Same as for input No. 1. |
| | | 05 | | Process value L (low limit) alarm | 0, 1 | |
| | | 06 | | Process value H (high limit) alarm | 0, 1 | |
| | | 07 | | Process value HH (high high limit) alarm | 0, 1 | |
| | | 08 | Input No. 3 | Process value LL (low low limit) alarm | 0, 1 | Same as for input No. 1. |
| | | 09 | | Process value L (low limit) alarm | 0, 1 | |
| | | 10 | | Process value H (high limit) alarm | 0, 1 | |
| | | 11 | | Process value HH (high high limit) alarm | 0, 1 | |
| | | 12 | Input No. 4 | Process value LL (low low limit) alarm | 0, 1 | Same as for input No. 1. |
| | | 13 | | Process value L (low limit) alarm | 0, 1 | |
| | | 14 | | Process value H (high limit) alarm | 0, 1 | |
| | | 15 | | Process value HH (high high limit) alarm | 0, 1 | |

| Direction | Word | Bit | Name | | Data range | Contents | |
|---|-------|----------|----------------------------------|------------------------------------|---|--|--|
| Resistance Thermometer Input Unit to CPU Unit | n + 1 | 00 to 15 | Input No. 1 process value | | -32768 to 32767 (8000 to FFFF hex, 0000 to 7FFF hex) | The present process value is stored according to the scaling set in the allocated words of the DM Area. | |
| | n + 2 | 00 to 15 | Input No. 2 process value | | -32768 to 32767 (8000 to FFFF hex, 0000 to 7FFF hex) | | |
| | n + 3 | 00 to 15 | Input No. 3 process value | | -32768 to 32767 (8000 to FFFF hex, 0000 to 7FFF hex) | | |
| | n + 4 | 00 to 15 | Input No. 4 process value | | -32768 to 32767 (8000 to FFFF hex, 0000 to 7FFF hex) | | |
| | n + 5 | 00 to 15 | Input No. 1 rate-of-change value | | -32768 to 32767 (8000 to FFFF hex, 0000 to 7FFF hex) | The present rate of change is stored according to the scaling set in the allocated words of the DM Area. | |
| | n + 6 | 00 to 15 | Input No. 2 rate-of-change value | | -32768 to 32767 (8000 to FFFF hex, 0000 to 7FFF hex) | | |
| | n + 7 | 00 to 15 | Input No. 3 rate-of-change value | | -32768 to 32767 (8000 to FFFF hex, 0000 to 7FFF hex) | | |
| | n + 8 | 00 to 15 | Input No. 4 rate-of-change value | | -32768 to 32767 (8000 to FFFF hex, 0000 to 7FFF hex) | | |
| | n + 9 | 00 | | Input No. 1 | Rate-of-change value L (low limit) alarm | 0, 1 | 0: Rate-of-change value > Set value 1: Rate-of-change value ≤ Set value |
| | | | | | Rate-of-change value H (high limit) alarm | 0, 1 | |
| | | 02 | | Input No. 2 | Rate-of-change value L (low limit) alarm | 0, 1 | Same as for input No. 1. |
| | | | | | Rate-of-change value H (high limit) alarm | 0, 1 | |
| | | 04 | | Input No. 3 | Rate-of-change value L (low limit) alarm | 0, 1 | Same as for input No. 1. |
| | | | | | Rate-of-change value H (high limit) alarm | 0, 1 | |
| | | 06 | | Input No. 4 | Rate-of-change value L (low limit) alarm | 0, 1 | Same as for input No. 1. |
| Rate-of-change value H (high limit) alarm | | | | | 0, 1 | | |
| 08 | | | | Input No. 1 input error | 0, 1 | 0: Normal 1: Disconnection | |
| 09 | | | | Input No. 2 input error | 0, 1 | | |
| 10 | | | | Input No. 3 input error | 0, 1 | Same as for input No. 1. | |
| 11 | | | | Input No. 4 input error | 0, 1 | Same as for input No. 1. | |
| 12 | | | | Not used. | 0 | --- | |
| 13 | | | | Zero/span adjustment period end | 0, 1 | 0: Adjustment enabled 1: Adjustment ended | |
| 14 | | | | Zero/span adjustment period notice | 0, 1 | 0: Adjustment enabled 1: Notice period | |
| 15 | | | Not used. | 0 | --- | | |

Expansion Control/Monitor Area Allocations

First word: word p. p = address specified in word o+1 in the area specified by word o in the Expansion Setting Area.

| Direction | Word | Bit | Name | Data range | Contents | |
|---|----------|----------|---|---|---|---|
| CPU Unit to Resistance Thermometer Input Unit | p | 00 to 15 | Not used. | Not used. | Not used. | |
| | p+1 | 00 | Input No. 1 hold function selection | 0, 1 | 0: Peak and bottom 1: Top and valley | |
| | | 01 | Input No. 2 hold function selection | 0, 1 | | |
| | | 02 | Input No. 3 hold function selection | 0, 1 | | |
| | | 03 | Input No. 4 hold function selection | 0, 1 | | |
| | | 04 to 07 | Not used. | 0 | | Not used. |
| | | 08 | Input No. 1 hold start | 0, 1 | 0: Do not hold. 1: Hold | |
| | | 09 | Input No. 2 hold start | 0, 1 | | |
| | | 10 | Input No. 3 hold start | 0, 1 | | |
| | | 11 | Input No. 4 hold start | 0, 1 | | |
| | | 12 | Input No. 1 hold value reset | 0, 1 | 0: Normal operation 1: Reset hold value. | |
| | | 13 | Input No. 2 hold value reset | 0, 1 | | |
| | | 14 | Input No. 3 hold value reset | 0, 1 | | |
| | | 15 | Input No. 4 hold value reset | 0, 1 | | |
| | | p+2 | 00 | Input No. 1 zero/span adjustment update bit | 0, 1 | 0: Normal operation 1: Update adjustment date (Remains ON while writing external FROM.) |
| | | | 01 | Input No. 2 zero/span adjustment update bit | 0, 1 | |
| | 02 | | Input No. 3 zero/span adjustment update bit | 0, 1 | | |
| | 03 | | Input No. 4 zero/span adjustment update bit | 0, 1 | | |
| | 04 to 15 | | Not used. | 0 | Not used. | |

| Direction | Word | Bit | Name | | Data range | Contents |
|---|--------------|-----------|--------------------------|---|--------------------|---|
| Resistance Thermometer Input Unit to CPU Unit | p+3 | 00 | Input No. 1 | Zero/span adjustment period end | 0, 1 | 0: Adjustment enabled. 1: Adjustment period end |
| | | 01 | | Zero/span adjustment period notice | 0, 1 | 0: Adjustment enabled. 1: Notice period in effect. |
| | | 02 | Input No. 2 | Zero/span adjustment period end | 0, 1 | Remains set to 1 if the zero/span adjustment bit has never been ON. |
| | | 03 | | Zero/span adjustment period notice | 0, 1 | |
| | | 04 | Input No. 3 | Zero/span adjustment period end | 0, 1 | |
| | | 05 | | Zero/span adjustment period notice | 0, 1 | |
| | | 06 | Input No. 4 | Zero/span adjustment period end | 0, 1 | |
| | | 07 | | Zero/span adjustment period notice | 0, 1 | |
| | | 08 | External FROM Error Flag | | 0, 1 | |
| | 09 to 15 | Not used. | | 0 | Not used. | |
| | p+4 | 00 to 15 | Input No. 1 | Day of final adjustment date | 0100 to 3100 (BCD) | |
| | p+5 | 00 to 15 | | Year and month of final adjustment date | 0001 to 9912 (BCD) | |
| | p+6 | 00 to 15 | Input No. 2 | Day of final adjustment date | 0100 to 3100 (BCD) | |
| | p+7 | 00 to 15 | | Year and month of final adjustment date | 0001 to 9912 (BCD) | |
| | p+8 | 00 to 15 | Input No. 3 | Day of final adjustment date | 0100 to 3100 (BCD) | |
| | p+9 | 00 to 15 | | Year and month of final adjustment date | 0001 to 9912 (BCD) | |
| | p+10 | 00 to 15 | Input No. 4 | Day of final adjustment date | 0100 to 3100 (BCD) | |
| | p+11 | 00 to 15 | | Year and month of final adjustment date | 0001 to 9912 (BCD) | |
| | p+12 to p+15 | 00 to 15 | Not used. | | 0 | Not used. |

| Direction | Word | Bit | Name | | Data range | Contents |
|---|--------------|----------|-------------|---------------------|--|---|
| Resistance Thermometer Input Unit to CPU Unit | p+16 | 00 to 15 | Input No. 1 | Peak/top value | -32728 to +32767 (8000 to FFFF hex, 0000 to 7FFF hex) | Counts the number of repetitions of conditional operations set in the Expansion Setting Area. |
| | p+17 | 00 to 15 | | Bottom/valley value | -32728 to +32767 (8000 to FFFF hex, 0000 to 7FFF hex) | |
| | p+18 | 00 to 15 | Input No. 2 | Peak/top value | -32728 to +32767 (8000 to FFFF hex, 0000 to 7FFF hex) | Same as for Input No. 1. |
| | p+19 | 00 to 15 | | Bottom/valley value | -32728 to +32767 (8000 to FFFF hex, 0000 to 7FFF hex) | |
| | p+20 | 00 to 15 | Input No. 3 | Peak/top value | -32728 to +32767 (8000 to FFFF hex, 0000 to 7FFF hex) | |
| | p+21 | 00 to 15 | | Bottom/valley value | -32728 to +32767 (8000 to FFFF hex, 0000 to 7FFF hex) | |
| | p+22 | 00 to 15 | Input No. 4 | Peak/top value | -32728 to +32767 (8000 to FFFF hex, 0000 to 7FFF hex) | |
| | p+23 | 00 to 15 | | Bottom/valley value | -32728 to +32767 (8000 to FFFF hex, 0000 to 7FFF hex) | |
| | p+24 to p+34 | 00 to 15 | Not used. | | 0 (0000 hex) | Not used. |

Terminal Connection Diagram

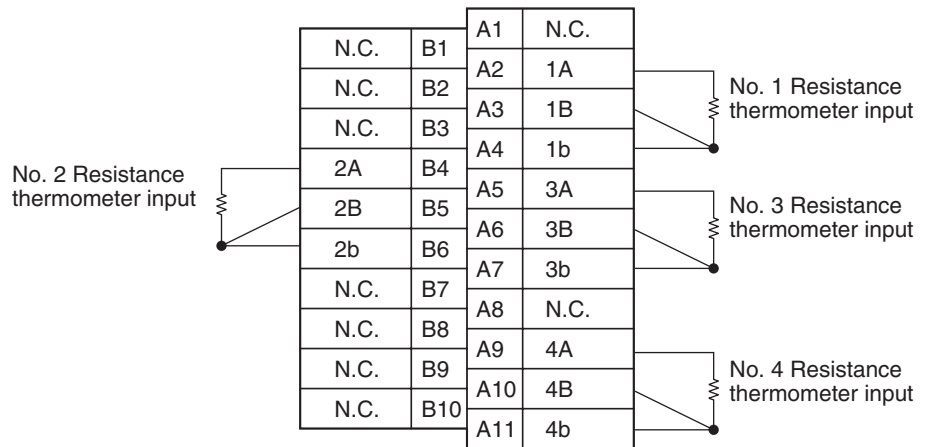

- Note**
- Wire the same length to A, B, and b, so that the impedance will be the same. In particular, do not short circuit between B and b at the terminal block.
 - For unused input terminals, short-circuit between A-B and B-b (e.g., A2-A3 and A3-A4 for input No. 1) of the resistance thermometer inputs with the lead wire.
 - Always ground the GR terminal on the Power Supply Unit of the PLC.

- If the input device uses a voltage generator, temperature compensator, or similar device, then ground the input device if it has a ground terminal.

Terminal Block Diagram

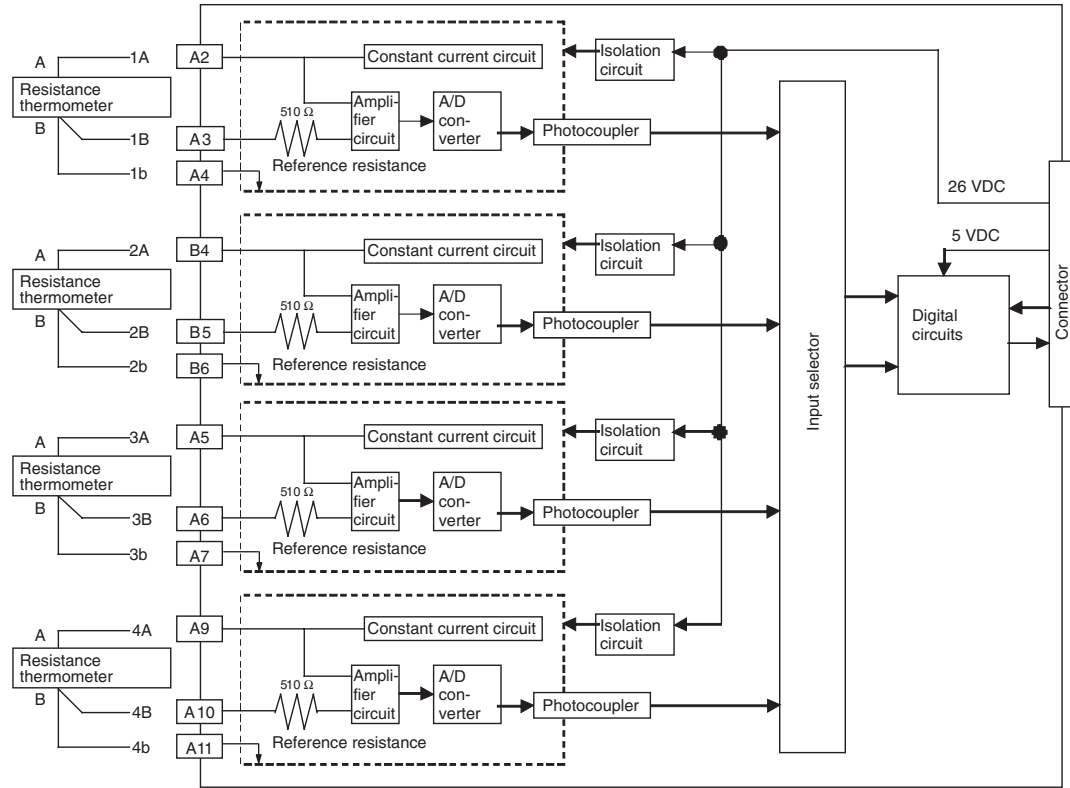

Error Processing

Conversion Data Does Not Change.

| Probable cause | Remedy |
|--|---|
| The gain for span adjustment is set to 0. | Set the gain for span adjustment to a value other than 0. |
| The minimum and maximum values for process value scaling are either the same or are set extremely low. | Set the minimum and maximum process value scaling correctly. |
| The sensor type, or process value scaling is not set correctly. | Check and reset the sensor type, and the process value scaling settings. |
| An input device is malfunctioning, input wiring is faulty, or wiring is disconnected. | Check whether the input voltage or current has changed. Check for faulty or disconnected wiring. Check whether a disconnection has been detected in the I/O Area. |

Values are Not Converted as Intended.

| Probable cause | Remedy |
|---|--|
| The sensor type, or process value scaling is set incorrectly. | Check and reset the sensor type, and the process value scaling settings. |
| The zero/span adjustment data is incorrect. | Check and correct the zero/span adjustment settings. |
| The resistance thermometer input wiring is faulty. | Check and correct the input wiring. |

Converted Values are Unstable.

| Probable cause | Remedy |
|--|---|
| Input signals are being affected by external noise. | Change the connection paths of the input signal lines. (Separate them from sources of noise or use shielded cable.) |
| | Increase the number of values for calculating the moving average in mean value processing. |
| The scaling value is greater than the Unit's resolution. | Reduce the process value scaling. |
| The input signal range is too small. | Change to match the internal range. |

2-8 CS1W-PTS52 Isolated-type Resistance Thermometer Input Unit (Pt100, JPt100)

Overview

The CS1W-PTS52 Isolated-type Resistance Thermometer Input Unit provides four direct platinum resistance thermometer inputs, and sends the data to the CPU Unit each cycle. All inputs are isolated.

CS1W-PTS52

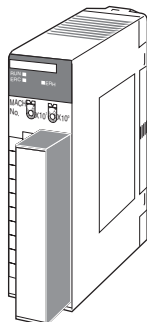

System Configuration

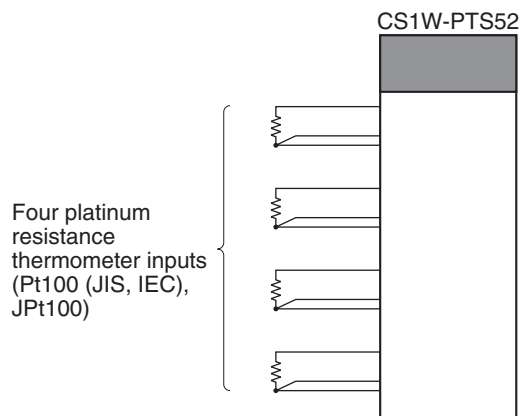

Features

- Up to four platinum resistance thermometers can be connected for each Unit (with four separate settings for temperature sensors and input ranges).
- Pt100 (JIS, IEC), JPt100 can be selected.
- Temperature sensor values are transmitted to the CPU Unit in four digits hexadecimal. (Either binary or BCD data output can be selected.)
- Process value alarm (two alarms in internal memory and one external alarm output for each input).
- Alarm ON-delay timer and hysteresis for process value.
- Zero/span adjustment capability during operation.
- Sensor error detection.
- Maximum or minimum process value can be specified for when a sensor error is detected.

Model Information

| Unit classification | Model number | Inputs | Input types |
|----------------------------|--------------|--------|--|
| CS-series Special I/O Unit | CS1W-PTS52 | 4 | Platinum resistance thermometer Pt100 (JIS, IEC), JPt100 |

Block Diagram (Order of Processing)

The processing for the inputs is as shown in the following diagram.

CPU Unit

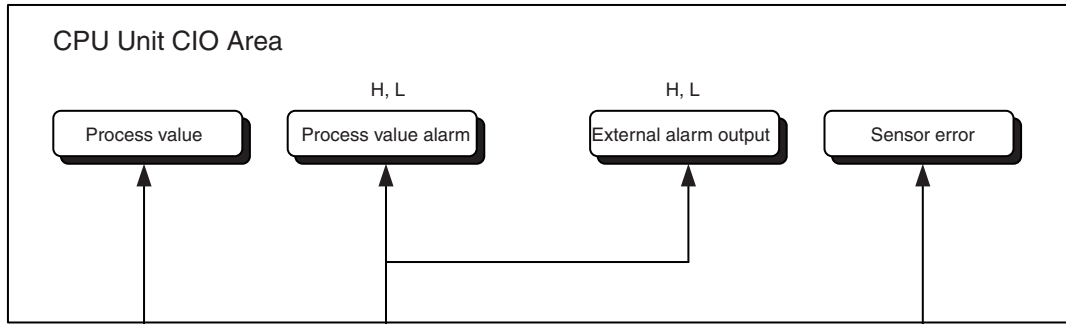

Isolated-type Resistance Thermometer Input Unit

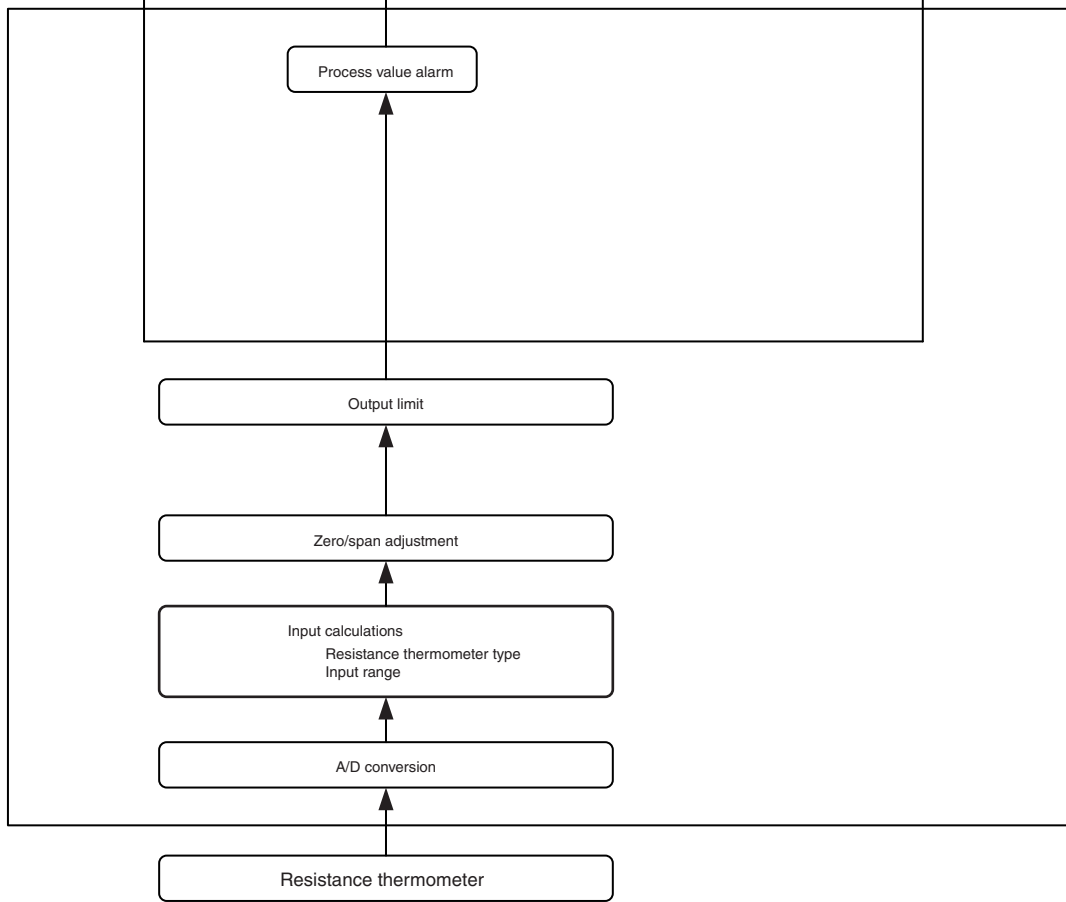

Specifications

| Item | Specifications |
|-------------------------|---|
| Model | CS1W-PTS52 |
| Applicable PLC | CS Series |
| Unit classification | CS-series Special I/O Unit |
| Mounting position | CS-series CPU Rack or CS-series Expansion Rack (Cannot be mounted to C200H Expansion I/O Rack or SYSMAC BUS Remote I/O Slave Rack.) |
| Maximum number of Units | 80 (within the allowable current consumption and power consumption range) |
| Unit numbers | 00 to 95 (Cannot duplicate Special I/O Unit numbers.) |

| Item | | Specifications |
|--|--|--|
| Areas for data exchange with CPU Unit | Special I/O Unit Area | 10 words/Unit Resistance Thermometer Input Unit to CPU Unit: All process values, process value alarms (L, H), conversion data enabled flag, sensor errors. |
| | DM Area words allocated to Special I/O Units | 100 words/Unit CPU Unit to Resistance Thermometer Input Unit: Temperature sensor type, input range (user set), process value alarm setting (L, H), zero/span adjustment value. |
| Number of temperature sensor inputs | | 4 |
| Temperature sensor type | | Pt100 (JIS, IEC), JPt100 The same sensor type, input range, and scaling to industrial units are used by all inputs. |
| Data storage in the CIO Area | | The actual process data in the input range is stored in four digits hexadecimal (binary or BCD values) in the allocated words in the CIO Area. |
| Accuracy (25°C) | | ±0.3% of PV or ±0.8°C, whichever is greater, ±1 digit max. (±0.3% of PV or ±1.6°F, whichever is greater, ±1 digit max.) PV: Process value data |
| Temperature characteristics | | Refer to <i>Temperature Characteristics According to Platinum Resistance Thermometer Type</i> on page 161. |
| Sensing method | | 3-wire method |
| Input detection current | | 1 mA |
| Influence of conductor resistance | | 0.4°C/Ω max. |
| Conversion period | | 250 ms/4 inputs |
| Warmup time | | 10 min |
| Maximum time to store data in CPU Unit | | Conversion period + one CPU Unit cycle |
| Sensor error detection | | Detects sensor error at each input and turns ON the Sensor error Flag. Hardware detection time: Approx. 0.5 s max. The process value overrange direction for when a sensor error occurs can be specified. (High: +20 digit of set input range; low: -20 digit of set input range) |
| Function | Process value alarm | Process value 2-point alarm (H, L), alarm hysteresis, and ON-delay timer (0 to 60 s are available). |
| | External alarm outputs | NPN outputs (with short-circuit protection) External power supply voltage: 20.4 to 26.4 V DC Max. switching capacity: 100 mA (for one output) Leakage current: 0.3 mA max. Residual voltage: 3 V max. |
| Isolation | | Between inputs and PLC signal: Transformer for power supply and photocoupler for signals Between each input: Transformer for power supply and photocoupler for signals |
| Insulation resistance | | 20 MΩ max. (at 500 V DC). Between all output and NC terminals and external AC terminals (Power Supply Unit) Between all input terminals and external AC terminals (Power Supply Unit) Between all input terminals and all output terminals Between all external DC terminals (input, output, and NC terminals) and FG plate Between all input and output terminals and all NC terminals |

| Item | Specifications |
|-------------------------------|---|
| Dielectric strength | Between all output and NC terminals and external AC terminals (Power Supply Unit) 2,000 V AC, 50/60 Hz 1 min., detection current: 1 mA Between all input terminals and external AC terminals (Power Supply Unit) Between all input terminals and all output terminals Between all external DC terminals (input, output, and NC terminals) and FG plate 1,000 V AC, 50/60 Hz 1 min., detection current: 1 mA Between all channels 500 VAC, 50/60 Hz 1 min., detection current: 1 mA |
| External connections | Terminal block (detachable) |
| Unit number settings | Set by rotary switches on front panel, from 0 to 95. |
| Indicators | Seven LED indicators on front panel (for normal operation, errors detected at the Unit, errors detected at the CPU Unit, and four indicators for external alarm outputs.) |
| Effect on CPU Unit cycle time | 0.4 ms |
| Current consumption | 5 V DC at 250 mA max |
| Dimensions | 35 × 130 × 126 mm (W × H × D) Note The height including the Backplane is 145 mm. |
| Weight | 450 g max. |

Sensor Type and Input Range

The Platinum Resistance Thermometer type and input range are set in the allocated words in the DM Area for every four inputs.

The measurable data range is ±20 digits wider than the sensor input range.

| Setting | Input | °C | | | | °F | | | |
|---------|--|---|--|------------------------------------|--|--|---|--|--|
| | | 16-bit binary | BCD | | 16-bit binary | BCD | | | |
| | | | F□□□ indicates minus sign. | Leftmost bit indicates minus sign. | | Leftmost 4 bits (bits 12 to 15) indicate minus sign. | Leftmost bit (bit 15) indicates minus sign. | | |
| 0 | Pt100: –200.0 to 650.0°C (–300.0 to 1200.0°F) | F830 to FFFF to 1964 (–200.0 to –0.1 to 650.0) | F999 to 6500 (See note 2.) (–99.9 to 650.0) | A000 to 6500 (–200.0 to 650.0) | F448 to FFFF to 2EE0 (–300.0 to –0.1 to 1200.0) | F999 to 9999 (See note 2.) (–99.9 to 999.9) | B000 to 7999 (See note 2.) (–300.0 to 799.9) | | |
| 1 | JPt100: –200.0 to 650.0°C (–300.0 to 1200.0°F) | F830 to FFFF to 1964 (–200.0 to –0.1 to 650.0) | F999 to 6500 (See note 2.) (–99.9 to 650.0) | A000 to 6500 (–200.0 to 650.0) | F448 to FFFF to 2EE0 (–300.0 to –0.1 to 1200.0) | F999 to 9999 (See note 2.) (–99.9 to 999.9) | B000 to 7999 (See note 2.) (–300.0 to 799.9) | | |
| 2 to 9 | Do not set. | | | | | Do not set. | | | |

- Note**
- If the indication range is exceeded, a sensor error will occur and the sensor error bit will turn ON. The process value will be clamped at the lower or upper limit of the indication range, depending on the setting for data direction at sensor error.
 - The indicator range for BCD display will be clamped at the lower (or upper) limit in the region between the lower (or upper) limit of the setting range and the point where a sensor error occurs.
For 0.1°C/0.1°F indication with minus sign indicated by leftmost 4 bits (bits 12 to 15): Lower limit = –99.9, Upper limit = 999.9.
For 0.1°C/0.1°F indication with minus sign indicated by leftmost bit (bit 15): Lower limit = –799.9, Upper limit = 799.9.

Temperature Characteristics According to Platinum Resistance Thermometer Type

| Platinum Resistance Thermometer | Temperature range | Set value error when ambient temperature changes by 1°C |
|---------------------------------|-------------------|---|
| Pt100 | -200 to 200°C | ±0.06°C |
| | 200 to 650°C | 285 ppm of PV |
| JPt100 | -200 to 200°C | ±0.06°C |
| | 200 to 650°C | 285 ppm of PV |

The measured temperature error is calculated as shown in the following example.

| Item | Details |
|---------------------------------|---|
| Ambient temperature | 30°C |
| Platinum Resistance Thermometer | Pt100 |
| Measured temperature (PV) | 500°C |
| Reference accuracy (25°C) | ±0.3°C of PV or ±0.8°C, whichever is greater, ±1 digit. In this example, ±1.5°C. |
| Temperature characteristics | 200 to 650°C: 285 ppm of PV. In this example, 285 ppm × 500°C = 0.143°C. |
| Change in ambient temperature | 5°C (25 to 30°C) |

Overall accuracy =
 Reference accuracy + Temperature characteristic × Change in ambient temperature = ±1.5°C + ±0.143°C × 5 = Approx. ± 2.2°C ±1 digit.

DM Area Allocations

First word: word m. m = D20000 + unit number × 100 (unit number: 0 to 95)

| DM Area address | | | | Data range | | Default | Data contents |
|---|-------------|-------------|-------------|-----------------------------------|------------------|-------------------------------------|--|
| Input No. 1 | Input No. 2 | Input No. 3 | Input No. 4 | Decimal | Hexadecimal | | |
| m | | | | 12345, 0 | 3039, 0000 hex | 0000 hex | Default block read command Specifies the direction of data transfer when the PLC is turned ON or the Unit is restarted for DM Area words m+1 to m+93. <ul style="list-style-type: none"> 12345 (3039 hex): The data in words m+1 to m+93 is transferred from the Resistance Thermometer Input Unit to the CPU Unit. When the transfer is completed, the value will become 0000 hex. Other than 12345 (3039 hex) (such as 0000 hex): The data in the allocated words of DM Area is transferred from the CPU Unit to the Resistance Thermometer Input Unit. |
| Display parameter | | | | | | | |
| m + 1 | | | | 0 to 34 | 0000 to 0022 hex | 0 (0000 hex) | Address of Data Range Error (See note 1.) |
| Setting Group 1 (continuously refreshed area): Parameters that are continuously refreshed during PLC operation (regardless of the CPU Unit's operation mode) | | | | | | | |
| | | | | | | Process value alarm settings | |
| m + 2 | m + 6 | m + 10 | m + 14 | Low to high limit for all sensors | | 6500 (1964 hex) | Process value H (high limit) alarm setting |
| m + 3 | m + 7 | m + 11 | m + 15 | | | -2000 (F830 hex) | Process value L (low limit) alarm setting |
| | | | | | | Span adjustment value | |

| DM Area address | | | | Data range | | Default | Data contents |
|--|-------------|-------------|-------------|---------------|------------------|------------------|--|
| Input No. 1 | Input No. 2 | Input No. 3 | Input No. 4 | Decimal | Hexadecimal | | |
| m + 4 | m + 8 | m + 12 | m + 16 | 0 to 9999 | 0000 to 270F hex | 1000 (03E8 hex) | m+35 contains 0: Set value × 0.001 |
| | | | | 0 to 32000 | 0000 to 7D00 hex | 10000 (2710 hex) | m+35 contains 1: Set value × 0.0001 |
| | | | | | | | Zero adjustment value |
| m + 5 | m + 9 | m + 13 | m + 17 | -9999 to 9999 | D8F1 to 270F hex | 0 (0000 hex) | Set value × 0.1 |
| Setting Group 2 (initial settings area): Parameters that are transferred one time from the CPU Unit to the Resistance Thermometer Input Unit if word m contains other than 12345 when the PLC is turned ON or the Resistance Thermometer Input Unit is restarted. | | | | | | | |
| | | | | | | | Operation settings (See note 2.) |
| m + 18 | | | | (See note 2.) | (See note 2.) | 0 (0000 hex) | 00 to 03: Temperature unit (°C or °F) 04 to 07: Data display (binary or BCD) 08 to 11: Minus sign display format for BCD display 12 to 15: Data direction at sensor error |
| | | | | | | | Sensor type |
| m + 19 | m + 23 | m + 27 | m + 31 | 0 to 1 | 0000, 0001 hex | 0 (0000 hex) | 0: Pt100; 1: JPt100 |
| | | | | | | | External alarm output mode |
| m + 20 | m + 24 | m + 28 | m + 32 | 0, 1 | 0000, 0001 hex | 0 (0000 hex) | Select either high limit or low limit alarm output. 0: High limit alarm; 1: Low limit alarm |
| | | | | | | | Alarm hysteresis |
| m + 21 | m + 25 | m + 29 | m + 33 | 0 to 9999 | 0000 to 270F hex | 0 (0000 hex) | Set value × 0.1 |
| | | | | | | | Alarm ON-delay time |
| m + 22 | m + 26 | m + 30 | m + 34 | 0 to 60 | 0000 to 003C hex | 0 (0000 hex) | Unit: s |
| m + 35 | | | | 0, 1 | 0000, 0001 hex | 1 (See note 3.) | Span adjustment mode 0: 1/1,000 1: 1/10,000 |

- Note**
- The ERC indicator on the Unit's front panel will light if an out-of-range setting is made in either Setting Group 1 or 2. The offset from word m to the first word containing the out-of-range error will be stored as the Address of Data Range Error in the DM Area in four digits hexadecimal.
 - The operation settings are shown in the following table.

| Word | Bits | Description | Settings |
|------|------|---|---|
| m+18 | 00 | Temperature unit setting | 0: °C 1: °F |
| | 04 | Data format | 0: Binary (Negative values are given as 2's complements). 1: BCD |
| | 08 | Minus sign display format for BCD display | 0: "F" used to indicate the minus sign. 1: Leftmost bit used to indicate the minus sign. The setting is disabled if bits 04 to 07 are set to 0. |
| | 12 | Data direction at sensor error | 0: Goes to upper limit at sensor error 1: Goes to lower limit at sensor error |

Example:

For a temperature in degrees Celsius (°C), a binary data format, and a data direction at sensor error of "lower limit," word m+18 contains 1000.

- Indicates the value after transferring the default value (set when 12345 is written to word m).

CIO Area Allocations

First word: word n. n = 2000 + unit number × 10 (unit number: 0 to 95)

| Direction | Word | Bit | Name | | Data range | Contents |
|---|----------|-----------|-------------|--|---------------------------|--|
| Resistance Thermometer Input Unit to CPU Unit | n | 00 | Input No. 1 | Process value L (low limit) alarm | 0, 1 | 0: Process value > Set value 1: Process value ≤ Set value |
| | | 01 | | Process value H (high limit) alarm | 0, 1 | 0: Process value < Set value 1: Process value ≥ Set value |
| | | 02 | Input No. 2 | Process value L (low limit) alarm | 0, 1 | Same as for input No. 1. |
| | | 03 | | Process value H (high limit) alarm | 0, 1 | |
| | | 04 | Input No. 3 | Process value L (low limit) alarm | 0, 1 | |
| | | 05 | | Process value H (high limit) alarm | 0, 1 | |
| | | 06 | Input No. 4 | Process value L (low limit) alarm | 0, 1 | |
| | | 07 | | Process value H (high limit) alarm | 0, 1 | |
| | 08 to 15 | Not used. | | | | |
| | n + 1 | 00 to 15 | Input No. 1 | Process value | Depends on type of input. | |
| | n + 2 | 00 to 15 | Input No. 2 | | | |
| | n + 3 | 00 to 15 | Input No. 3 | | | |
| | n + 4 | 00 to 15 | Input No. 4 | | | |
| | n + 5 | Not used. | | | | |
| | n + 6 | | | | | |
| n + 7 | | | | | | |
| n + 8 | | | | | | |
| Resistance Thermometer Input Unit to CPU Unit | n + 9 | 00 | Input No. 1 | Sensor error | 0, 1 | 0: Normal 1: Error |
| | | 01 | Input No. 2 | | 0, 1 | |
| | | 02 | Input No. 3 | | 0, 1 | |
| | | 03 | Input No. 4 | | 0, 1 | |
| | 04 to 14 | Not used. | | | | |
| | 15 | 15 | | Conversion data enabled flag (See note.) | 0, 1 | 0: Data disabled 1: Data enabled |

Note The Conversion Data Enabled Flag remains OFF after the PLC is turned ON or the Unit is restarted until the AD conversion data becomes stable (approximately 2 to 4 s), then is ON during operation.

Terminal Connection Diagram

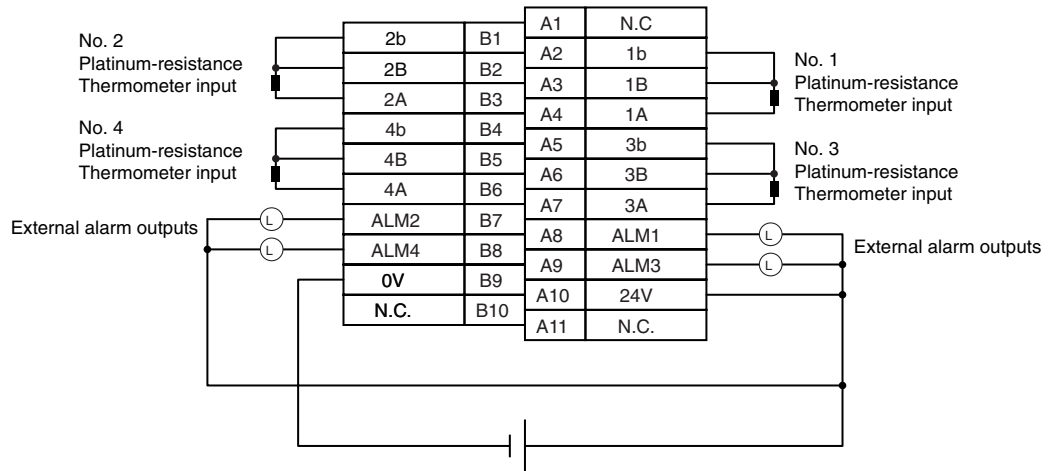

- Note**
- Wire the same length to A, B, and b, so that the impedance will be the same. In particular, do not short circuit between B and b at the terminal block.
 - For unused input terminals, connect approximately 100 Ω between the platinum-resistance thermometer input terminals A and B and short terminals B and b with a lead wire. If resistance is not connected between terminals A and B and terminals B and b are shorted or if terminals A and B and terminals B and b are left open, the alarm output will turn ON and the ALM indicator will light.
 - Do not connect anything to NC terminals. Do not use NC terminals as relay terminals.
 - Always ground the GR terminal on the Power Supply Unit of the PLC.
 - If the input device uses a voltage generator, temperature compensator, or similar device, then ground the input device if it has a ground terminal.

Terminal Block Diagram

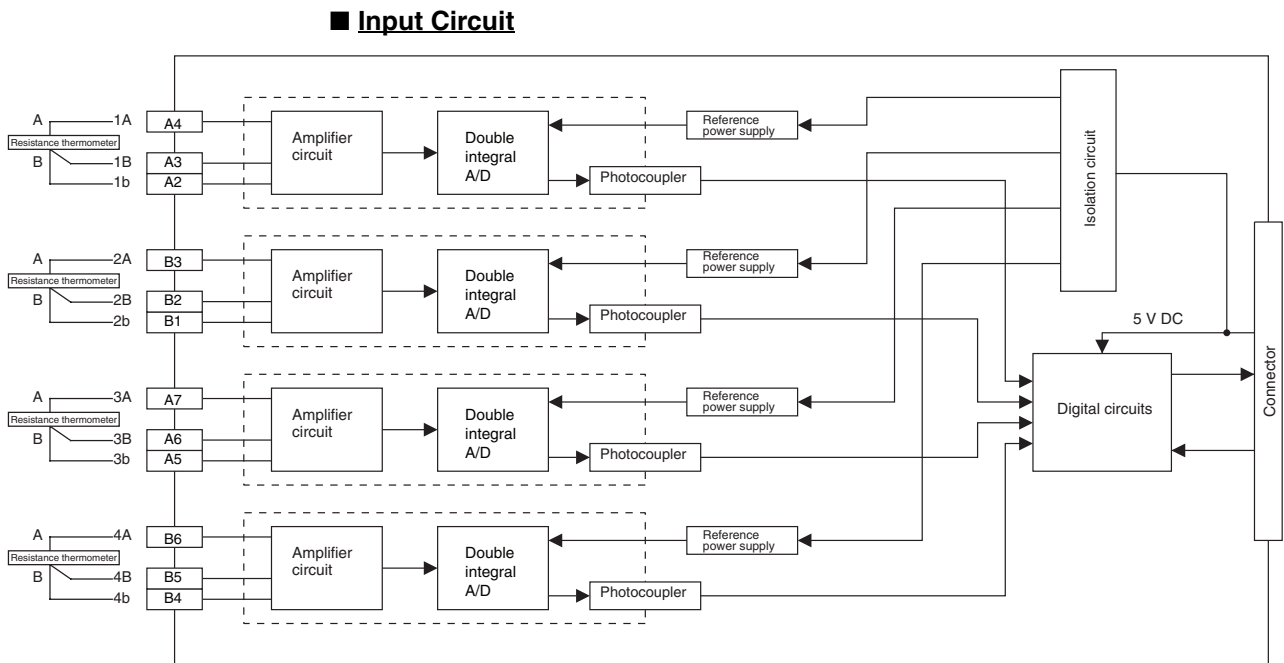

■ **Output Circuit**

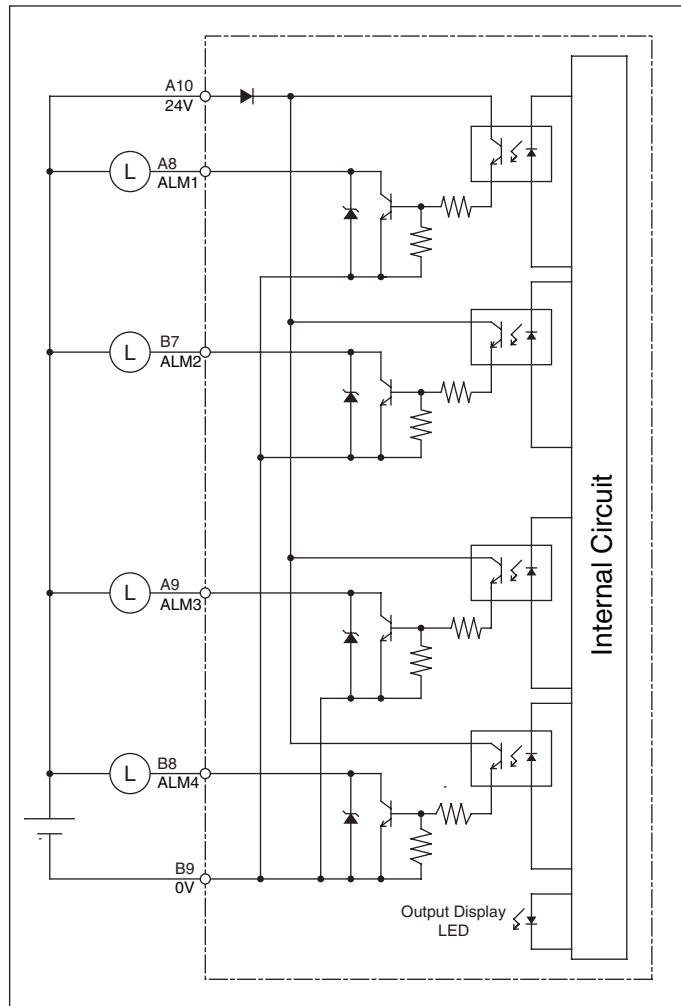

Error Processing

Conversion Data Does Not Change.

| Probable cause | Remedy |
|---|--|
| The gain for span adjustment is set to 0. | Set the gain for span adjustment to a value other than 0. |
| The sensor type is not set correctly. | Check and reset the sensor type. |
| An input device is malfunctioning, input wiring is faulty, or wiring is disconnected. | Check whether the resistance has changed. Check for faulty or disconnected wiring. Check whether a sensor error has been detected in the I/O Area. |

Values are Not Converted as Intended.

| Probable cause | Remedy |
|---|--|
| The sensor type is set incorrectly. | Check and reset the sensor type. |
| The zero/span adjustment data is incorrect. | Check and correct the zero/span adjustment settings. |

| Probable cause | Remedy |
|---|---------------------------------------|
| The platinum-resistance thermometer input wiring is faulty. | Check and correct the input wiring. |
| The compensating conductor is too long and measurements are being affected by conductor resistance. | Use a thicker compensating conductor. |

Converted Values are Unstable.

| Probable cause | Remedy |
|---|---|
| Input signals are being affected by external noise. | Change the connection paths of the input signal lines. (Separate them from sources of noise or use shielded cable.) |

2-9 CS1W-PTS56 Isolated-type Resistance Thermometer Input Unit (Pt100, JPt100)

Overview

The CS1W-PTS56 Isolated-type Resistance Thermometer Input Unit provides 8 direct platinum resistance thermometer inputs, and sends the data to the CPU Unit each cycle. All inputs are isolated.

CS1W-PTS56

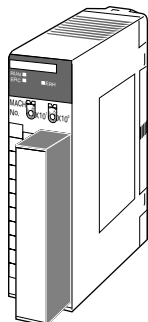

System Configuration

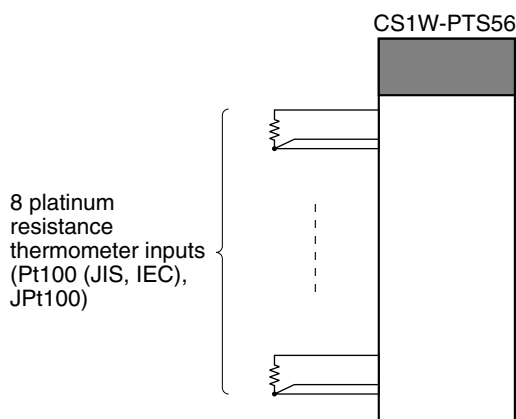

Features

- Up to 8 platinum resistance thermometers can be connected for each Unit (with 8 separate settings for temperature sensors and input ranges).
- Pt100 (JIS, IEC), JPt100 can be selected.
- Temperature sensor values are transmitted to the CPU Unit in four digits hexadecimal. (Either binary or BCD data output can be selected.)
- Process value alarms (Two internal alarms per input can be output to memory and two alarms per input can be output to specified I/O memory area addresses using indirect address specifications).
- Alarm ON-delay timer and hysteresis for process value.
- Zero/span adjustment capability during operation.
- Sensor error detection.
- Maximum or minimum process value can be specified for when a sensor error is detected.

Model Information

| Unit classification | Model number | Inputs | Input types |
|----------------------------|--------------|--------|--|
| CS-series Special I/O Unit | CS1W-PTS56 | 8 | Platinum resistance thermometer Pt100 (JIS, IEC), JPt100 |

Block Diagram (Order of Processing)

The processing for the inputs is as shown in the following diagram.

CPU Unit

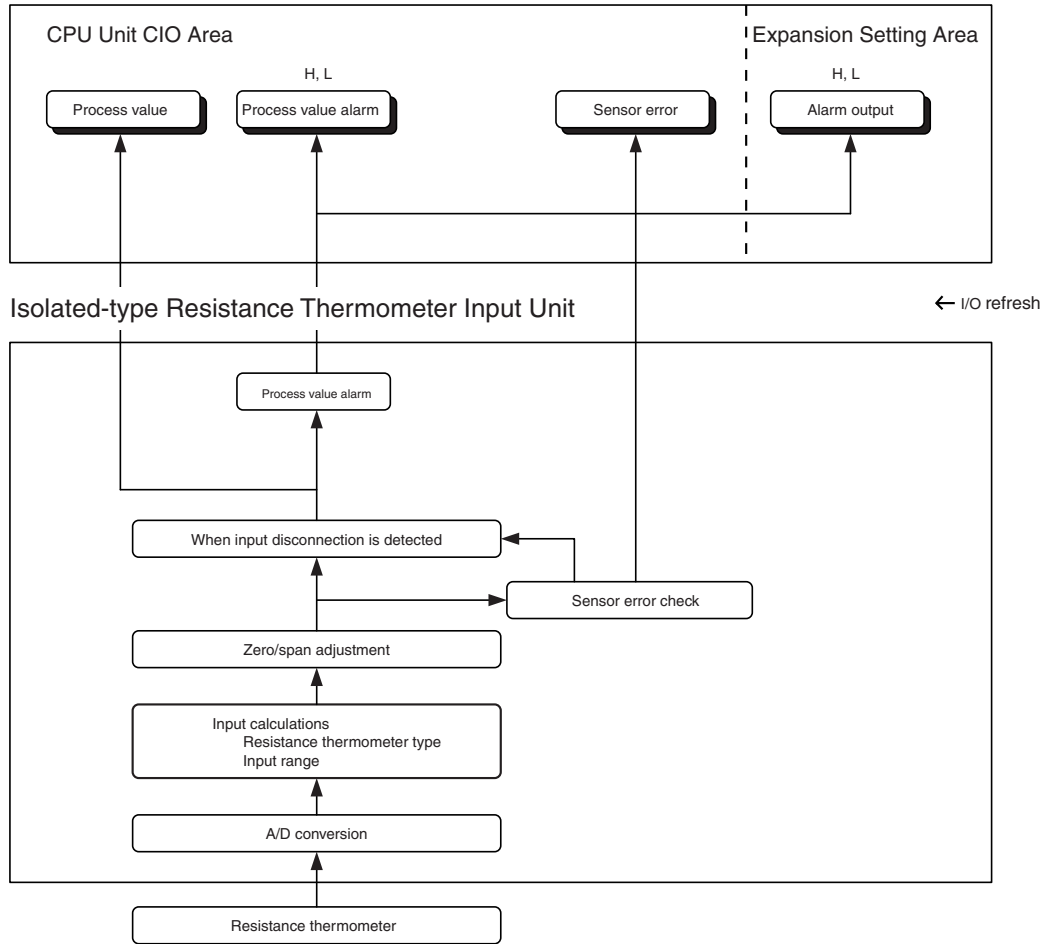

Specifications

| Item | Specifications | |
|---------------------------------------|---|--|
| Model | CS1W-PTS56 | |
| Applicable PLC | CS Series | |
| Unit classification | CS-series Special I/O Unit | |
| Mounting position | CS-series CPU Rack or CS-series Expansion Rack (Cannot be mounted to C200H Expansion I/O Rack or SYSMAC BUS Remote I/O Slave Rack.) | |
| Maximum number of Units | 80 (within the allowable current consumption and power consumption range) | |
| Unit numbers | 00 to 95 (Cannot duplicate Special I/O Unit numbers.) | |
| Areas for data exchange with CPU Unit | Special I/O Unit Area | 10 words/Unit Resistance Thermometer Input Unit to CPU Unit: All process values, process value alarms (L, H), conversion data enabled flag, sensor errors. |
| | DM Area words allocated to Special I/O Units | 100 words/Unit CPU Unit to Resistance Thermometer Input Unit: Temperature sensor type, input range (user set), process value alarm setting (L, H), zero/span adjustment value. |
| | Expansion Setting Area | 1 word/Unit CPU Unit to Resistance Thermometer Input Unit: Process Value Alarm |

| Item | | Specifications |
|--|---------------------|---|
| Number of temperature sensor inputs | | 8 |
| Temperature sensor type | | Pt100 (JIS, IEC), JPt100 The same sensor type, input range, and scaling to industrial units are used by all inputs. |
| Data storage in the CIO Area | | The actual process data in the input range is stored in four digits hexadecimal (binary or BCD values) in the allocated words in the CIO Area. |
| Accuracy (25°C) | | ±0.3% of PV or ±0.8°C, whichever is greater, ±1 digit max. (±0.3% of PV or ±1.6°F, whichever is greater, ±1 digit max.) PV: Process value data |
| Temperature characteristics | | Refer to <i>Temperature Characteristics According to Platinum Resistance Thermometer Type</i> on page 161. |
| Sensing method | | 3-wire method |
| Influence of conductor resistance | | 0.4°C/Ω max. |
| Input detection current | | 0.5 mA |
| Warmup time | | 10 min |
| Conversion period | | 250 ms/8 inputs |
| Maximum time to store data in CPU Unit | | Conversion period + one CPU Unit cycle |
| Sensor error detection | | Detects sensor error at each input and turns ON the Sensor error Flag. Hardware detection time: Approx. 0.5 s max. The process value overrange direction for when a sensor error occurs can be specified. (High: +20 digit of set input range; low: -20 digit of set input range) |
| Function | Process value alarm | Process value 2-point alarm (H, L), alarm hysteresis, and ON-delay timer (0 to 60 s are available). Two alarms per input (H, L) can be output to addresses in the CIO Area specified in the Expansion Setting Area. |
| Isolation | | Between inputs and PLC signal: Transformer for power supply and photocoupler for signals Between each input: Transformer for power supply and photocoupler for signals |
| Insulation resistance | | 20 MΩ max. (at 500 V DC). Between all input terminals and external AC terminals (Power Supply Unit) Between all input terminals and FG plate |
| Dielectric strength | | Between all input terminals and external AC terminals (Power Supply Unit) Between all input terminals and FG plate 1,000 V AC, 50/60 Hz 1 min., detection current: 1 mA Between all channels 500 VAC, 50/60 Hz 1 min., detection current: 1 mA |
| External connections | | Terminal block (detachable) |
| Unit number settings | | Set by rotary switches on front panel, from 0 to 95. |
| Indicators | | Three LED indicators on front panel (for normal operation, errors detected at the Unit, errors detected at the CPU Unit) |
| Effect on CPU Unit cycle time | | 0.4 ms |
| Current consumption | | 5 V DC at 180 mA max. 26 V DC at 60 mA max. |
| Dimensions | | 35 × 130 × 126 mm (W × H × D) Note The height including the Backplane is 145 mm. |
| Weight | | 450 g max. |

Sensor Type and Input Range

The Platinum Resistance Thermometer type and input range are set in the allocated words in the DM Area for every four inputs.

The measurable data range is ±20 digits wider than the sensor input range.

| Set-ting | Input | °C | | | °F | | |
|----------|--|---|---|------------------------------------|--|--|--|
| | | 16-bit binary | BCD | | 16-bit binary | BCD | |
| | | | F□□□ indicates minus sign. | Leftmost bit indicates minus sign. | | Leftmost 4 bits (bits 12 to 15) indicate minus sign. | Leftmost bit (bit 15) indicates minus sign. |
| 0 | Pt100: -200.0 to 650.0°C (-300.0 to 1200.0°F) | F830 to FFFF to 1964 (-200.0 to -0.1 to 650.0) | F999 to 6500 (See note 2.) (-99.9 to 650.0) | A000 to 6500 (-200.0 to 650.0) | F448 to FFFF to 2EE0 (-300.0 to -0.1 to 1200.0) | F999 to 9999 (See note 2.) (-99.9 to 999.9) | B000 to 7999 (See note 2.) (-300.0 to 799.9) |
| 1 | JPt100: -200.0 to 650.0°C (-300.0 to 1200.0°F) | F830 to FFFF to 1964 (-200.0 to -0.1 to 650.0) | F999 to 6500 (See note 2.) (-99.9 to 650.0) | A000 to 6500 (-200.0 to 650.0) | F448 to FFFF to 2EE0 (-300.0 to -0.1 to 1200.0) | F999 to 9999 (See note 2.) (-99.9 to 999.9) | B000 to 7999 (See note 2.) (-300.0 to 799.9) |
| 2 to 9 | Do not set. | | | | Do not set. | | |

- Note**
- If the indication range is exceeded, a sensor error will occur and the sensor error bit will turn ON. The process value will be clamped at the lower or upper limit of the indication range, depending on the setting for data direction at sensor error.
 - The indicator range for BCD display will be clamped at the lower (or upper) limit in the region between the lower (or upper) limit of the setting range and the point where a sensor error occurs.
 For 0.1°C/0.1°F indication with minus sign indicated by leftmost 4 bits (bits 12 to 15): Lower limit = -99.9, Upper limit = 999.9.
 For 0.1°C/0.1°F indication with minus sign indicated by leftmost bit (bit 15): Lower limit = -799.9, Upper limit = 799.9.

Temperature Characteristics According to Platinum Resistance Thermometer Type

| Platinum Resistance Thermometer | Temperature range | Set value error when ambient temperature changes by 1°C |
|---------------------------------|-------------------|---|
| Pt100 | -200 to 200°C | ±0.06°C |
| | 200 to 650°C | 285 ppm of PV |
| JPt100 | -200 to 200°C | ±0.06°C |
| | 200 to 650°C | 285 ppm of PV |

The measured temperature error is calculated as shown in the following example.

| Item | Details |
|---------------------------------|---|
| Ambient temperature | 30°C |
| Platinum Resistance Thermometer | Pt100 |
| Measured temperature (PV) | 500°C |
| Reference accuracy (25°C) | ±0.3°C of PV or ±0.8°C, whichever is greater, ±1 digit. In this example, ±1.5°C. |
| Temperature characteristics | 200 to 650°C: 285 ppm of PV. In this example, 285 ppm × 500°C = 0.143°C. |
| Change in ambient temperature | 5°C (25 to 30°C) |

Overall accuracy =
 Reference accuracy + Temperature characteristic × Change in ambient temperature = ±1.5°C + ±0.143°C × 5 = Approx. ± 2.2°C ±1 digit.

DM Area Allocations

First word: word m. m = D20000 + unit number × 100 (unit number: 0 to 95)

| DM Area address | | | | | | | | Data range | | Default | Data contents |
|--|-------------|-------------|-------------|-------------|-------------|-------------|-------------|-----------------------------------|----------------------|---|---|
| Input No. 1 | Input No. 2 | Input No. 3 | Input No. 4 | Input No. 5 | Input No. 6 | Input No. 7 | Input No. 8 | Decimal | Hexadecimal | | |
| m | | | | | | | | 12345, 0 | 3039, 0000 hex | 0000 hex | Default block read command Specifies the direction of data transfer when the PLC is turned ON or the Unit is restarted for DM Area words m+1 to m+60. <ul style="list-style-type: none"> 12345 (3039 hex): The data in words m+1 to m+60 is transferred from the Resistance Thermometer Input Unit to the CPU Unit. When the transfer is completed, the value will become 0000 hex. Other than 12345 (3039 hex) (such as 0000 hex): The data in the allocated words of DM Area is transferred from the CPU Unit to the Resistance Thermometer Input Unit. |
| Display parameter | | | | | | | | | | | |
| m+1 | | | | | | | | 0 to 59 | 0000 to 003B hex | 0 (0000 hex) | Address of Data Range Error (See note 1.) |
| Setting Group 1 (continuously refreshed area): Parameters that are continuously refreshed during PLC operation (regardless of the CPU Unit's operation mode) | | | | | | | | | | | |
| | | | | | | | | | | Process value alarm settings | |
| m+2 | m+6 | m+10 | m+14 | m+18 | m+22 | m+26 | m+30 | Low to high limit for all sensors | | 6500 (1964 hex) | Process value H (high limit) alarm setting |
| m+3 | m+7 | m+11 | m+15 | m+19 | m+23 | m+27 | m+31 | | | -2000 (F830 hex) | Process value L (low limit) alarm setting |
| Span adjustment value | | | | | | | | | | | |
| m+4 | m+8 | m+12 | m+16 | m+20 | m+24 | m+28 | m+32 | 0 to 32000 | 0000 to 7D00 hex | 10000 (2710 hex) | Set value × 0.0001 |
| Zero adjustment value | | | | | | | | | | | |
| m+5 | m+9 | m+13 | m+17 | m+21 | m+25 | m+29 | m+33 | -9999 to 9999 | D8F1 to 270F hex | 0 (0000 hex) | Set value × 0.1 |
| Setting Group 2 (initial settings area): Parameters that are transferred one time from the CPU Unit to the Resistance Thermometer Input Unit if word m contains other than 12345 when the PLC is turned ON or the Resistance Thermometer Input Unit is restarted. | | | | | | | | | | | |
| | | | | | | | | | | Operation settings (See note 2.) | |
| m +34 | | | | | | | | (See note 2.) | (See note 2.) | 0 (0000 hex) | 00 to 03: Temperature unit (°C or °F) 04 to 07: Data display (binary or BCD) 08 to 11: Minus sign display format for BCD display 12 to 15: Data direction at sensor error |
| Sensor type | | | | | | | | | | | |
| m+35 | m+38 | m+41 | m+44 | m+47 | m+50 | m+53 | m+56 | 0, 1, 15 | 0000, 0001, 000F hex | 0 (0000 hex) | 0: Pt100; 1: JPt100, F: Not used |
| Alarm hysteresis | | | | | | | | | | | |
| m+36 | m+39 | m+42 | m+45 | m+48 | m+51 | m+54 | m+57 | 0 to 9999 | 0000 to 270F hex | 0 (0000 hex) | Set value × 0.1 |
| Alarm ON-delay time | | | | | | | | | | | |
| m+37 | m+40 | m+43 | m+46 | m+49 | m+52 | m+55 | m+58 | 0 to 60 | 0000 to 003C hex | 0 (0000 hex) | Unit: s |
| Expansion Setting Area enable | | | | | | | | | | | |
| m+59 | | | | | | | | 0, 1 | 0000, 0001 hex | 0 (0000 hex) | 0: Disabled 1: Enabled |

| DM Area address | | | | | | | | Data range | | Default | Data contents |
|----------------------|-------------|-------------|-------------|-------------|-------------|-------------|-------------|------------|------------------|-----------------|---------------------------------------|
| Input No. 1 | Input No. 2 | Input No. 3 | Input No. 4 | Input No. 5 | Input No. 6 | Input No. 7 | Input No. 8 | Decimal | Hexadecimal | | |
| | | | | | | | | | | | Expansion Setting Area address |
| m+60 (See note 3) | | | | | | | | 0 to 6143 | 0000 to 17FF hex | 0 (0000 hex) | CIO area (fixed) Number of words. |

- Note**
1. The ERC indicator on the Unit's front panel will light if an out-of-range setting is made in either Setting Group 1 or 2. The offset from word m to the first word containing the out-of-range error will be stored as the Address of Data Range Error in the DM Area in four digits hexadecimal.
 2. The operation settings are shown in the following table.
 3. A range check is not performed for the Expansion Setting Area address set in word m+60. Be sure to check this address before starting actual operation.

| Word | Bits | Description | Settings |
|------|------|---|---|
| m+34 | 00 | Temperature unit setting | 0: °C 1: °F |
| | 04 | Data format | 0: Binary (Negative values are given as 2's complements). 1: BCD |
| | 08 | Minus sign display format for BCD display | 0: "F" used to indicate the minus sign. 1: Leftmost bit used to indicate the minus sign. The setting is disabled if bits 04 to 07 are set to 0. |
| | 12 | Data direction at sensor error | 0: Goes to upper limit at sensor error 1: Goes to lower limit at sensor error |

Example: For a temperature in degrees Celsius (°C), a binary data format, and a data direction at sensor error of "lower limit," word m+18 contains 1000.

Expansion Setting Area

First word: word o. (o = address specified in word m+60 in the DM Area)

| Direction | Word | Bit | Name | | Data range | Contents |
|---|------|-----|-------------|------------------------------------|------------|--|
| Resistance Thermometer Input Unit to CPU Unit | o | 00 | Input No. 1 | Process value L (low limit) alarm | 0, 1 | 0: Process value > Set value 1: Process value ≤ Set value |
| | | 01 | | Process value H (high limit) alarm | 0, 1 | 0: Process value < Set value 1: Process value ≥ Set value |
| | | 02 | Input No. 2 | Process value L (low limit) alarm | 0, 1 | Same as for input No. 1. |
| | | 03 | | Process value H (high limit) alarm | 0, 1 | |
| | | 04 | Input No. 3 | Process value L (low limit) alarm | 0, 1 | |
| | | 05 | | Process value H (high limit) alarm | 0, 1 | |
| | | 06 | Input No. 4 | Process value L (low limit) alarm | 0, 1 | |
| | | 07 | | Process value H (high limit) alarm | 0, 1 | |
| | | 08 | Input No. 5 | Process value L (low limit) alarm | 0, 1 | |
| | | 09 | | Process value H (high limit) alarm | 0, 1 | |
| | | 10 | Input No. 6 | Process value L (low limit) alarm | 0, 1 | |
| | | 11 | | Process value H (high limit) alarm | 0, 1 | |
| | | 12 | Input No. 7 | Process value L (low limit) alarm | 0, 1 | |
| | | 13 | | Process value H (high limit) alarm | 0, 1 | |
| | | 14 | Input No. 8 | Process value L (low limit) alarm | 0, 1 | |
| | | 15 | | Process value H (high limit) alarm | 0, 1 | |

Note If either of the following changes is made for the Expansion Setting Area for the CS1W-PTS55/PTS56/PDC55, the previous data will be left in the Expansion Setting Area even after the change has been made.
Clear the previous data when changing either of these settings.

- The Expansion Setting Area Enable setting is changed from “enabled” to “disabled.”
- The Expansion Setting Area Address setting is changed while the Expansion Setting Area Enable setting is set to “enabled.”

CIO Area Allocations

First word: word n. n = 2000 + unit number × 10 (unit number: 0 to 95)

| Direction | Word | Bit | Name | | Data range | Contents |
|---|----------|------------------------------------|--|------------------------------------|-------------------------------------|--|
| Resistance Thermometer Input Unit to CPU Unit | n | 00 | Input No. 1 | Process value L (low limit) alarm | 0, 1 | 0: Process value > Set value 1: Process value ≤ Set value |
| | | 01 | | Process value H (high limit) alarm | 0, 1 | 0: Process value < Set value 1: Process value ≥ Set value |
| | | 02 | Input No. 2 | Process value L (low limit) alarm | 0, 1 | Same as for input No. 1. |
| | | 03 | | Process value H (high limit) alarm | 0, 1 | |
| | | 04 | Input No. 3 | Process value L (low limit) alarm | 0, 1 | |
| | | 05 | | Process value H (high limit) alarm | 0, 1 | |
| | | 06 | Input No. 4 | Process value L (low limit) alarm | 0, 1 | |
| | | 07 | | Process value H (high limit) alarm | 0, 1 | |
| | | 08 | Input No. 5 | Process value L (low limit) alarm | 0, 1 | |
| | | 09 | | Process value H (high limit) alarm | 0, 1 | |
| | | 10 | Input No. 6 | Process value L (low limit) alarm | 0, 1 | |
| | | 11 | | Process value H (high limit) alarm | 0, 1 | |
| | | 12 | Input No. 7 | Process value L (low limit) alarm | 0, 1 | |
| | | 13 | | Process value H (high limit) alarm | 0, 1 | |
| | | 14 | Input No. 8 | Process value L (low limit) alarm | 0, 1 | |
| | 15 | Process value H (high limit) alarm | | 0, 1 | | |
| | n + 1 | 00 to 15 | Input No. 1 | Process value | Depends on type of input. | |
| | n + 2 | 00 to 15 | Input No. 2 | | | |
| | n + 3 | 00 to 15 | Input No. 3 | | | |
| | n + 4 | 00 to 15 | Input No. 4 | | | |
| n + 5 | 00 to 15 | Input No. 5 | | | | |
| n + 6 | 00 to 15 | Input No. 6 | | | | |
| n + 7 | 00 to 15 | Input No. 7 | | | | |
| n + 8 | 00 to 15 | Input No. 8 | | | | |
| Resistance Thermometer Input Unit to CPU Unit | n + 9 | 00 | Input No. 1 | Sensor error | 0, 1 | 0: Normal 1: Error |
| | | 01 | Input No. 2 | | 0, 1 | |
| | | 02 | Input No. 3 | | 0, 1 | |
| | | 03 | Input No. 4 | | 0, 1 | |
| | | 04 | Input No. 5 | | 0, 1 | |
| | | 05 | Input No. 6 | | 0, 1 | |
| | | 06 | Input No. 7 | | 0, 1 | |
| | | 07 | Input No. 8 | | 0, 1 | |
| | 08 to 14 | Not used | | | | |
| | 15 | 15 | Conversion data enabled flag (See note.) | 0, 1 | 0: Data disabled 1: Data enabled | |

Note The Conversion Data Enabled Flag remains OFF after the PLC is turned ON or the Unit is restarted until the AD conversion data becomes stable (approximately 2 to 4 s), then is ON during operation.

Terminal Connection Diagram

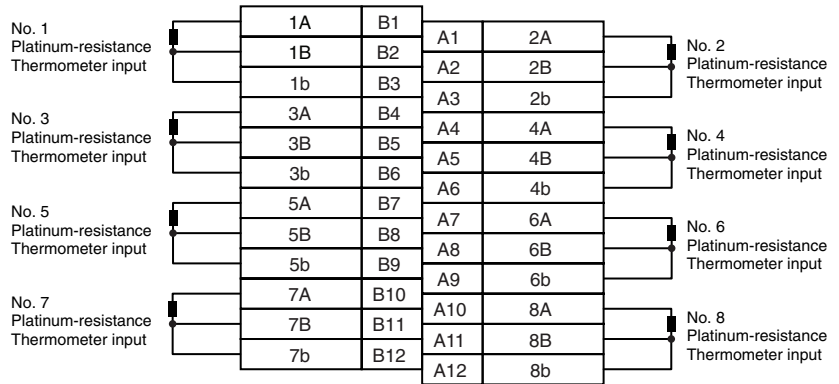

Note

- Wire the same length to A, B, and b, so that the impedance will be the same. In particular, do not short circuit between B and b at the terminal block.
- Set the *Sensor type* in Setting Group 2 in the DM Area to “Not used” for any thermocouple inputs that are not used.
- Always ground the GR terminal on the Power Supply Unit of the PLC.
- If the input device uses a voltage generator, temperature compensator, or similar device, then ground the input device if it has a ground terminal.

Terminal Block Diagram

Input Circuit

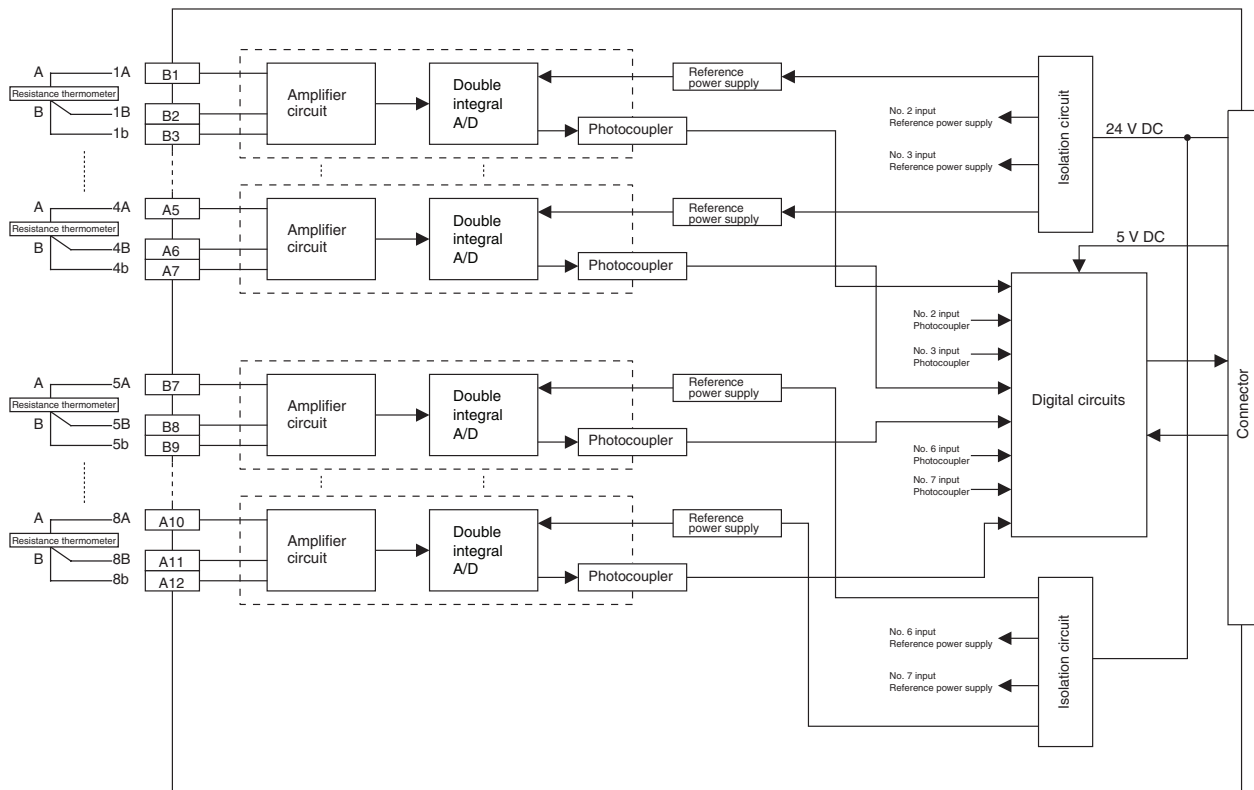

Error Processing

Conversion Data Does Not Change.

| Probable cause | Remedy |
|---|--|
| The gain for span adjustment is set to 0. | Set the gain for span adjustment to a value other than 0. |
| The sensor type is not set correctly. | Check and reset the sensor type. |
| An input device is malfunctioning, input wiring is faulty, or wiring is disconnected. | Check whether the resistance has changed. Check for faulty or disconnected wiring. Check whether a sensor error has been detected in the I/O Area. |

Values are Not Converted as Intended.

| Probable cause | Remedy |
|---|---|
| The sensor type, or input range is set incorrectly. | Check and reset the sensor type, input range, and the process value scaling settings. |
| The zero/span adjustment data is incorrect. | Check and correct the zero/span adjustment settings. |
| The platinum-resistance thermometer input wiring is faulty. | Check and correct the input wiring. |
| The compensating conductor is too long and measurements are being affected by conductor resistance. | Use a thicker compensating conductor. |

Converted Values are Unstable.

| Probable cause | Remedy |
|---|---|
| Input signals are being affected by external noise. | Change the connection paths of the input signal lines. (Separate them from sources of noise or use shielded cable.) |

2-10 CS1W-PTW01 2-Wire Transmitter Input Unit

Overview

The CS1W-PTW01 2-Wire Transmitter Input Unit provides up to four inputs for unified signals (4 to 20 mA) from a transmitter, with no external DC power supply, and sends the data to the CPU Unit each cycle.

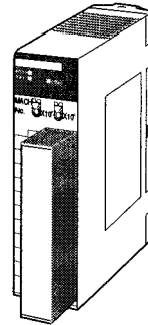

CS1W-PTW01

System Configuration

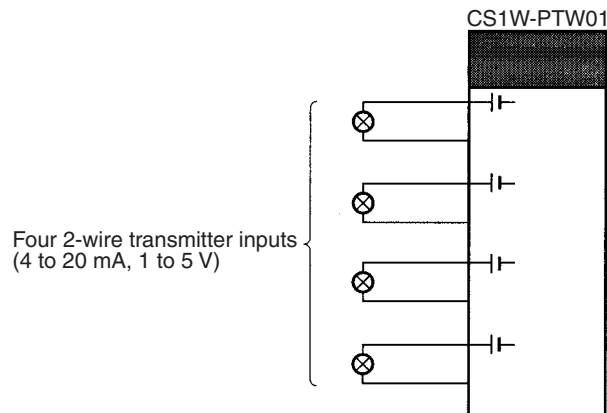

Features

- Up to four inputs can be connected per Unit for unified signals from a 2-wire transmitter, such as pressure, differential pressure, etc.
- A built-in power supply (24 V DC) for a 2-wire transmitter for each input eliminates the need for an external power supply.
- Inputs of 4 to 20 mA and 1 to 5 V, are possible with no need to provide the usual DC power supply.
- Scaling values are sent to the CPU Unit in four digits hexadecimal.
- Square root function.
- Four values for each process value alarm input.
- ON-delay timer for process value alarm.
- Mean value processing.
- Rate-of-change calculation.
- Two values for each rate-of-change alarm input.
- Input error detection.
- Zero/span adjustment capability during operation.

Model Information

| Unit classification | Model number | Inputs | Input types |
|----------------------------|--------------|--------|---|
| CS-series Special I/O Unit | CS1W-PTW01 | 4 | From transmitter: unified signal (4 to 20 mA) or 4 to 20 mA, 1 to 5 V |

Block Diagram (Order of Processing)

The processing for the four inputs is as shown in the following diagram.

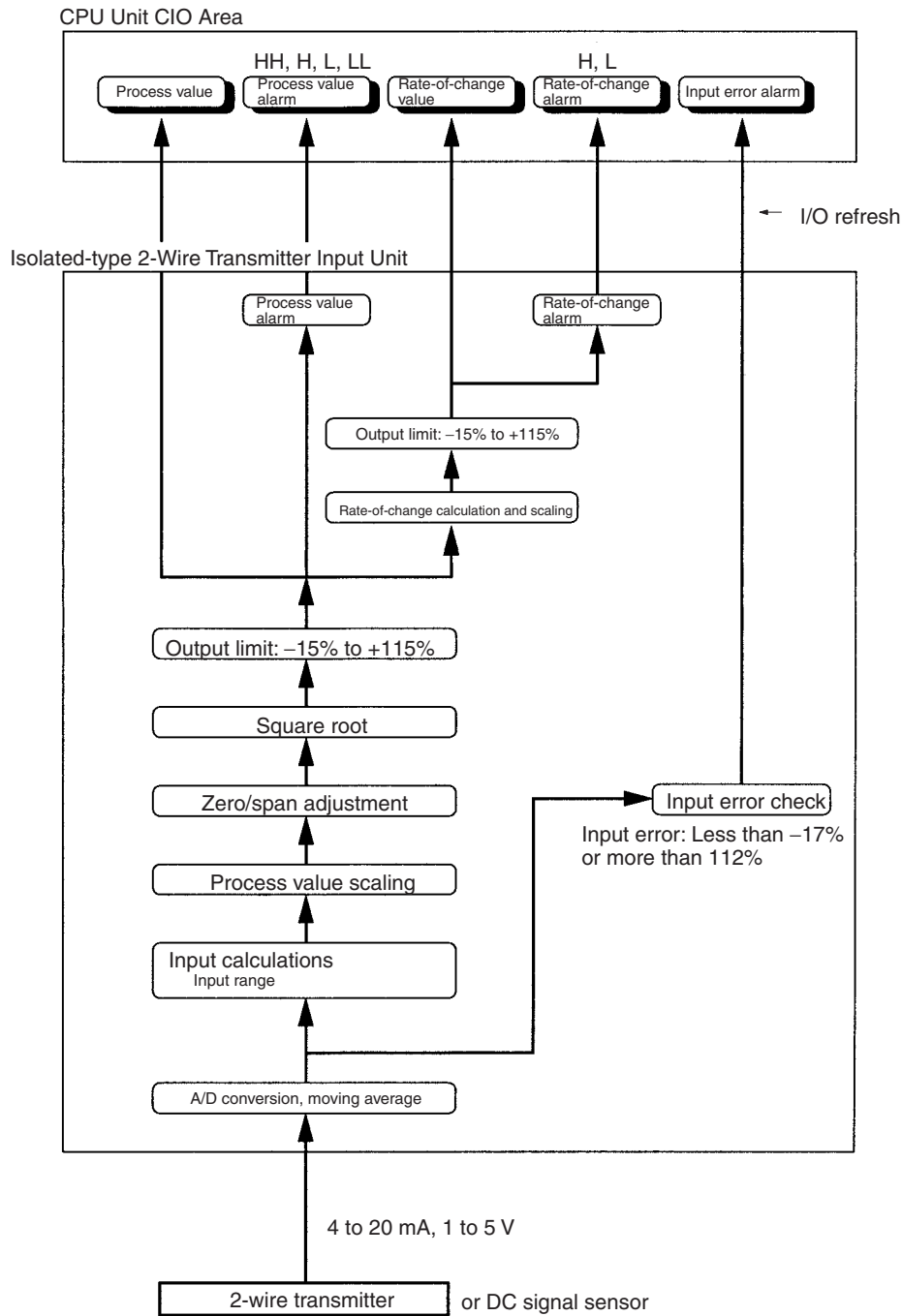

Specifications

| Item | Specifications |
|-------------------------|---|
| Model | CS1W-PTW01 |
| Applicable PLC | CS Series |
| Unit classification | CS-series Special I/O Unit |
| Mounting position | CS-series CPU Rack or CS-series Expansion Rack (Cannot be mounted to C200H Expansion I/O Rack or SYSMAC BUS Remote I/O Slave Rack.) |
| Maximum number of Units | 80 (within the allowable current consumption and power consumption range) |
| Unit numbers | 00 to 95 (Cannot duplicate Special I/O Unit numbers.) |

| Item | | Specifications |
|--|--|--|
| Areas for data exchange with CPU Unit | Special I/O Unit Area | 10 words/Unit 2-Wire Transmitter Input Unit to CPU Unit: All process values, process value alarms (LL, L, H, HH), rate-of-change values, rate-of-change alarms (L, H), input errors |
| | DM Area words allocated to Special I/O Units | 100 words/Unit CPU Unit to 2-Wire Transmitter Input Unit: Sensor type, scaling of process value data to be stored in allocated words in CIO area, square root function enable, rate-of-change value range, rate-of-change scaling, number of items for moving average, process value alarm setting (LL, L, H, HH), rate-of-change alarm setting (L, H), zero/span adjustment value, etc. |
| Number of inputs | 4 | |
| Sensor type | Unified signal from transmitter (4 to 20 mA), 4 to 20 mA, 1 to 5 V | Sensor type and scaling to industrial units are separate for each of the 4 inputs. |
| User-defined scaling in industrial units | Scaling required for 4 to 20 mA or 1 to 5 V. (Any minimum and maximum values can be set.) (4 inputs set separately.) | Note Sensor type and scaling to industrial units are set in the DM Area. Example: Input signal type: 4 to 20 mA from 2-wire transmitter; industrial unit scaling: 0 to 500 m ³ /h (after square root extraction). DM Area settings are as follows: Input signal type: 0 (0000 hex) Industrial unit maximum value stored: 500 (01F4 hex) Industrial unit minimum value stored: 0 (0000 hex) |
| Data storage in the CIO Area | The value derived from carrying out the following processing in order of the process value data is stored in four digits hexadecimal (binary values) in the allocated words in the CIO Area. 1) Mean value processing → 2) Scaling → 3) Zero/span adjustment → 4) Square root extraction → 5) Output limits | |
| Accuracy (25°C) | ±0.2% of full scale | |
| Temperature coefficient | ±0.015%/°C of full scale | |
| Resolution | 1/4,096 of full scale | |
| Input signal range | -15 to 115% | |
| Power supply for 2-wire transmitter | Output voltage: 24 V DC ±15% for each input (without load) Current capacity: 22 mA max. for each input Short-circuit control current: 22 to 27 mA Allowable short-circuit time: Ambient temperature less than 40°C: No limit Ambient temperature 40 to 55°C: 10 min or less | |
| Input impedance | 4 to 20 mA for 2-wire transmitter: 250 Ω; 4 to 20 mA: 250 Ω; 1 to 5 V: 1 MΩ min. | |
| Warmup time | 10 min | |
| Response time | 0.5 s (travel time from input 0% to 90%, for step input) | |
| Conversion period | 100 ms/4 inputs | |
| Maximum time to store data in CPU Unit | Conversion period + one CPU Unit cycle | |
| Input error detection | Error detected when under -17.2% (4 to 20 mA: 1.25 mA; 1 to 5 V: 0.3125 V) or over 112.5% (4 to 20 mA: 22 mA; 1 to 5 V: 5.5 V). | |
| Operation at input disconnection | Process value of -15% stored. | |
| Input disconnection overrange time | Approx. 1 s | |

| Item | | Specifications |
|-------------------------------|---|--|
| Function | Mean value processing (input filter) | Calculates the moving average for the specified number of process values (1 to 16), and stores that value in the CIO Area as the process value. |
| | Process value alarm | Process value 4-point alarm (HH, H, LL, L), alarm hysteresis, and ON-delay timer (0 to 60 s) are available. |
| | Rate-of-change calculation | Calculates the amount of change per comparison time interval (1 to 16 s). |
| | Rate-of-change alarm | Rate-of-change 2-point alarm (H, L), alarm hysteresis (shared with process value alarm), and ON-delay timer (0 to 60 s, shared with process value alarm) are available. |
| | Square root | <p>When the process value scaling maximum value is A and the minimum value is B:</p> $\text{Output} = \sqrt{(A-B) (\text{Input}-B)} + B$ <p>Dropout: Output approx. 7% maximum linear (output = input) characteristics</p> <p>Note 1 The square root function is only enabled when the maximum scaling value is greater than the minimum value.</p> <p>Note 2 When square root processing is being performed, set the maximum and minimum scaling values to the values required after square root processing of the current or other input values.</p> |
| Isolation | Between inputs and between input terminals and PLC signals: Isolation by transformer | |
| Insulation resistance | 20 MΩ (at 500 V DC) between inputs | |
| Dielectric strength | Between inputs: 1,000 V AC, at 50/60 Hz, for 1 min, leakage current 10 mA max. | |
| External connections | Terminal block (detachable) | |
| Unit number settings | Set by rotary switches on front panel, from 0 to 95. | |
| Indicators | Three LED indicators on front panel (for normal operation, errors detected at the 2-Wire Transmitter Input Unit, and errors related to the CPU Unit). | |
| Front panel connector | Sensor input connector terminal block (detachable) | |
| Effect on CPU Unit cycle time | 0.3 ms | |
| Current consumption | 5 V DC at 150 mA max., 26 V DC at 160 mA max. | |
| Dimensions | 35 × 130 × 126 mm (W × H × D) Note The height including the Backplane is 145 mm. | |
| Weight | 450 g max. | |
| Standard accessories | None | |

DM Area Allocations

m = D20000 + unit number × 100 (unit number: 0 to 95)

| Input No. 1 | Input No. 2 | Input No. 3 | Input No. 4 | Decimal | Hexadecimal | Default | Data contents |
|--|-------------|-------------|-------------|-----------------|------------------------------------|------------------|--|
| m | | | | 12345, 0 | 3039, 0000 hex | 0000 hex | Default block read command Specifies the direction of data transfer when the PLC is turned ON or the Unit is restarted for DM words m+2 to m+81. <ul style="list-style-type: none"> 12345 (3039 hex): The data in words m+2 to m+81 is transferred from the 2-Wire Transmitter Input Unit to the CPU Unit. When the transfer is completed, the value will become 0000 hex. Other than 12345 (3039 hex) (such as 0000 hex): The data in the allocated words of DM Area is transferred from the CPU Unit to the 2-Wire Transmitter Input Unit. |
| Setting Group 1 (continuously refreshed area): Parameters that are continuously refreshed during PLC operation (regardless of the CPU Unit's operation mode) | | | | | | | |
| | | | | | | | Process value alarm settings |
| m + 2 | m + 10 | m + 18 | m + 26 | -32768 to 32767 | 8000 to FFFF hex, 0000 to 7FFF hex | 4200 (1068 hex) | Process value HH (high high limit) alarm setting (Set at process value scaling value.) |
| m + 3 | m + 11 | m + 19 | m + 27 | -32768 to 32767 | 8000 to FFFF hex, 0000 to 7FFF hex | 4000 (0FA0 hex) | Process value H (high limit) alarm setting (Set at process value scaling value.) |
| m + 4 | m + 12 | m + 20 | m + 28 | -32768 to 32767 | 8000 to FFFF hex, 0000 to 7FFF hex | 0 (0000 hex) | Process value L (low limit) alarm setting (Set at process value scaling value.) |
| m + 5 | m + 13 | m + 21 | m + 29 | -32768 to 32767 | 8000 to FFFF hex, 0000 to 7FFF hex | -200 (FF38 hex) | Process value LL (low low limit) alarm setting (Set at process value scaling value.) |
| | | | | | | | Rate-of-change value alarm settings |
| m + 6 | m + 14 | m + 22 | m + 30 | -32768 to 32767 | 8000 to FFFF hex, 0000 to 7FFF hex | 4000 (0FA0 hex) | Rate-of-change value H (high limit) alarm setting (Set at rate-of-change scaling value.) |
| m + 7 | m + 15 | m + 23 | m + 31 | -32768 to 32767 | 8000 to FFFF hex, 0000 to 7FFF hex | 0 (0000 hex) | Rate-of-change value L (low limit) alarm setting (Set at rate-of-change scaling value.) |
| | | | | | | | Zero/span adjustment |
| m + 8 | m + 16 | m + 24 | m + 32 | 0 to 32000 | 0000 to 7D00 hex | 10000 (2710 hex) | Gain for span adjustment (set value × 0.0001) |
| m + 9 | m + 17 | m + 25 | m + 33 | -32000 to 32000 | 8300 to FFFF hex, 0000 to 7D00 hex | 0 (0000 hex) | Zero adjustment value (Set at process value scaling value.) |
| Setting Group 2 (initial settings area): Parameters that are transferred one time from the CPU Unit to the 2-Wire Transmitter Input Unit if word m contains other than 12345 when the PLC is turned ON or the 2-Wire Transmitter Input Unit is restarted. | | | | | | | |
| m + 34 | m + 46 | m + 58 | m + 70 | 0, 1 | 0000 to 0001 hex | 0 (0000 hex) | Input signal type 0: 4 to 20 mA, 1: 1 to 5 V |
| m + 35 | m + 47 | m + 59 | m + 71 | 0, 1 | 0000 to 0001 hex | 0 (0000 hex) | Square root extraction 0: Disable; 1: Enable |
| | | | | | | | Process value scaling |
| m + 36 | m + 48 | m + 60 | m + 72 | -32000 to 32000 | 8300 to FFFF hex, 0000 to 7D00 hex | 4000 (0FA0 hex) | Value stored for maximum value in range (span) |
| m + 37 | m + 49 | m + 61 | m + 73 | -32000 to 32000 | 8300 to FFFF hex, 0000 to 7D00 hex | 0 (0000 hex) | Value stored for minimum value in range (zero) |
| | | | | | | | Alarm supplementary functions |
| m + 38 | m + 50 | m + 62 | m + 74 | 0 to 32000 | 0000 to 7D00 hex | 40 (0028 hex) | Alarm hysteresis (Set at process value scaling value. Shared with process value alarm and rate-of-change alarm.) |
| m + 39 | m + 51 | m + 63 | m + 75 | 0 to 60 | 0000 to 003C hex | 0 (0000 hex) | Alarm ON-delay time (Unit: s) (Shared with process value alarm and rate-of-change alarm.) |

| Input No. 1 | Input No. 2 | Input No. 3 | Input No. 4 | Decimal | Hexadecimal | Default | Data contents | |
|--------------------------|-------------|-------------|-------------|-----------------|------------------------------------|------------------|---|--|
| | | | | | | | Rate-of-change function | |
| m + 40 | m + 52 | m + 64 | m + 76 | -32000 to 32000 | 8300 to FFFF hex, 0000 to 7D00 hex | 4000 (0FA0 hex) | Rate-of-change range setting | Maximum rate-of-change value (Process value industrial unit; comparison time interval) |
| m + 41 | m + 53 | m + 65 | m + 77 | -32000 to 32000 | 8300 to FFFF hex, 0000 to 7D00 hex | -4000 (F060 hex) | | Minimum rate-of-change value (Process value industrial unit; comparison time interval) |
| m + 42 | m + 54 | m + 66 | m + 78 | 1 to 16 | 0001 to 0010 hex | 01 (0001 hex) | Rate-of-change comparison time interval (Unit: s) | |
| m + 43 | m + 55 | m + 67 | m + 79 | -32000 to 32000 | 8300 to FFFF hex, 0000 to 7D00 hex | 4000 (0FA0 hex) | Rate-of-change value scaling | Value stored for maximum value in range |
| m + 44 | m + 56 | m + 68 | m + 80 | -32000 to 32000 | 8300 to FFFF hex, 0000 to 7D00 hex | 0 (0000 hex) | | Value stored for minimum value in range |
| | | | | | | | Mean value processing function | |
| m + 45 | m + 57 | m + 69 | m + 81 | 1 to 16 | 0001 to 0010 hex | 4 (0004 hex) | Number of process values for calculating moving average for mean value processing | |
| Storage parameter | | | | | | | | |
| m + 82 | m + 83 | m + 84 | m + 85 | 0 to 81 | 0000 to 0051 hex | 0 (0000 hex) | Address of Data Range Error (See note.) | |

Note The ERC indicator on the Unit's front panel will light if an out-of-range setting is made in either Setting Group 1 or 2. The offset from word m to the first word containing the out-of-range error will be stored as the Address of Data Range Error in the DM Area in four digits hexadecimal. For more information, refer to *1-6 Error Processing*.

CIO Area Allocations

n = 2000 + unit number × 10 (unit number: 0 to 95)

| Direction | Word | Bit | Name | | Data range | Contents |
|---|------|-----|-------------|--|------------|------------------------------|
| 2-Wire Transmitter Input Unit to CPU Unit | n | 00 | Input No. 1 | Process value LL (low low limit) alarm | 0, 1 | 0: Process value > Set value |
| | | 01 | | Process value L (low limit) alarm | 0, 1 | 1: Process value ≤ Set value |
| | | 02 | | Process value H (high limit) alarm | 0, 1 | 0: Process value < Set value |
| | | 03 | | Process value HH (high high limit) alarm | 0, 1 | 1: Process value ≥ Set value |
| | | 04 | Input No. 2 | Process value LL (low low limit) alarm | 0, 1 | Same as for input No. 1. |
| | | 05 | | Process value L (low limit) alarm | 0, 1 | |
| | | 06 | | Process value H (high limit) alarm | 0, 1 | |
| | | 07 | | Process value HH (high high limit) alarm | 0, 1 | |
| | | 08 | Input No. 3 | Process value LL (low low limit) alarm | 0, 1 | Same as for input No. 1. |
| | | 09 | | Process value L (low limit) alarm | 0, 1 | |
| | | 10 | | Process value H (high limit) alarm | 0, 1 | |
| | | 11 | | Process value HH (high high limit) alarm | 0, 1 | |
| | | 12 | Input No. 4 | Process value LL (low low limit) alarm | 0, 1 | Same as for input No. 1. |
| | | 13 | | Process value L (low limit) alarm | 0, 1 | |
| | | 14 | | Process value H (high limit) alarm | 0, 1 | |
| | | 15 | | Process value HH (high high limit) alarm | 0, 1 | |

| Direction | Word | Bit | Name | | Data range | Contents | |
|---|-------------------------|-------------------------|---|---|---|--|--|
| 2-Wire Transmitter Input Unit to CPU Unit | n + 1 | 00 to 15 | Input No. 1 process value | | -32768 to 32767 (8000 to FFFF hex, 0000 to 7FFF hex) | The present process value is stored according to the scaling set in the allocated words of the DM Area. | |
| | n + 2 | 00 to 15 | Input No. 2 process value | | -32768 to 32767 (8000 to FFFF hex, 0000 to 7FFF hex) | | |
| | n + 3 | 00 to 15 | Input No. 3 process value | | -32768 to 32767 (8000 to FFFF hex, 0000 to 7FFF hex) | | |
| | n + 4 | 00 to 15 | Input No. 4 process value | | -32768 to 32767 (8000 to FFFF hex, 0000 to 7FFF hex) | | |
| | n + 5 | 00 to 15 | Input No. 1 rate-of-change value | | -32768 to 32767 (8000 to FFFF hex, 0000 to 7FFF hex) | The process value rate of change is stored according to the scaling set in the allocated words of the DM Area. | |
| | n + 6 | 00 to 15 | Input No. 2 rate-of-change value | | -32768 to 32767 (8000 to FFFF hex, 0000 to 7FFF hex) | | |
| | n + 7 | 00 to 15 | Input No. 3 rate-of-change value | | -32768 to 32767 (8000 to FFFF hex, 0000 to 7FFF hex) | | |
| | n + 8 | 00 to 15 | Input No. 4 rate-of-change value | | -32768 to 32767 (8000 to FFFF hex, 0000 to 7FFF hex) | | |
| | n + 9 | 00 | Input No. 1 | Rate-of-change value L (low limit) alarm | | 0, 1 | 0: Rate-of-change value > Set value 1: Rate-of-change value ≤ Set value |
| | | | | Rate-of-change value H (high limit) alarm | | 0, 1 | 0: Rate-of-change value < Set value 1: Rate-of-change value ≥ Set value |
| | | 02 | Input No. 2 | Rate-of-change value L (low limit) alarm | | 0, 1 | Same as for input No. 1. |
| | | | | Rate-of-change value H (high limit) alarm | | 0, 1 | |
| 04 | | Input No. 3 | Rate-of-change value L (low limit) alarm | | 0, 1 | Same as for input No. 1. | |
| | | | Rate-of-change value H (high limit) alarm | | 0, 1 | | |
| 06 | | Input No. 4 | Rate-of-change value L (low limit) alarm | | 0, 1 | Same as for input No. 1. | |
| | | | Rate-of-change value H (high limit) alarm | | 0, 1 | | |
| 08 | | Input No. 1 input error | | | | 0, 1 | 0: Normal 1: Error (less than -17.2% or greater than 112.5%) |
| 09 | | Input No. 2 input error | | | | 0, 1 | Same as for input No. 1. |
| 10 | | Input No. 3 input error | | | | 0, 1 | Same as for input No. 1. |
| 11 | Input No. 4 input error | | | | 0, 1 | Same as for input No. 1. | |

Terminal Connection Diagram

2-Wire Transmitter Input

CS1W-PTW01 Isolated-type 2-Wire Transmitter Input Unit

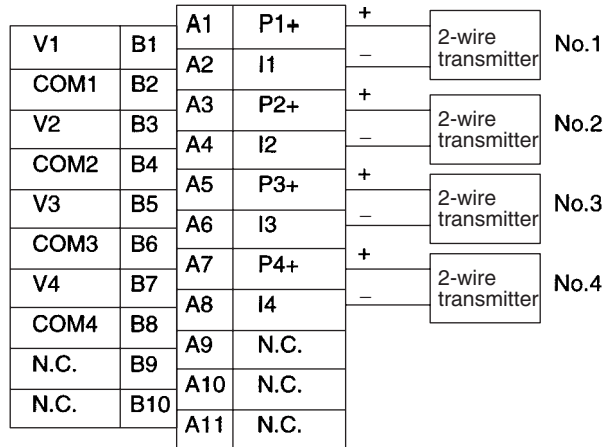

Current Input (No Power Supply Necessary)

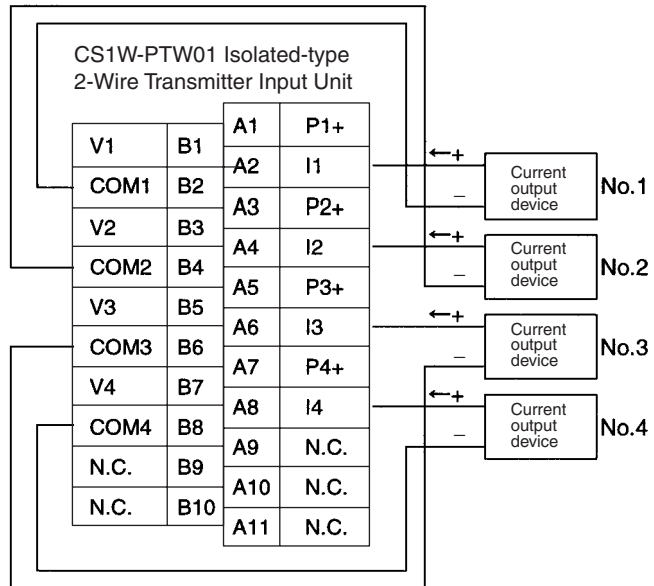

Voltage Input

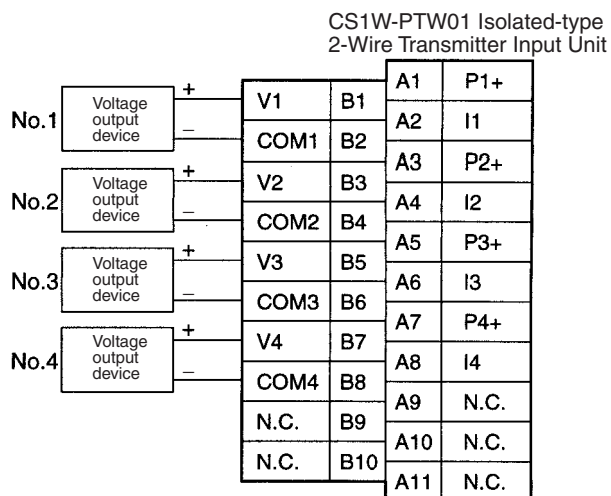

Note In all of the above cases, leave all unused terminals open (e.g., terminals A1, A2, B1, and B2 for input No. 1).

Terminal Block Diagram

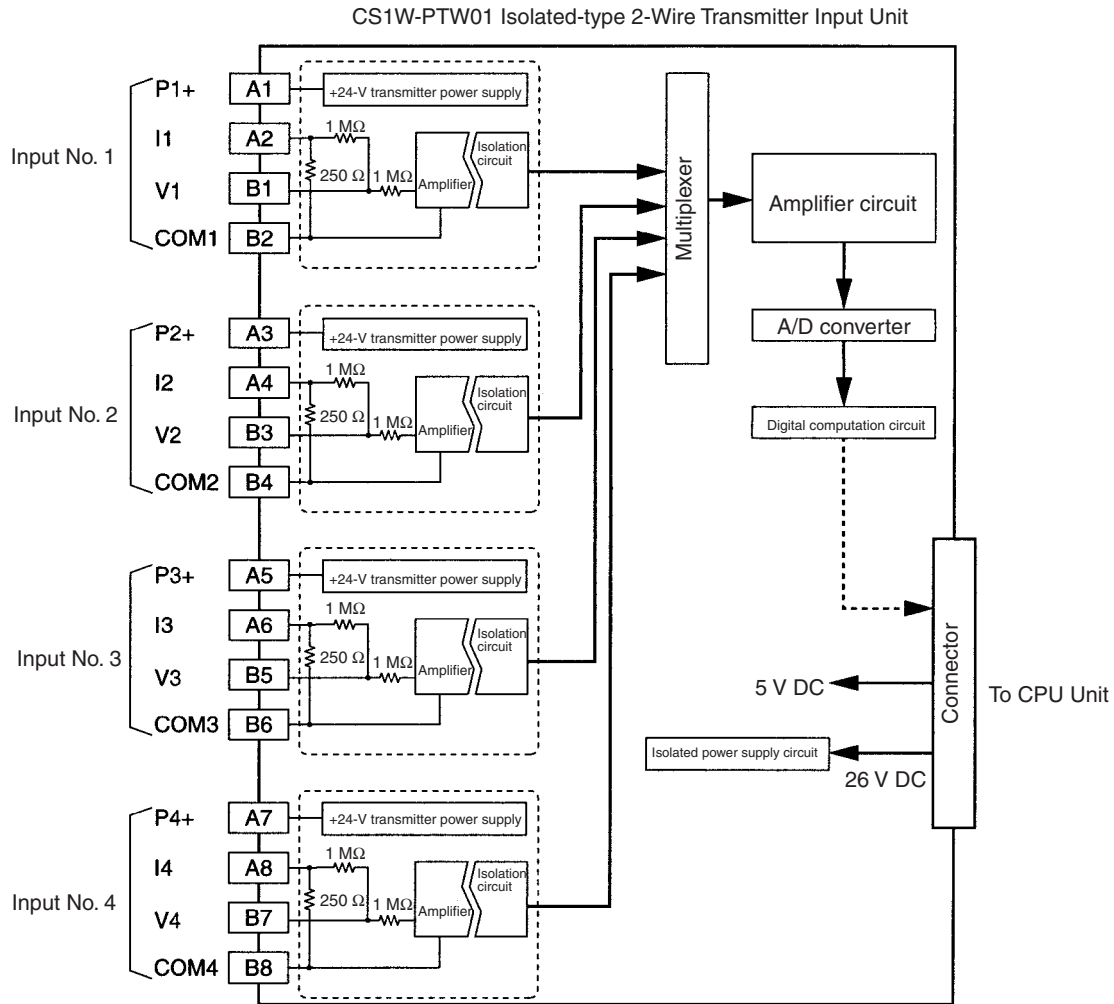

2-Wire Transmitter Input

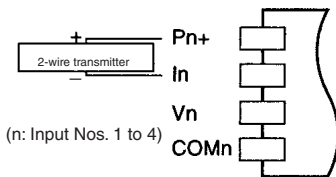

4-mA to 20-mA Input

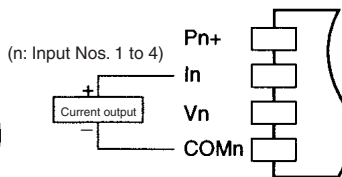

1-V to 5-V Input

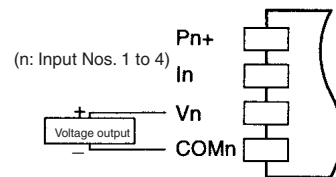

Error Processing

Conversion Data Does Not Change.

| Probable cause | Remedy |
|--|---|
| The gain for span adjustment is set to 0. | Set the gain for span adjustment to a value other than 0. |
| The minimum and maximum values for process value scaling are either the same or are set extremely low. | Set the minimum and maximum values correctly. |
| The input signal type or process value scaling is set incorrectly. | Check and reset the input signal type and the process value scaling settings. |
| An input device is malfunctioning, input wiring is faulty, or wiring is disconnected. | Check whether the input voltage has changed. Check for faulty or disconnected wiring. Check whether an input error has been detected in the I/O Area. |

Values are Not Converted as Intended.

| Probable cause | Remedy |
|--|---|
| The input signal type or process value scaling is set incorrectly. | Check and reset the input signal type and the process value scaling settings. |
| The zero/span adjustment data is incorrect. | Check and correct the zero/span adjustment settings. |
| The square root function is operating. | Set the square function so that it does not operate. |

Converted Values are Unstable.

| Probable cause | Remedy |
|--|---|
| Input signals are being affected by external noise. | Change the connection paths of the input signal lines. (Separate them from sources of noise or use shielded cable.) |
| | Insert 0.01- μ F to 0.1- μ F ceramic capacitors between the I+ and COM, and between the V+ and COM input terminals. |
| | Increase the number of values for calculating the moving average in mean value processing. |
| The scaling value is greater than the Unit's resolution. | Reduce the scaling value. |

2-11 CS1W-PDC01 Isolated-type Direct Current Input Unit

Overview

The CS1W-PDC01 Isolated-type Direct Current Input Unit provides four DC signal inputs, and sends the data to the CPU Unit each cycle. All inputs are isolated.

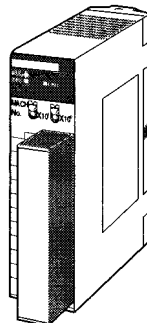

CS1W-PDC01

System Configuration

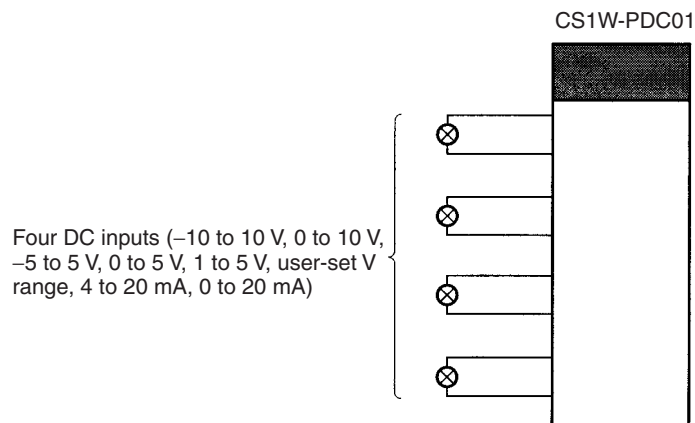

Features

- Up to four DC signal inputs can be connected per Unit. Any of the following can be selected separately for the four inputs: 4 to 20 mA, 0 to 20 mA, -10 to 10 V, 0 to 10 V, -5 to 5 V, 1 to 5 V, 0 to 5 V, or ± 10 -V user-set range.
- Scaling values are sent to the CPU Unit in four digits hexadecimal.
- Isolation between analog inputs can prevent sneak circuits from occurring between input signals.
- Square root function.
- Four values for each process value alarm input.
- ON-delay timer for process value alarm.
- Mean value processing.
- Rate-of-change calculation.
- Two values for each rate-of-change alarm input.
- Input error detection.
- Zero/span adjustment capability during operation.

Model Information

| Unit classification | Model number | Inputs | Input types |
|----------------------------|--------------|--------|--|
| CS-series Special I/O Unit | CS1W-PDC01 | 4 | The following can be selected separately: 4 to 20 mA, 0 to 20 mA, -10 to 10 V, 0 to 10 V, -5 to 5 V, 1 to 5 V, 0 to 5 V, or ± 10 -V user-set range |

Block Diagram (Order of Processing)

The processing for the four inputs is as shown in the following diagram.

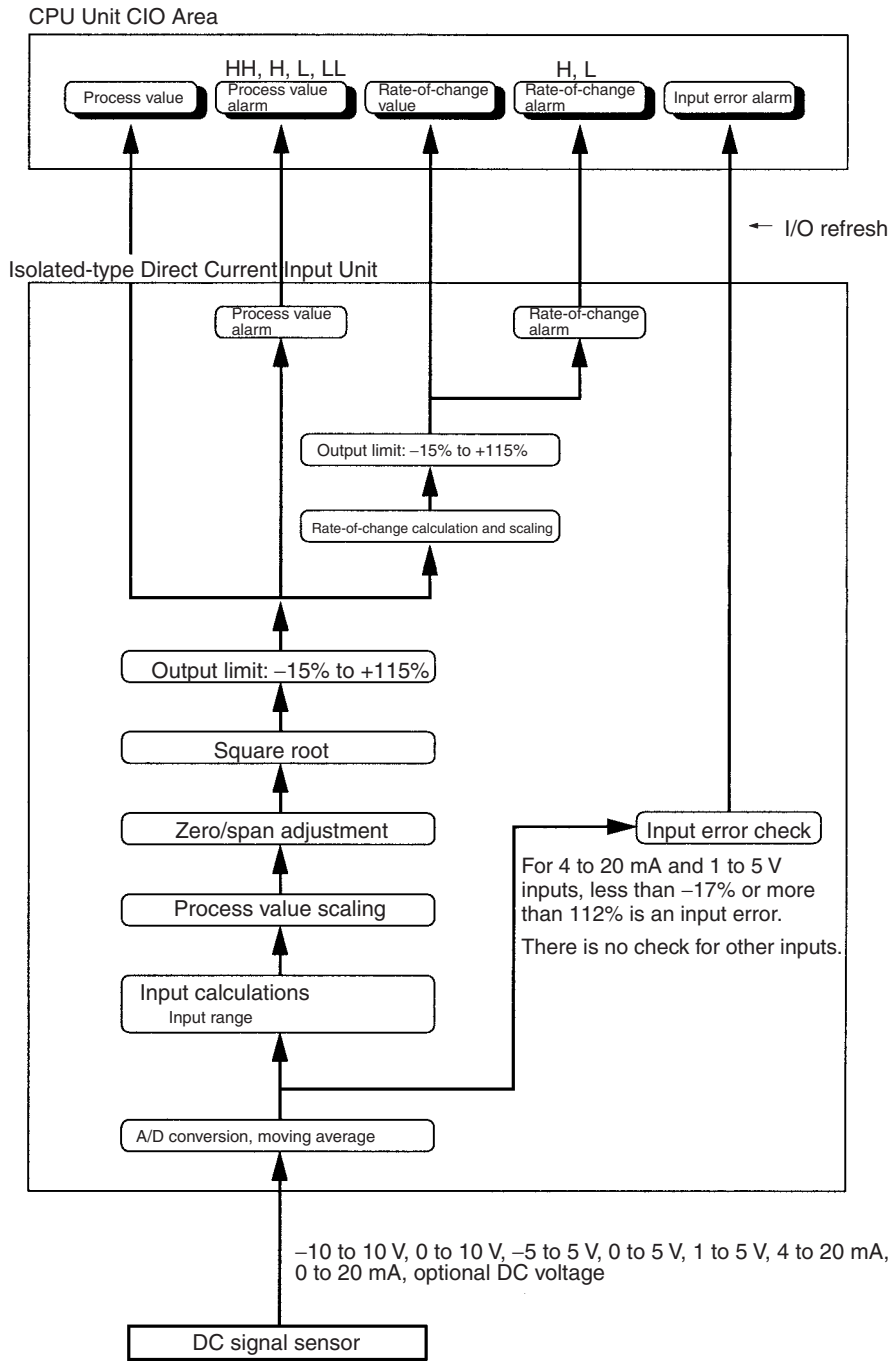

Specifications

| Item | | Specifications |
|--|--|--|
| Model | | CS1W-PDC01 |
| Applicable PLC | | CS-series |
| Unit classification | | CS-series Special I/O Unit |
| Mounting position | | CS-series CPU Rack or CS-series Expansion Rack (Cannot be mounted to C200H Expansion I/O Rack or SYSMAC BUS Remote I/O Slave Rack.) |
| Maximum number of Units | | 80 (within the allowable current consumption and power consumption range) |
| Unit numbers | | 00 to 95 (Cannot duplicate Special I/O Unit numbers.) |
| Areas for data exchange with CPU Unit | Special I/O Unit Area | 10 words/Unit Isolated-type Direct Current Input Unit to CPU Unit: All process values, process value alarms (LL, L, H, HH), rate-of-change values, rate-of-change alarms (L, H), input errors |
| | DM Area words allocated to Special I/O Units | 100 words/Unit CPU Unit to Isolated-type Direct Current Input Unit: Input signal type, scaling of process values in industrial units, square root function enable, rate-of-change value range, rate-of-change scaling, number of items for moving average, process value alarm setting (LL, L, H, HH), rate-of-change alarm setting (L, H), zero/span adjustment value, etc. |
| Number of inputs | | 4 |
| Input signal type | | 4 to 20 mA, 0 to 20 mA, -10 to 10 V, 0 to 10 V, -5 to 5 V, 1 to 5 V, 0 to 5 V, or ±10-V user-set range. The ±10-V user-set range can be specified within -10.000 to 10.000 V. |
| User-defined scaling in industrial units | | Scaling required for the above input signals, such as 4 to 20 mA or 1 to 5 V. (Any minimum and maximum values can be set.) (4 inputs set separately.) |
| Data storage in the CIO Area | | The value derived from carrying out the following processing in order of the process value data is stored in four digits hexadecimal (binary values) in the allocated words in the CIO Area. 1) Mean value processing → 2) Scaling → 3) Zero/span adjustment → 4) Square root extraction → 5) Output limits |
| Accuracy (25°C) | | ±0.1% of full scale For the ±10-V user-set range, however, as shown in the following equation, the accuracy depends on the ratio of the selected internal range (0 to 4) span to the user-set range span. $\text{Accuracy} = \pm 0.1\% \times \frac{\text{Internal range span}}{\text{User-set range span}}$ |
| Temperature coefficient | | ±0.015% /°C with respect to full scale. For the ±10-V user-set range, however: ±0.015% /°C with respect to the internal range. |
| Resolution | | 1/4,096 of full scale For the ±10-V user-set range, however, as shown in the following equation, the resolution depends on the ratio of the selected internal range (0 to 4) span to the user-set range span. $\text{Resolution} = \frac{1}{4096} \times \frac{\text{Internal range span}}{\text{User-set range span}}$ |
| Input signal range | | For inputs of 4 to 20 mA, 0 to 20 mA, 0 to 10 V, 1 to 5 V, 0 to 5 V: -15 to 115% For inputs of -10 to 10 V or -5 to 5 V: -7.5 to 107.5% For ±10-V user-set range: -7.5 to 107.5% of internal range |
| Input impedance | | For current input: 250 Ω For voltage input: 1 MΩ min. |

| Item | | Specifications |
|--|--------------------------------------|--|
| Warmup time | | 10 min |
| Response time | | 0.5 s (travel time from input 0% to 90%, for step input) |
| Conversion period | | 100 ms/4 inputs |
| Maximum time to store data in CPU Unit | | Conversion period + one CPU Unit cycle |
| Input error detection | | Checks are conducted for only 4 to 20 mA and 1 to 5 V. Error detected when under -17.2% (1.25 mA, 0.3125 V) or over 112.5% (22 mA, 5.5 V). |
| Operation at input disconnection | | 4 to 20 mA, 1 to 5 V: Process value of -15% stored. 0 to 20 mA, 0 to 5 V, 0 to 10 V, -10 to 10 V: The same value is stored as when 0 V or 0 mA is input. |
| Input disconnection overrange time | | Approx. 1 s |
| Function | Mean value processing (input filter) | Calculates the moving average for the specified number of past process values (1 to 16), and stores that value in the CIO Area as the process value. |
| | Process value alarm | Process value 4-point alarm (HH, H, L, LL), hysteresis, and ON-delay timer (0 to 60 s) are available. |
| | Rate-of-change calculation | Calculates the amount of change per comparison time interval (1 to 16 s). |
| | Rate-of-change alarm | Rate-of-change 2-point alarm (H, L), alarm hysteresis (shared with process value alarm), and ON-delay timer (0 to 60 s, shared with process value alarm) are available. |
| | Square root | When the process value scaling maximum value is A and the minimum value is B: Output = $\sqrt{(A-B) (\text{Input}-B)}$ +B Dropout: Output approx. 7% maximum linear (output = input) characteristics Note The square root function is only enabled when the maximum scaling value is greater than the minimum value. Note When square root processing is being performed, set the maximum and minimum scaling values to the values required after square root processing of the current or other input values. |
| Isolation | | Between analog inputs and between input terminals and PLC signals: Isolation by transformer |
| Insulation resistance | | 20 MΩ (at 500 V DC) between inputs |
| Dielectric strength | | Between inputs: 1,000 V AC, at 50/60 Hz, for 1 min, leakage current 10 mA max. |
| External connections | | Terminal block (detachable) |
| Unit number settings | | Set by rotary switches on front panel, from 0 to 95. |
| Indicators | | Three LED indicators on front panel (for normal operation, errors detected at the Direct Current Input Unit, and errors related to the CPU Unit). |
| Front panel connector | | Sensor input connector terminal block (detachable) |
| Effect on CPU Unit cycle time | | 0.3 ms |
| Current consumption | | 5 V DC at 150 mA max., 26 V DC at 160 mA max. |
| Dimensions | | 35 × 130 × 126 mm (W × H × D) Note The height including the Backplane is 145 mm. |
| Weight | | 450 g max. |
| Standard accessories | | None |

Accuracy and Resolution for ±10 V User-set Range

With the ±10-V user-set range, the input signal zero and span can be set anywhere within the range -10.000 to 10.000 V. Internally, however, inputs are processed in five progressive ranges (numbers 0 to 4), as shown in the following table.

Table 1: Internal Ranges

| Internal range number | Measurable voltage | Internal range span |
|-----------------------|---------------------|---------------------|
| 0 | -10.000 to 10.000 V | 20.000 V |
| 1 | -5.000 to 5.000 V | 10.000 V |
| 2 | -2.500 to 2.500 V | 5.000 V |
| 3 | -1.250 to 1.250 V | 2.500 V |
| 4 | -0.625 to 0.625 V | 1.250 V |

Therefore, the accuracy and resolution of the set range span are determined by the ratio of the internal range (0 to 4) span to the set input range span. For the internal range, a larger number is selected when both the minimum and maximum values of the range fall within that next range.

For example, suppose that the set input range is 0.000 to 3.000 V. Since both the minimum and maximum values fall within the limits for internal range No. 1 (-5.000 to 5.000 V), that range will be selected.

DM Area Allocations

$$m = D20000 + \text{unit number} \times 100 \text{ (unit number: 0 to 95)}$$

| Input No. 1 | Input No. 2 | Input No. 3 | Input No. 4 | Decimal | Hexadecimal | Default | Data contents |
|---|-------------|-------------|-------------|-----------------|------------------------------------|------------------|---|
| m | | | | 12345, 0 | 3039, 0000 hex | 0000 hex | Default block read command Specifies the direction of data transfer when the PLC is turned ON or the Unit is restarted for DM words m+2 to m+89. <ul style="list-style-type: none"> 12345 (3039 hex): The data in words m+2 to m+89 is transferred from the Direct Current Input Unit to the CPU Unit. When the transfer is completed, the value will become 0000 hex. Other than 12345 (3039 hex) (such as 0000 hex): The data in the allocated words of DM Area is transferred from the CPU Unit to the Direct Current Input Unit. |
| Setting Group 1 (continuously refreshed area): Parameters that are continuously refreshed during PLC operation (regardless of the CPU Unit's operation mode) | | | | | | | |
| | | | | | | | Process value alarm settings |
| m + 2 | m + 10 | m + 18 | m + 26 | -32768 to 32767 | 8000 to FFFF hex, 0000 to 7FFF hex | 4200 (1068 hex) | Process value HH (high high limit) alarm setting (Set at process value scaling value.) |
| m + 3 | m + 11 | m + 19 | m + 27 | -32768 to 32767 | 8000 to FFFF hex, 0000 to 7FFF hex | 4000 (0FA0 hex) | Process value H (high limit) alarm setting (Set at process value scaling value.) |
| m + 4 | m + 12 | m + 20 | m + 28 | -32768 to 32767 | 8000 to FFFF hex, 0000 to 7FFF hex | 0 (0000 hex) | Process value L (low limit) alarm setting (Set at process value scaling value.) |
| m + 5 | m + 13 | m + 21 | m + 29 | -32768 to 32767 | 8000 to FFFF hex, 0000 to 7FFF hex | -200 (FF38 hex) | Process value LL (low low limit) alarm setting (Set at process value scaling value.) |
| | | | | | | | Rate-of-change value alarm settings |
| m + 6 | m + 14 | m + 22 | m + 30 | -32768 to 32767 | 8000 to FFFF hex, 0000 to 7FFF hex | 4000 (0FA0 hex) | Rate-of-change value H (high limit) alarm setting (Set at rate-of-change scaling value.) |
| m + 7 | m + 15 | m + 23 | m + 31 | -32768 to 32767 | 8000 to FFFF hex, 0000 to 7FFF hex | 0 (0000 hex) | Rate-of-change value L (low limit) alarm setting (Set at rate-of-change scaling value.) |
| | | | | | | | Zero/span adjustment |
| m + 8 | m + 16 | m + 24 | m + 32 | 0 to 32000 | 0000 to 7D00 hex | 10000 (2710 hex) | Gain for span adjustment (set value x 0.0001) |
| m + 9 | m + 17 | m + 25 | m + 33 | -32000 to 32000 | 8300 to FFFF hex, 0000 to 7D00 hex | 0 (0000 hex) | Zero adjustment value (Set at process value scaling value.) |

| Input No. 1 | Input No. 2 | Input No. 3 | Input No. 4 | Decimal | Hexadecimal | Default | Data contents | |
|--|-------------|-------------|-------------|-----------------|------------------------------------|---------------------|---|--|
| Setting Group 2 (initial settings area): Parameters that are transferred one time from the CPU Unit to the Direct Current Input Unit if word m contains other than 12345 when the PLC is turned ON or the Direct Current Input Unit is restarted. | | | | | | | | |
| | | | | | | | Input signal type | |
| m + 34 | m + 48 | m + 62 | m + 76 | 0 to 7 | 0000 to 0007 hex | 1 (0001 hex) | Input signal type 0: -10 to 10 V, 1: 0 to 10 V, 2: -5 to 5 V, 3: 0 to 5 V, 4: 1 to 5 V, 5: 4 to 20 mA, 6: ±10-V user-set range (set to the range below), 7: 0 to 20 mA | |
| m + 35 | m + 49 | m + 63 | m + 77 | -10000 to 10000 | D8F0 to 2710 hex | 10000 (2710 hex) | ±10-V user-set range | Maximum value in range (set value × 0.001 V) |
| m + 36 | m + 50 | m + 64 | m + 78 | -10000 to 10000 | D8F0 to 2710 hex | 0 (0 hex) | | Minimum value in range (set value × 0.001 V) |
| | | | | | | | Square root function | |
| m + 37 | m + 51 | m + 65 | m + 79 | 0, 1 | 0000 to 0001 hex | 0 (0000 hex) | Square root extraction (when maximum scaling value > minimum scaling value) 0: Disable; 1: Enable | |
| | | | | | | | Process value scaling | |
| m + 38 | m + 52 | m + 66 | m + 80 | -32000 to 32000 | 8300 to FFFF hex, 0000 to 7D00 hex | 4000 (0FA0 hex) | Value stored for maximum value in range (span) | |
| m + 39 | m + 53 | m + 67 | m + 81 | -32000 to 32000 | 8300 to FFFF hex, 0000 to 7D00 hex | 0 (0000 hex) | Value stored for minimum value in range (zero) | |
| | | | | | | | Alarm supplementary functions | |
| m + 40 | m + 54 | m + 68 | m + 82 | 0 to 32000 | 0000 to 7D00 hex | 40 (0028 hex) | Alarm hysteresis (Set at process value scaling value. Shared with process value alarm and rate-of-change alarm.) | |
| m + 41 | m + 55 | m + 69 | m + 83 | 0 to 60 | 0000 to 003C hex | 0 (0000 hex) | Alarm ON-delay time (Unit: s) (Shared with process value alarm and rate-of-change alarm.) | |
| | | | | | | | Rate-of-change function | |
| m + 42 | m + 56 | m + 70 | m + 84 | -32000 to 32000 | 8300 to FFFF hex, 0000 to 7D00 hex | 4000 (0FA0 hex) | Rate-of-change range setting | Maximum rate-of-change value (Process value industrial unit; comparison time interval) |
| m + 43 | m + 57 | m + 71 | m + 85 | -32000 to 32000 | 8300 to FFFF hex, 0000 to 7D00 hex | -4000 (F060 hex) | | Minimum rate-of-change value (Process value industrial unit; comparison time interval) |
| m + 44 | m + 58 | m + 72 | m + 86 | 1 to 16 | 0001 to 0010 hex | 1 (0001 hex) | Rate-of-change comparison time interval (Unit: s) | |
| m + 45 | m + 59 | m + 73 | m + 87 | -32000 to 32000 | 8300 to FFFF hex, 0000 to 7D00 hex | 4000 (0FA0 hex) | Rate-of-change value scaling | Value stored for maximum value in range |
| m + 46 | m + 60 | m + 74 | m + 88 | -32000 to 32000 | 8300 to FFFF hex, 0000 to 7D00 hex | 0 (0000 hex) | | Value stored for minimum value in range |
| | | | | | | | Mean value processing function | |
| m + 47 | m + 61 | m + 75 | m + 89 | 1 to 16 | 0001 to 0010 hex | 4 (0004 hex) | Number of process values for calculating moving average for mean value processing | |
| Storage parameter | | | | | | | | |
| m + 90 | m + 91 | m + 92 | m + 93 | 0 to 89 | 0000 to 0059 hex | 0 (0000 hex) | Address of Data Range Error (See note.) | |

Note The ERC indicator on the Unit's front panel will light if an out-of-range setting is made in either Setting Group 1 or 2. The offset from word m to the first word containing the out-of-range error will be stored as the Address of Data Range Error in the DM Area in four digits hexadecimal. For more information, refer to *1-6 Error Processing*.

CIO Area Allocations

n = 2000 + unit number × 10 (unit number: 0 to 95)

| Direction | Word | Bit | Name | | Data range | Contents |
|---------------------------------------|------|-----|-------------|--|------------|------------------------------|
| Direct Current Input Unit to CPU Unit | n | 00 | Input No. 1 | Process value LL (low low limit) alarm | 0, 1 | 0: Process value > Set value |
| | | 01 | | Process value L (low limit) alarm | 0, 1 | 1: Process value ≤ Set value |
| | | 02 | | Process value H (high limit) alarm | 0, 1 | 0: Process value < Set value |
| | | 03 | | Process value HH (high high limit) alarm | 0, 1 | 1: Process value ≥ Set value |
| | | 04 | Input No. 2 | Process value LL (low low limit) alarm | 0, 1 | Same as for input No. 1. |
| | | 05 | | Process value L (low limit) alarm | 0, 1 | |
| | | 06 | | Process value H (high limit) alarm | 0, 1 | |
| | | 07 | | Process value HH (high high limit) alarm | 0, 1 | |
| | | 08 | Input No. 3 | Process value LL (low low limit) alarm | 0, 1 | Same as for input No. 1. |
| | | 09 | | Process value L (low limit) alarm | 0, 1 | |
| | | 10 | | Process value H (high limit) alarm | 0, 1 | |
| | | 11 | | Process value HH (high high limit) alarm | 0, 1 | |
| | | 12 | Input No. 4 | Process value LL (low low limit) alarm | 0, 1 | Same as for input No. 1. |
| | | 13 | | Process value L (low limit) alarm | 0, 1 | |
| | | 14 | | Process value H (high limit) alarm | 0, 1 | |
| | | 15 | | Process value HH (high high limit) alarm | 0, 1 | |

| Direction | Word | Bit | Name | | Data range | Contents | |
|---|-------|-------------------------|----------------------------------|---|---|--|--|
| Direct Current Input Unit to CPU Unit | n + 1 | 00 to 15 | Input No. 1 process value | | -32768 to 32767 (8000 to FFFF hex, 0000 to 7FFF hex) | The present process value is stored according to the scaling set in the allocated words of the DM Area. | |
| | n + 2 | 00 to 15 | Input No. 2 process value | | -32768 to 32767 (8000 to FFFF hex, 0000 to 7FFF hex) | | |
| | n + 3 | 00 to 15 | Input No. 3 process value | | -32768 to 32767 (8000 to FFFF hex, 0000 to 7FFF hex) | | |
| | n + 4 | 00 to 15 | Input No. 4 process value | | -32768 to 32767 (8000 to FFFF hex, 0000 to 7FFF hex) | | |
| | n + 5 | 00 to 15 | Input No. 1 rate-of-change value | | -32768 to 32767 (8000 to FFFF hex, 0000 to 7FFF hex) | The process value rate of change is stored according to the scaling set in the allocated words of the DM Area. | |
| | n + 6 | 00 to 15 | Input No. 2 rate-of-change value | | -32768 to 32767 (8000 to FFFF hex, 0000 to 7FFF hex) | | |
| | n + 7 | 00 to 15 | Input No. 3 rate-of-change value | | -32768 to 32767 (8000 to FFFF hex, 0000 to 7FFF hex) | | |
| | n + 8 | 00 to 15 | Input No. 4 rate-of-change value | | -32768 to 32767 (8000 to FFFF hex, 0000 to 7FFF hex) | | |
| | n + 9 | 00 | | Input No. 1 | Rate-of-change value L (low limit) alarm | 0, 1 | 0: Rate-of-change value > Set value 1: Rate-of-change value ≤ Set value |
| | | | | | Rate-of-change value H (high limit) alarm | 0, 1 | 0: Rate-of-change value < Set value 1: Rate-of-change value ≥ Set value |
| | | 02 | | Input No. 2 | Rate-of-change value L (low limit) alarm | 0, 1 | Same as for input No. 1. |
| Rate-of-change value H (high limit) alarm | | | | | 0, 1 | | |
| 04 | | | Input No. 3 | Rate-of-change value L (low limit) alarm | 0, 1 | Same as for input No. 1. | |
| | | | | Rate-of-change value H (high limit) alarm | 0, 1 | | |
| 06 | | | Input No. 4 | Rate-of-change value L (low limit) alarm | 0, 1 | Same as for input No. 1. | |
| | | | | Rate-of-change value H (high limit) alarm | 0, 1 | | |
| 08 | | | Input No. 1 input error | | 0, 1 | 0: Normal 1: Error (less than -17.2% or greater than 112.5%) Note Checks are conducted for inputs of 4 to 20 mA and 1 to 5 V. | |
| 09 | | | Input No. 2 input error | | 0, 1 | Same as for input No. 1. | |
| 10 | | Input No. 3 input error | | 0, 1 | Same as for input No. 1. | | |
| 11 | | Input No. 4 input error | | 0, 1 | Same as for input No. 1. | | |

Terminal Connection Diagram

Voltage input

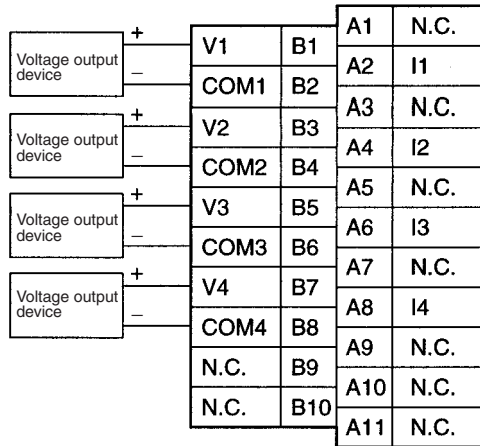

Current input

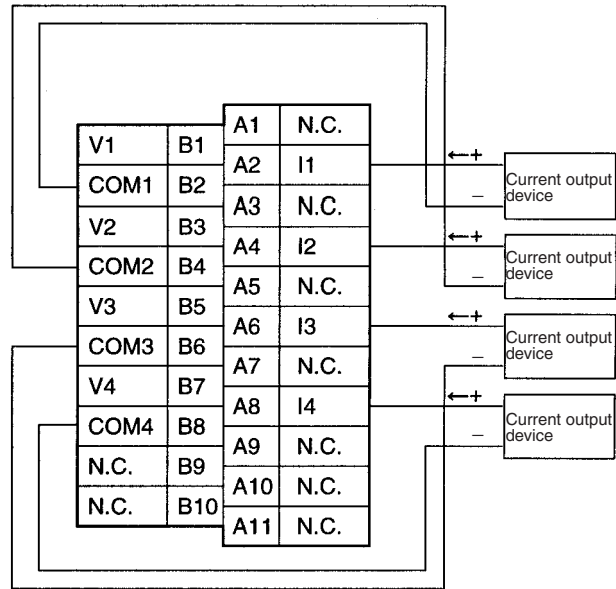

Note In both of the above cases, leave all unused inputs open between the positive and negative terminals (e.g., between B1 and B2 for voltage input No. 1).

Terminal Block Diagram

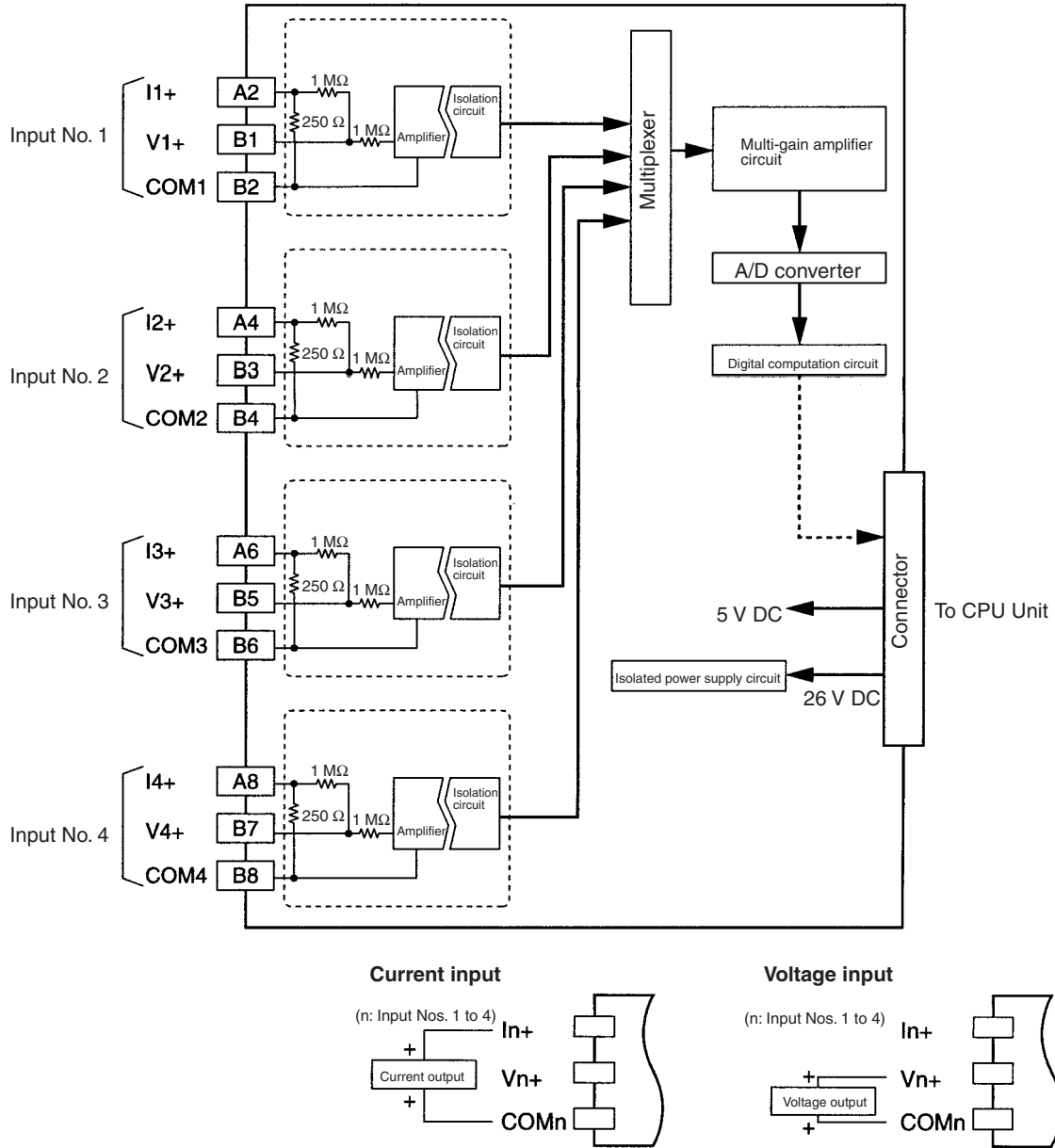

Error Processing

Conversion Data Does Not Change.

| Probable cause | Remedy |
|--|---|
| The gain for span adjustment is set to 0. | Set the gain for span adjustment to a value other than 0. |
| The minimum and maximum values for process value scaling are either the same or are set extremely low. | Set the minimum and maximum values correctly. |
| The input signal type or process value range is set incorrectly. | Check and reset the input signal type and the process value range settings. |
| An input device is malfunctioning, input wiring is faulty, or wiring is disconnected. | Check whether the input voltage has changed. Check for faulty or disconnected wiring. Check whether an input error has been detected in the I/O Area. |

Values are Not Converted as Intended.

| Probable cause | Remedy |
|--|---|
| The input signal type or process value scaling is set incorrectly. | Check and reset the input signal type and the process value scaling settings. |
| The zero/span adjustment data is incorrect. | Check and correct the zero/span adjustment settings. |
| The square root function is operating. | Set the square function so that it does not operate. |

Converted Values are Unstable.

| Probable cause | Remedy |
|--|---|
| Input signals are being affected by external noise. | Change the connection paths of the input signal lines. (Separate them from sources of noise or use shielded cable.) |
| | Insert 0.01- μ F to 0.1- μ F ceramic capacitors between the I+ and COM, and between the V+ and COM input terminals. |
| | Increase the number of values for calculating the moving average in mean value processing. |
| The scaling value is greater than the Unit's resolution. | Reduce the scaling value. |

2-12 CS1W-PDC11 Isolated-type Direct Current Input Unit

Overview

The CS1W-PDC11 Isolated-type Direct Current Input Unit provides four direct-current inputs, and sends the data to the CPU Unit each cycle. All inputs are isolated.

CS1W-PDC11

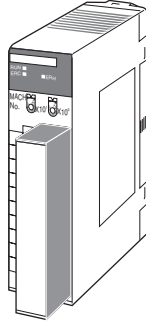

System Configuration

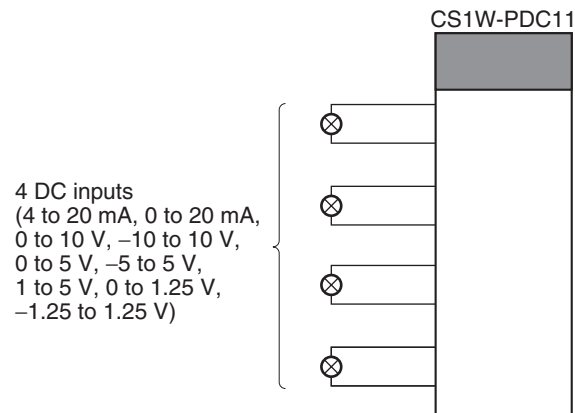

Features

- Up to four DC inputs can be made to each Unit.
 4 to 20 mA, 0 to 20 mA, 0 to 10 V, -10 to 10 V, 0 to 5 V, -5 to 5 V, 1 to 5 V, 0 to 1.25 V, or -1.25 to 1.25 V can be selected separately for each input.
- Resolution of 1/64,000 for all input range specifications.
- High-speed conversion, at 20 ms/4 inputs and 10 ms/2 inputs.
- Scaling values are transmitted to the CPU Unit in four digits hexadecimal.
- There is isolation between channels, so unwanted signal paths between input signals can be prevented.
- Square root function.
- Four values for each process value alarm input.
- ON-delay timer for process value alarm.
- Mean value processing.
- Rate-of-change calculation.
- Two values for each rate-of-change alarm input.
- Input error detection.
- Zero/span adjustment capability during operation.
- Adjustment period control.
- Peak and bottom detection.
- Top and valley detection.

- Integral value calculation.

Model Information

| Unit classification | Model number | Inputs | Input types |
|----------------------------|--------------|--------|---|
| CS-series Special I/O Unit | CS1W-PDC11 | 4 | 4 to 20 mA, 0 to 20 mA, 0 to 10 V, -10 to 10 V, 0 to 5 V, -5 to 5 V, 1 to 5 V, 0 to 1.25 V, and -1.25 to 1.25 V (separate for each input) |

Block Diagram

CPU Unit

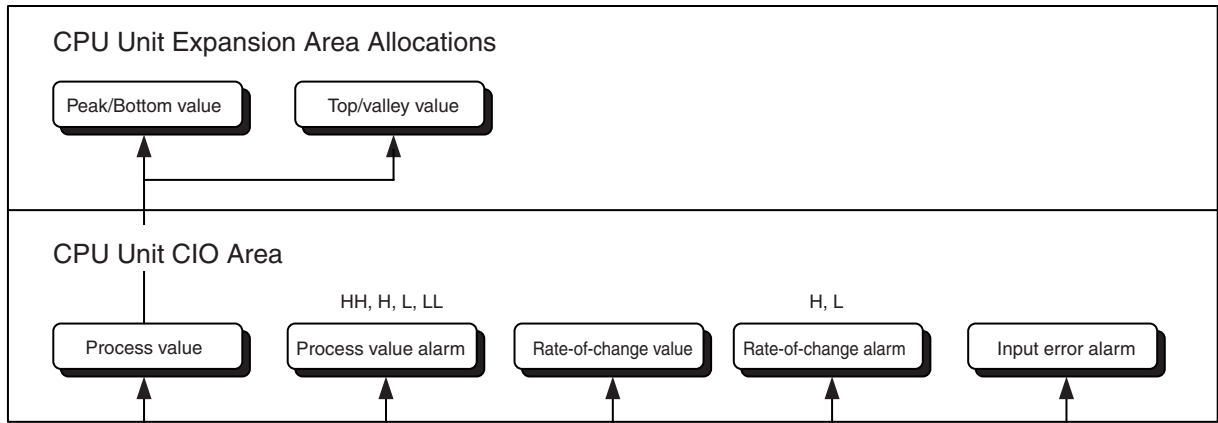

Isolated-type Direct Current Input Unit

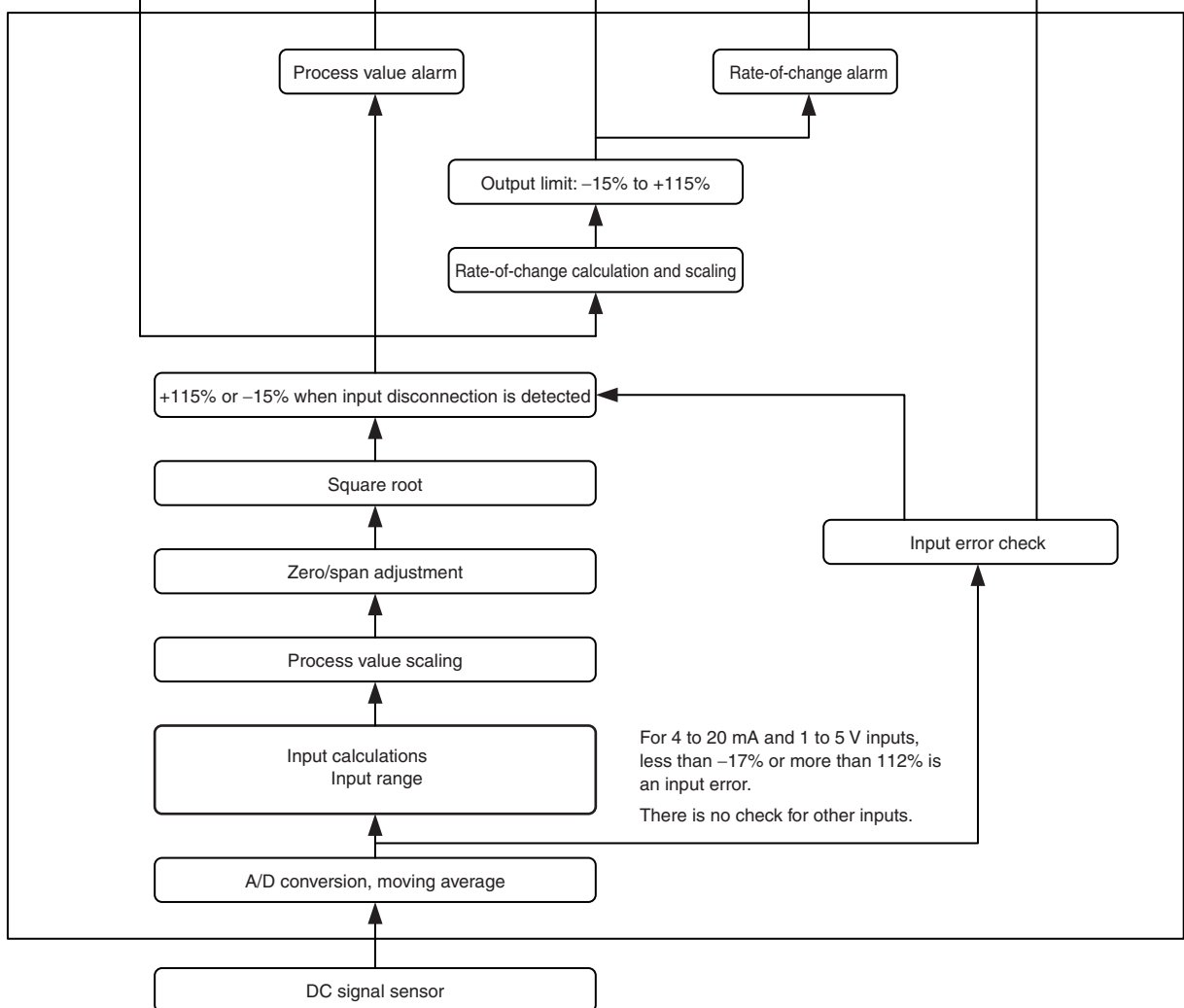

Specifications

| Item | | Specifications |
|---------------------------------------|--|--|
| Model | | CS1W-PDC11 |
| Applicable PLC | | CS Series |
| Unit classification | | CS-series Special I/O Unit |
| Mounting position | | CS-series CPU Rack or CS-series Expansion Rack (Cannot be mounted to C200H Expansion I/O Rack or SYSMAC BUS Remote I/O Slave Rack.) |
| Maximum number of Units | | 80 (within the allowable current consumption and power consumption range) |
| Unit numbers | | 00 to 95 (Cannot duplicate Special I/O Unit numbers.) |
| Areas for data exchange with CPU Unit | Special I/O Unit Area | 10 words/Unit Isolated-type Direct Current Input Unit to CPU Unit: All process values, process value alarms (LL, L, H, HH), rate-of-change values, rate-of-change alarms (L, H), disconnection alarms, cold junction sensor errors, adjustment period end/notice |
| | DM Area words allocated to Special I/O Units | 100 words/Unit CPU Unit to Isolated-type Direct Current Input Unit: Input signal type, scaling of process value in industrial units, process value alarm setting (L, H), inrush input upper limit, inrush input upper limit time, zero/span adjustment value, Square root function. Temperature input signal type, input range (user set), scaling of process value data to be stored in allocated words in CIO area, rate-of-change input range, scaling of rate-of-change data, number of items for moving average, process value alarm setting (LL, L, H, HH), rate-of-change alarm setting (L, H), zero/span adjustment value |
| | Expansion Control/Monitor Area | 35 words/Unit CPU Unit to Isolated-type Direct Current Input Unit: Bits for beginning or resetting the hold function selection, adjustment period control, control bits Isolated-type Direct Current Input Unit to CPU Unit: Adjustment period notices, peak and bottom values, top and valley values, integral values |
| | Expansion Setting Area | 46 words/Unit CPU Unit to Isolated-type Direct Current Input Unit: Expansion Setting Area settings, adjustment period control, peak and bottom detection, top and valley detection, integral value calculation |
| Number of inputs | | 4 |
| Input signal type | | 4 to 20 mA, 0 to 20 mA, 0 to 10 V, -10 to 10 V, 0 to 5 V, -5 to 5 V, 1 to 5 V, 0 to 1.25 V, -1.25 to 1.25 V (separate for each input), and ± 10 -V user-set range (specified range within -10.000 V to 10.000 V) |
| Scaling | | Data to be stored in the allocated words in the CIO area must be scaled (Any minimum and maximum values can be set.) (4 inputs set separately.) Data can be converted at 0% to 100%. |
| Data storage in the CIO Area | | The value derived from carrying out the following processing in order of the actual process data in the input range is stored in four digits hexadecimal (binary values) in the allocated words in the CIO Area. 1) Mean value processing → 2) Scaling → 3) Zero/span adjustment → 4) Square root calculation → 5) Output limits |
| Accuracy (25°C) | | $\pm 0.05\%$ |
| Temperature coefficient | | $\pm 0.008\%/^{\circ}\text{C}$ |
| Resolution | | 1/64,000 |
| Input signal range | | For 4 to 20 mA, 0 to 20 mA, 0 to 10 V, 0 to 5 V, 1 to 5 V, 0 to 1.25 V inputs: -15 to 115% For -10 to 10 V, -5 to 5 V, -1.25 to 1.25 V inputs: -7.5 to 107.5% |

| Item | | Specifications |
|--|--|---|
| Input impedance | | For current inputs: 250 Ω (typical) For voltage inputs: 1 MΩ min. |
| Warmup time | | 10 min |
| Response time | | 100 ms (travel time from input 0% to 90%, for ±10 V step input and with moving average for 4 samples) |
| Conversion period | | 20 ms/4 inputs, 10 ms/2 inputs, selectable in words allocated to the Unit as a Special I/O Unit. |
| Maximum time to store data in CPU Unit | | Conversion period + one CPU Unit cycle |
| Input error detection | | Check only for 4 to 20 mA and 1 to 5 V. Error detected for -17.2% (1.25 mA, 0.3125 V) or less and 112.5% (22 mA, 5.5 V) or more. |
| Operation at input disconnection | | For 4 to 20 mA and 1 to 5 V: Stores -15% process value. For all other ranges: Stores same process value as 0-V or 0-mA inputs. |
| Input disconnection detection delay time | | Approx. 1 s. |
| Function | Mean value processing (input filter) | Calculates the moving average for the past specified number of process values (1 to 128 can be specified), and stores that value in the CIO Area as the process value. |
| | Process value alarm | Process value 4-point alarm (LL, L H, HH), hysteresis, and ON-delay timer (0 to 60 s) are available. |
| | Rate-of-change calculation | Calculates the amount of change per comparison time interval (1 to 16 s). |
| | Rate-of-change alarm | Rate-of-change 2-point alarm (H, L), alarm hysteresis, and ON-delay timer (0 to 60 s are available, shared with process value alarm). |
| | Square root calculation | When the maximum value for process value scaling is A and the minimum value is B, $\text{Output} = \sqrt{(A - B) \times (\text{input} - B) + B}$ Drop-out: Output approx. 7% max. linear (output = input) characteristic Note 1 The square root function can only be used when the maximum scaling value is greater than the minimum scaling value. The square root will not be found if the maximum is smaller than the minimum. Note 2 When the square root function is used, set the scaling values after square root calculation (e.g., for flow rates or other values) for the process value scaling A and B settings. |
| | Adjustment period control | When zero/span adjustment is executed, the date is internally recorded at the Unit. When the preset zero/span adjustment period and the notice of days remaining set in the Expansion Setting Area have elapsed, this function turns ON a warning flag to give notice that it is time for readjustment. |
| | Peak and bottom detection | Detects the maximum (peak) and minimum (bottom) analog input values, from when the Hold Start Bit (output) allocated to the Expansion Control/Monitor Area turns ON until it turns OFF. These values are stored as the peak and bottom values in the Expansion Control/Monitor Area. |
| | Top and valley detection | This function detects the top and valley values for analog inputs, from when the Hold Start Bit (output) allocated to the Expansion Control/Monitor Area turns ON until it turns OFF. These values are stored as the top and valley values in the Expansion Control/Monitor Area. |
| Integral value calculation | This function calculates the analog input value's time integral. The integral value is calculated and output to the Expansion Control/Monitor Area when the Integral Value Calculation Start Bit in the Expansion Control/Monitor Area is turned ON. | |
| Isolation | | Between inputs and between inputs and PLC signals: Isolation by transformer and photocoupler. |
| Insulation resistance | | 20 MΩ (at 500 V DC) between all inputs |
| Dielectric strength | | Between inputs: 1,000 V AC, at 50/60 Hz, for 1 min, leakage current 10 mA max. |
| External connections | | Terminal block (detachable) |
| Unit number settings | | Set by rotary switches on front panel, from 0 to 95. |

| Item | Specifications |
|-------------------------------|--|
| Indicators | Three LED indicators on front panel (for normal operation, errors detected at the Direct Current Input Unit, and errors detected at the CPU Unit). |
| Front panel connector | Sensor input connector terminal block (detachable) |
| Effect on CPU Unit cycle time | 0.3 ms |
| Current consumption | 5 V DC at 120 mA max., 26 V DC at 120 mA max. |
| Dimensions | 35 × 130 × 126 mm (W × H × D) Note The height including the Backplane is 145 mm. |
| Weight | 450 g max. |
| Standard accessories | Short bars (for current input) |

Accuracy and Resolution in ±10-V User-set Range

The ±10-V user-set range allows the input signal's input range to be set to any range within -10.000 V to 10.000 V. Accuracy and resolution, however, are not determined by the input range, but rather by the measurable input range (-10.000 V to 10.000 V). Therefore, accuracy and resolution do not change even if a narrow input range is set.

DM Area Allocations

First word: word m. m = D20000 + unit number × 100 (unit number: 0 to 95)

| DM Area address | | | | Data range | | Default | Data contents |
|---|-------------|-------------|-------------|-----------------|------------------------------------|-----------------|--|
| Input No. 1 | Input No. 2 | Input No. 3 | Input No. 4 | Decimal | Hexadecimal | | |
| m | | | | 12345, 0 | 3039, 0000 hex | 0000 hex | Default block read command Specifies the direction of data transfer when the PLC is turned ON or the Unit is restarted for DM Area words m+1 to m+93. <ul style="list-style-type: none"> 12345 (3039 hex): The data in words m+1 to m+93 is transferred from the Direct Current Input Unit to the CPU Unit. When the transfer is completed, the value will become 0000 hex. Other than 12345 (such as 0000 hex): The data in the allocated words of DM Area is transferred from the CPU Unit to the Direct Current Input Unit. |
| | | | | | | | Number of inputs setting |
| m+1 | | | | 0, 1 | 0000, 0001 hex | 0 | 0: 4 inputs; 1: 2 inputs |
| Setting Group 1 (continuously refreshed area): Parameters that are continuously refreshed during PLC operation (regardless of the CPU Unit's operation mode) | | | | | | | |
| | | | | | | | Process value alarm settings |
| m+2 | m+10 | m+18 | m+26 | -32768 to 32767 | 8000 to FFFF hex, 0000 to 7FFF hex | 4200 (1068 hex) | Process value HH (high high limit) alarm setting (Set at process value scaling value.) |
| m+3 | m+11 | m+19 | m+27 | -32768 to 32767 | 8000 to FFFF hex, 0000 to 7FFF hex | 4000 (0FA0 hex) | Process value H (high limit) alarm setting (Set at process value scaling value.) |
| m+4 | m+12 | m+20 | m+28 | -32768 to 32767 | 8000 to FFFF hex, 0000 to 7FFF hex | 0 (0000 hex) | Process value L (low limit) alarm setting (Set at process value scaling value.) |
| m+5 | m+13 | m+21 | m+29 | -32768 to 32767 | 8000 to FFFF hex, 0000 to 7FFF hex | -200 (FF38 hex) | Process value LL (low low limit) alarm setting (Set at process value scaling value.) |
| | | | | | | | Rate-of-change value alarm settings |
| m+6 | m+14 | m+22 | m+30 | -32768 to 32767 | 8000 to FFFF hex, 0000 to 7FFF hex | 4000 (0FA0 hex) | Rate-of-change value H (high limit) alarm setting (Set at rate-of-change scaling value.) |
| m+7 | m+15 | m+23 | m+31 | -32768 to 32767 | 8000 to FFFF hex, 0000 to 7FFF hex | 0 (0000 hex) | Rate-of-change value L (low limit) alarm setting (Set at rate-of-change scaling value.) |

| DM Area address | | | | Data range | | Default | Data contents | |
|--|-------------|-------------|-------------|---------------------|------------------------------------|------------------|--|--|
| Input No. 1 | Input No. 2 | Input No. 3 | Input No. 4 | Decimal | Hexadecimal | | | |
| | | | | | | | | Zero/span adjustment |
| m+8 | m+16 | m+24 | m+32 | 0 to 32000 | 0000 to 7D00 hex | 10000 (2710 hex) | Gain for span adjustment (set value × 0.0001%) | |
| m+9 | m+17 | m+25 | m+33 | -32000 to 32000 | 8300 to FFFF hex, 0000 to 7D00 hex | 0 (0000 hex) | Zero adjustment value (Set at process value scaling value.) | |
| Setting Group 2 (initial settings area): Parameters that are transferred one time from the CPU Unit to the Direct Current Input Unit if word m contains other than 12345 when the PLC is turned ON or the Direct Current Input Unit is restarted. | | | | | | | | |
| | | | | | | | | Input signal type |
| m+34 | m+48 | m+62 | m+76 | 0 to 9 | 0000 to 0009 hex | 1 (0001 hex) | 0: ±10 V; 1: 0 to 10 V; 2: ±5 V; 3: 0 to 5 V; 4: 1 to 5 V; 5: 4 to 20 mA; 6: ±10 V user-set range; 7: 0 to 20 mA; 8: ±1.25 V; 9: 0 to 1.25 V | |
| | | | | | | | | Process value input range |
| m+35 | m+49 | m+63 | m+77 | -1000 to 1000 | D8F0 to FFFF hex, 0000 to 2710 hex | 10000 (2710 hex) | ±10-V user-set range | Maximum value in range (set value × 0.001 V) |
| m+36 | m+50 | m+64 | m+78 | -1000 to 1000 | D8F0 to FFFF hex, 0000 to 2710 hex | 0 (0000 hex) | | Minimum value in range (set value × 0.001 V) |
| | | | | | | | | Square root function |
| m+37 | m+51 | m+65 | m+79 | 0, 1 | 0000, 0001 hex | 0 (0000 hex) | Square root extraction (when maximum scaling value > minimum scaling value) 0: Disable; 1: Enable | |
| | | | | | | | | Process value scaling |
| m+38 | m+52 | m+66 | m+80 | -32000 to 32000 | 8300 to FFFF hex, 0000 to 7D00 hex | 4000 (0FA0 hex) | Value stored for maximum value in range (span) | |
| m+39 | m+53 | m+67 | m+81 | -32000 to 32000 | 8300 to FFFF hex, 0000 to 7D00 hex | 0 (0000 hex) | Value stored for minimum value in range (zero) | |
| | | | | | | | | Alarm supplementary functions |
| m+40 | m+54 | m+68 | m+82 | 0 to 32000 | 0000 to 7D00 hex | 40 (0028 hex) | Alarm hysteresis (Set at process value scaling value. Shared with process value alarm and rate-of-change alarm.) | |
| m+41 | m+55 | m+69 | m+83 | 0 to 60 | 0000 to 003C hex | 0 (0000 hex) | Alarm ON-delay time (Unit: s) (Shared with process value alarm and rate-of-change alarm.) | |
| | | | | | | | | Rate-of-change function |
| m+42 | m+56 | m+70 | m+84 | -32000 to 32000 | 8300 to FFFF hex, 0000 to 7D00 hex | 4000 (0FA0 hex) | Rate-of-change range setting | Maximum rate-of-change value (Process value industrial unit; comparison time interval) |
| m+43 | m+57 | m+71 | m+85 | -32000 to 32000 | 8300 to FFFF hex, 0000 to 7D00 hex | -4000 (F060 hex) | | Minimum rate-of-change value (Process value industrial unit; comparison time interval) |
| m+44 | m+58 | m+72 | m+86 | 1 to 16 | 0001 to 0010 hex | 1 (0001 hex) | Rate-of-change comparison time interval (Unit: s) | |
| m+45 | m+59 | m+73 | m+87 | -32000 to 32000 | 8300 to FFFF hex, 0000 to 7D00 hex | 4000 (0FA0 hex) | Rate-of-change value scaling | Value stored for maximum value in range |
| m+46 | m+60 | m+74 | m+88 | -32000 to 32000 | 8300 to FFFF hex, 0000 to 7D00 hex | -4000 (F060 hex) | | Value stored for minimum value in range |
| | | | | | | | | Mean value processing function |
| m+47 | m+61 | m+75 | m+89 | 1 to 128 | 0001 to 0080 hex | 25 (0019 hex) | Number of process values for calculating moving average for mean value processing | |
| Display parameter | | | | | | | | |
| m+90 | m+91 | m+92 | m+93 | 0 to 99, 100 to 1XX | 0000 to 0063 hex, 0064 to 0XXX hex | 0 (0000 hex) | Address of Data Range Error (See note.) | |

| DM Area address | | | | Data range | | Default | Data contents |
|---|-------------|-------------|-------------|------------|------------------|---------|---|
| Input No. 1 | Input No. 2 | Input No. 3 | Input No. 4 | Decimal | Hexadecimal | | |
| Expansion Setting Area Allocation Settings | | | | | | | |
| m+98 | | | | 0 to 5 | 0000 to 0005 hex | --- | Area of Expansion Setting Area 0: Not used; 1: DM; 2: CIO; 3: W; 4: H; 5: EM |
| m+99 | | | | 0 to 32767 | 0000 to 7FFF hex | --- | First Word in Expansion Setting Area |

- Note**
- The ERC indicator on the Unit's front panel will light if an out-of-range setting is made in either Setting Group 1 (continually refreshed area) or 2 (initial settings area), or in the Expansion Setting Area. The offset from word m to the first address containing the out-of-range error will be stored as the Address of Data Range Error in the DM Area in four digits hexadecimal.
If the first memory address where the out-of-range error occurred is in the Expansion Setting Area, the Address of Data Range Area will be +100 or later. If the first word of the Expansion Setting Area has the error, the Address of Data Range Area will be +100.
 - When specifying an expansion setting area be sure that it does not overlap with other areas that are being used. If areas overlap, the words that are allocated may be overwritten, resulting in unexpected operation.
 - When specifying the first word in an expansion setting area be sure that the end of the memory area is not exceeded.

Expansion Setting Area Allocations

First word: word o. o = address specified in word m+99 in the area specified by word m+98 in the DM Area.

| DM Area address | | | | Data range | | Default | Data contents |
|--|-------------|-------------|-------------|-----------------|------------------------------------|------------------|--|
| Input No. 1 | Input No. 2 | Input No. 3 | Input No. 4 | Decimal | Hexadecimal | | |
| Setting Group 3 (initial settings area): Parameters that are transferred one time from the CPU Unit to the Direct Current Input Unit if word m contains other than 12345 when the PLC is turned ON or the Direct Current Input Unit is restarted. | | | | | | | |
| | | | | | | | Expansion Control/Monitor Area Settings |
| o | | | | 0 to 5 | 0000 to 0005 hex | --- | Expansion Control/Monitor Area allocation 0: Not used. 1: DM; 2: CIO; 3: W; 4: H; 5: EM |
| o+1 | | | | 0 to 32767 | 0000 to 7FFF hex | --- | Expansion Control/Monitor Area first word |
| | | | | | | | Zero/span adjustment supplementary function |
| o+2 | o+13 | o+24 | o+35 | 0 to 32000 | 0000 to 7D00 hex | 10000 (2710 hex) | Span adjustment position (Input span percentage) |
| o+3 | o+14 | o+25 | o+36 | -32000 to 32000 | 8300 to FFFF hex, 0000 to 7D00 hex | 0 (0000 hex) | Zero adjustment position (Input span percentage) |
| o+4 | o+15 | o+26 | o+37 | 0 to 9999 | 0000 to 270F hex | 365 (016D hex) | Zero/span adjustment period (Unit: Days) |
| o+5 | o+16 | o+27 | o+38 | 0 to 9999 | 0000 to 270F hex | 30 (001E hex) | Notice of days remaining (Unit: Days) |
| | | | | | | | Not used |
| o+6 | o+17 | o+28 | o+39 | --- | --- | 0 (0000 hex) | Not used |
| o+7 | o+18 | o+29 | o+40 | | | | |
| o+8 | o+19 | o+30 | o+41 | | | | |
| | | | | | | | Top and valley hold |
| o+9 | o+20 | o+31 | o+42 | 0 to 32000 | 0000 to 7D00 hex | 40 (0028 hex) | Hysteresis |
| | | | | | | | Integral value calculation |

| DM Area address | | | | Data range | | Default | Data contents |
|-----------------|-------------|-------------|-------------|------------|----------------|--------------|--------------------------------------|
| Input No. 1 | Input No. 2 | Input No. 3 | Input No. 4 | Decimal | Hexadecimal | | |
| o+10 | o+21 | o+32 | o+43 | 0, 1 | 0000, 0001 hex | 0 (0000 hex) | Integer unit 0: Minutes; 1: Hours |
| | | | | | | | Not used |
| o+11 | o+22 | o+33 | o+44 | --- | --- | 0 (0000 hex) | Not used. |
| o+12 | o+23 | o+34 | o+45 | | | | |

- Note**
1. When specifying an expansion control/monitor area be sure that it does not overlap with other areas that are being used. If areas overlap, the words that are allocated may be overwritten, resulting in unexpected operation.
 2. When specifying the first word in an expansion control/monitor area be sure that the end of the memory area is not exceeded.

CIO Area Allocations

First word: word n. $n = 2000 + \text{unit number} \times 10$ (unit number: 0 to 95)

| Direction | Word | Bit | Name | Data range | Contents | |
|---------------------------------------|------|-----|-------------|--|----------|--|
| Direct Current Input Unit to CPU Unit | n | 00 | Input No. 1 | Process value LL (low low limit) alarm | 0, 1 | 0: Process value > Set value 1: Process value ≤ Set value |
| | | 01 | | Process value L (low limit) alarm | 0, 1 | |
| | | 02 | | Process value H (high limit) alarm | 0, 1 | |
| | | 03 | | Process value HH (high high limit) alarm | 0, 1 | |
| | | 04 | Input No. 2 | Process value LL (low low limit) alarm | 0, 1 | Same as for input No. 1. |
| | | 05 | | Process value L (low limit) alarm | 0, 1 | |
| | | 06 | | Process value H (high limit) alarm | 0, 1 | |
| | | 07 | | Process value HH (high high limit) alarm | 0, 1 | |
| | | 08 | Input No. 3 | Process value LL (low low limit) alarm | 0, 1 | |
| | | 09 | | Process value L (low limit) alarm | 0, 1 | |
| | | 10 | | Process value H (high limit) alarm | 0, 1 | |
| | | 11 | | Process value HH (high high limit) alarm | 0, 1 | |
| | | 12 | Input No. 4 | Process value LL (low low limit) alarm | 0, 1 | |
| | | 13 | | Process value L (low limit) alarm | 0, 1 | |
| | | 14 | | Process value H (high limit) alarm | 0, 1 | |
| | | 15 | | Process value HH (high high limit) alarm | 0, 1 | |

| Direction | Word | Bit | Name | Data range | Contents |
|--|------|---------|----------------------------------|---|--|
| Direct Current Input Unit to CPU Unit, continued | n+1 | 0 to 15 | Input No. 1 process value | -32768 to 32767 (8000 to FFFF hex, 0000 to 7FFF hex) | The present process value is stored according to the scaling set in the allocated words of the DM Area. |
| | n+2 | 0 to 15 | Input No. 2 process value | -32768 to 32767 (8000 to FFFF hex, 0000 to 7FFF hex) | |
| | n+3 | 0 to 15 | Input No. 3 process value | -32768 to 32767 (8000 to FFFF hex, 0000 to 7FFF hex) | |
| | n+4 | 0 to 15 | Input No. 4 process value | -32768 to 32767 (8000 to FFFF hex, 0000 to 7FFF hex) | |
| | n+5 | 0 to 15 | Input No. 1 rate-of-change value | -32768 to 32767 (8000 to FFFF hex, 0000 to 7FFF hex) | The present rate-of-change value is stored according to the scaling set in the allocated words of the DM Area. |
| | n+6 | 0 to 15 | Input No. 2 rate-of-change value | -32768 to 32767 (8000 to FFFF hex, 0000 to 7FFF hex) | |
| | n+7 | 0 to 15 | Input No. 3 rate-of-change value | -32768 to 32767 (8000 to FFFF hex, 0000 to 7FFF hex) | |
| | n+8 | 0 to 15 | Input No. 4 rate-of-change value | -32768 to 32767 (8000 to FFFF hex, 0000 to 7FFF hex) | |

| Direction | Word | Bit | Name | | Data range | Contents |
|--|-----------|-----|------------------------------------|---|--|--|
| Direct Current Input Unit to CPU Unit, continued | n+9 | 00 | Input No. 1 | Rate-of-change value L (low limit) alarm | 0, 1 | 0: Rate-of-change value > set value 1: Rate-of-change value ≤ set value |
| | | 01 | | Rate-of-change value H (high limit) alarm | 0, 1 | 0: Rate-of-change value < set value 1: Rate-of-change value ≥ set value |
| | | 02 | Input No. 2 | Rate-of-change value L (low limit) alarm | 0, 1 | Same as for input No. 1. |
| | | 03 | | Rate-of-change value H (high limit) alarm | 0, 1 | |
| | | 04 | Input No. 3 | Rate-of-change value L (low limit) alarm | 0, 1 | |
| | | 05 | | Rate-of-change value H (high limit) alarm | 0, 1 | |
| | | 06 | Input No. 4 | Rate-of-change value L (low limit) alarm | 0, 1 | |
| | | 07 | | Rate-of-change value H (high limit) alarm | 0, 1 | |
| | | 08 | Input No. 1 input error | 0, 1 | 0: Normal 1: Error (less than -17.2% or greater than 112.5%) Note Checks are conducted for inputs of 4 to 20 mA and 1 to 5 V. | |
| | | 09 | Input No. 2 input error | 0, 1 | | |
| | | 10 | Input No. 3 input error | 0, 1 | | |
| | | 11 | Input No. 4 input error | 0, 1 | | |
| | | 12 | Not used. | 0, 1 | Not used. | |
| | | 13 | Zero/span adjustment period end | 0, 1 | 0: Adjustment enabled 1: Adjustment ended | |
| | | 14 | Zero/span adjustment period notice | 0, 1 | 0: Adjustment enabled 1: Notice period | |
| 15 | Not used. | 0 | Not used. | | | |

Expansion Control/Monitor Area Allocations

First word: p. p = address specified in word o+1 in the area specified by word o in the Expansion Setting Area.

| Direction | Word | Bit | Name | Data range | Contents | |
|--|----------|----------|--|--|---|---|
| CPU Unit to Direct Current Input Unit, continued | p | 00 to 15 | Not used. | Not used. | Not used. | |
| | p+1 | 00 | Input No. 1 hold function selection | 0, 1 | 0: Peak and bottom 1: Top and valley | |
| | | 01 | Input No. 2 hold function selection | 0, 1 | | |
| | | 02 | Input No. 3 hold function selection | 0, 1 | | |
| | | 03 | Input No. 4 hold function selection | 0, 1 | | |
| | | 04 to 07 | Not used. | 0 | Not used. | |
| | | 08 | Input No. 1 hold start | 0, 1 | 0: Do not hold. 1: Hold | |
| | | 09 | Input No. 2 hold start | 0, 1 | | |
| | | 10 | Input No. 3 hold start | 0, 1 | | |
| | | 11 | Input No. 4 hold start | 0, 1 | | |
| | | 12 | Input No. 1 hold value reset | 0, 1 | 0: Normal operation 1: Reset hold value. | |
| | | 13 | Input No. 2 hold value reset | 0, 1 | | |
| | | 14 | Input No. 3 hold value reset | 0, 1 | | |
| | | 15 | Input No. 4 hold value reset | 0, 1 | | |
| | | p+2 | 00 | Input No. 1 integral value calculation start | 0, 1 | 0: Do not start calculation 1: Start calculation |
| | | | 01 | Input No. 2 integral value calculation start | 0, 1 | |
| | 02 | | Input No. 3 integral value calculation start | 0, 1 | | |
| | 03 | | Input No. 4 integral value calculation start | 0, 1 | | |
| | 04 | | Input No. 1 integral value reset | 0, 1 | 0: Normal operation 1: Integral value reset | |
| | 05 | | Input No. 2 integral value reset | 0, 1 | | |
| | 06 | | Input No. 3 integral value reset | 0, 1 | | |
| | 07 | | Input No. 4 integral value reset | 0, 1 | | |
| | 08 to 15 | | Not used. | 0 | | Not used. |
| | p+3 | 00 | Input No. 1 zero/span adjustment update bit | 0, 1 | 0: Normal operation 1: Update adjustment date (Remains ON while writing external FROM.) | |
| | | 01 | Input No. 2 zero/span adjustment update bit | 0, 1 | | |
| | | 02 | Input No. 3 zero/span adjustment update bit | 0, 1 | | |
| | | 03 | Input No. 4 zero/span adjustment update bit | 0, 1 | | |
| | | 04 to 15 | Not used. | 0 | Not used. | |

| Direction | Word | Bit | Name | | Data range | Contents |
|---------------------------------------|--------------|---------------------|---------------------|--|---|---|
| Direct Current Input Unit to CPU Unit | p+4 | 00 | Input No. 1 | Zero/span adjustment period end | 0, 1 | 0: Adjustment enabled. 1: Adjustment period end |
| | | 01 | | Zero/span adjustment period notice | 0, 1 | 0: Adjustment enabled. |
| | | 02 | Input No. 2 | Zero/span adjustment period end | 0, 1 | 1: Notice period in effect. |
| | | 03 | | Zero/span adjustment period notice | 0, 1 | Remains set to 1 if the zero/span adjustment bit has never been ON. |
| | | 04 | Input No. 3 | Zero/span adjustment period end | 0, 1 | |
| | | 05 | | Zero/span adjustment period notice | 0, 1 | |
| | | 06 | Input No. 4 | Zero/span adjustment period end | 0, 1 | |
| | | 07 | | Zero/span adjustment period notice | 0, 1 | |
| | | 08 | External FROM error | | 0, 1 | |
| | | 09 to 15 | Not used. | | 0 | Not used. |
| | p+5 | 00 to 15 | Input No. 1 | Day of final adjustment date | 0100 to 3100 (BCD) | Remains set to FFFF if the zero/span adjustment bit has never been ON. |
| | p+6 | 00 to 15 | | Year and month of final adjustment date | 0001 to 9912 (BCD) | |
| | p+7 | 00 to 15 | Input No. 2 | Day of final adjustment date | 0100 to 3100 (BCD) | |
| | p+8 | 00 to 15 | | Year and month of final adjustment date | 0001 to 9912 (BCD) | |
| | p+9 | 00 to 15 | Input No. 3 | Day of final adjustment date | 0100 to 3100 (BCD) | |
| | p+10 | 00 to 15 | | Year and month of final adjustment date | 0001 to 9912 (BCD) | |
| | p+11 | 00 to 15 | Input No. 4 | Day of final adjustment date | 0100 to 3100 (BCD) | |
| | p+12 | 00 to 15 | | Year and month of final adjustment date | 0001 to 9912 (BCD) | |
| | p+13 to p+16 | 00 to 15 | Not used. | | 0000 | Not used. |
| | p+17 | 00 to 15 | Input No. 1 | Peak/top value | -32728 to +32767 (8000 to FFFF hex, 0000 to 7FFF hex) | Counts the number of repetitions of conditional operations set in the Expansion Setting Area. |
| p+18 | 00 to 15 | Bottom/valley value | | -32728 to +32767 (8000 to FFFF hex, 0000 to 7FFF hex) | The bottom or valley value is stored according to the scaling set in the DM Area. | |

| Direction | Word | Bit | Name | | Data range | Contents |
|---------------------------------------|----------|-------------|------------------------------|---|---|---|
| Direct Current Input Unit to CPU Unit | p+19 | 00 to 15 | Input No. 2 | Peak/top value | -32728 to +32767 (8000 to FFFF hex, 0000 to 7FFF hex) | Same as for Input No. 1. |
| | p+20 | 00 to 15 | | Bottom/valley value | -32728 to +32767 (8000 to FFFF hex, 0000 to 7FFF hex) | |
| | p+21 | 00 to 15 | Input No. 3 | Peak/top value | -32728 to +32767 (8000 to FFFF hex, 0000 to 7FFF hex) | |
| | p+22 | 00 to 15 | | Bottom/valley value | -32728 to +32767 (8000 to FFFF hex, 0000 to 7FFF hex) | |
| | p+23 | 00 to 15 | Input No. 4 | Peak/top value | -32728 to +32767 (8000 to FFFF hex, 0000 to 7FFF hex) | |
| | p+24 | 00 to 15 | | Bottom/valley value | -32728 to +32767 (8000 to FFFF hex, 0000 to 7FFF hex) | |
| | p+25 | 00 to 15 | Input No. 1 | Integral value (lower digit) | -2147483648 to 2147483647 (80000000 to FFFFFFFF hex, 00000000 to 7FFFFFFF hex) | The integral value for the present value is stored according to the scaling set in the DM Area. |
| | p+26 | 00 to 15 | | Integral value (upper digit) | | |
| | p+27 | 00 to 15 | Input No. 2 | Integral value (lower digit) | -2147483648 to 2147483647 (80000000 to FFFFFFFF hex, 00000000 to 7FFFFFFF hex) | |
| | p+28 | 00 to 15 | | Integral value (upper digit) | | |
| | p+29 | 00 to 15 | Input No. 3 | Integral value (lower digit) | -2147483648 to 2147483647 (80000000 to FFFFFFFF hex, 00000000 to 7FFFFFFF hex) | |
| | p+30 | 00 to 15 | | Integral value (upper digit) | | |
| p+31 | 00 to 15 | Input No. 4 | Integral value (lower digit) | -2147483648 to 2147483647 (80000000 to FFFFFFFF hex, 00000000 to 7FFFFFFF hex) | | |
| p+32 | 00 to 15 | | Integral value (upper digit) | | | |
| p+33 and p+34 | 00 to 15 | Not used. | | 0000 | Not used. | |

Terminal Connection Diagram

Voltage Inputs

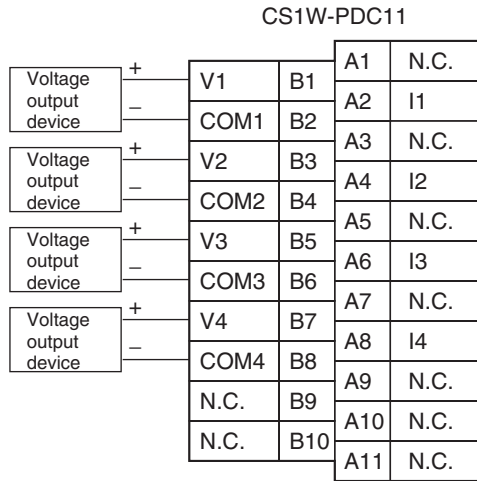

Current inputs

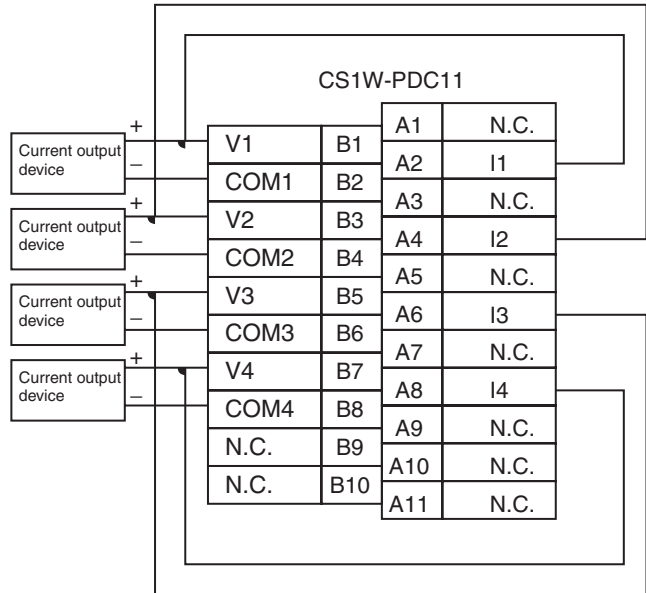

Note

- In both of the above cases, leave all unused inputs open between the positive and negative terminals (e.g., between B1 and B2 for voltage input No. 1).
- Always ground the GR terminal on the Power Supply Unit of the PLC.
- If the input device uses a voltage generator, temperature compensator, or similar device, then ground the input device if it has a ground terminal.
- Always short-circuit the V and I terminals when using current input.
- Be sure to tighten the short bars to a torque of 0.5 N·m. Loose short bars may result in conversion errors.

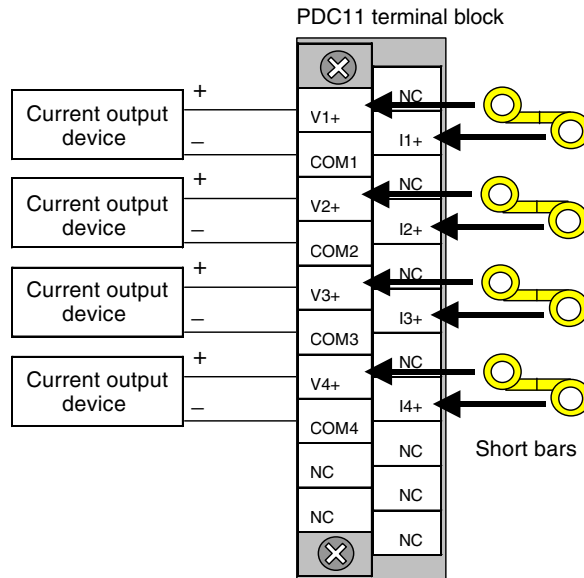

Terminal Block Diagram

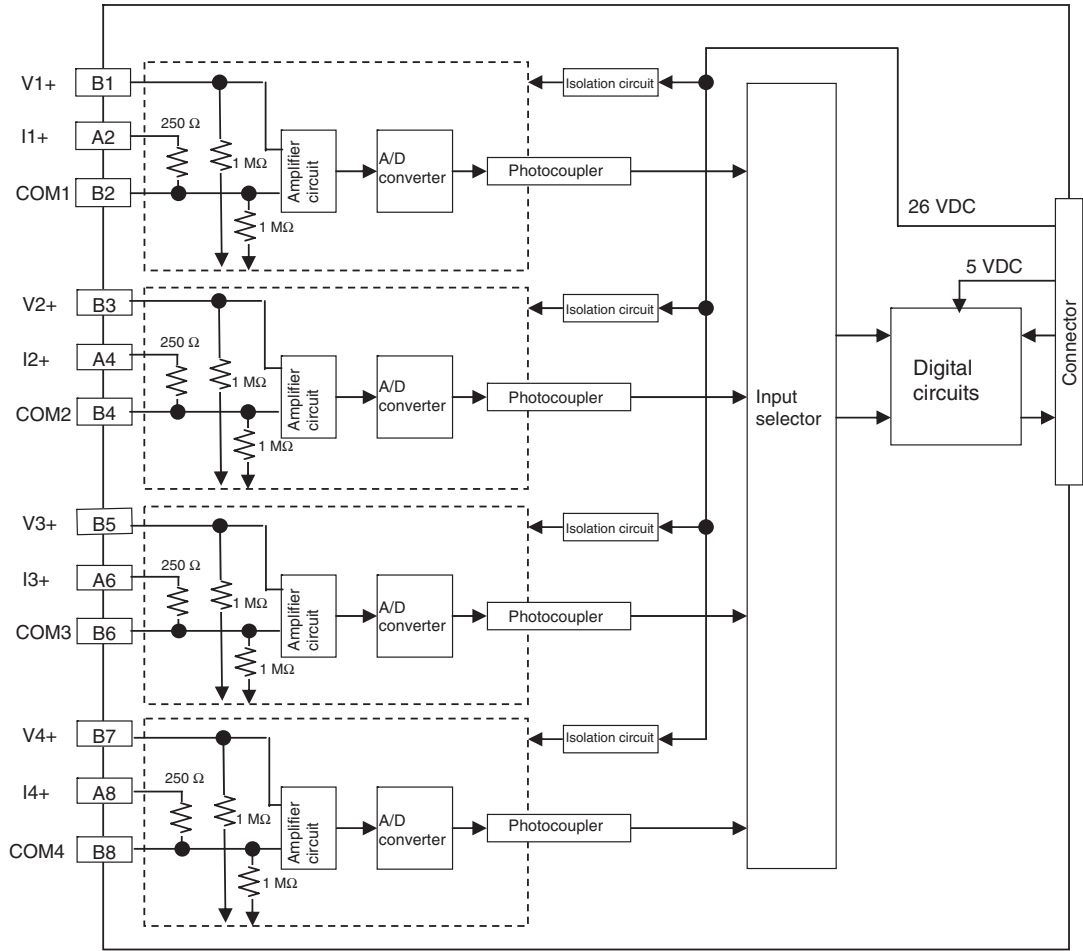

Error Processing

Conversion Data Does Not Change.

| Probable cause | Remedy |
|--|---|
| The gain for span adjustment is set to 0. | Set the gain for span adjustment to a value other than 0. |
| The minimum and maximum values for process value scaling are either the same or are set extremely low. | Set the minimum and maximum values correctly. |
| The input signal type or process value range is set incorrectly. | Check and reset the input signal type and the process value range settings. |
| An input device is malfunctioning, input wiring is faulty, or wiring is disconnected. | Check whether the input voltage or current has changed. Check for faulty or disconnected wiring. Check whether an input error has been detected in the I/O Area. |

Values are Not Converted as Intended.

| Probable cause | Remedy |
|--|---|
| The input signal type or process value scaling is set incorrectly. | Check and reset the input signal type and the process value scaling settings. |
| The zero/span adjustment data is incorrect. | Check and correct the zero/span adjustment settings. |
| The square root function is operating. | Set the square function so that it does not operate. |

Converted Values are Unstable.

| Probable cause | Remedy |
|--|---|
| Input signals are being affected by external noise. | Change the connection paths of the input signal lines. (Separate them from sources of noise or use shielded cable.) |
| | Insert 0.01- μ F to 0.1- μ F ceramic capacitors between the I+ and COM input terminals. |
| | Increase the number of values for calculating the moving average in mean value processing. |
| The scaling value is greater than the Unit's resolution. | Reduce the scaling value. |

2-13 CS1W-PDC55 Isolated-type Direct Current Input Unit

Overview

The CS1W-PDC55 Isolated-type Direct Current Input Unit provides 8 direct-current inputs, and sends the data to the CPU Unit each cycle. All inputs are isolated.

CS1W-PDC55

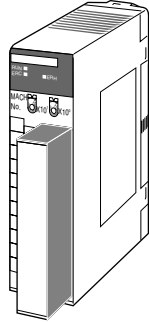

System Configuration

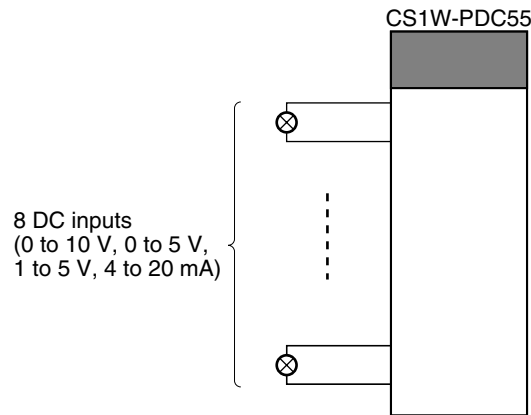

Features

- Up to 8 DC inputs can be made to each Unit.
0 to 10 V, 0 to 5 V, 1 to 5 V, 4 to 20 mA can be selected separately for each input.
- Scaling values are transmitted to the CPU Unit in four digits hexadecimal.
- There is isolation between channels, so unwanted signal paths between input signals can be prevented.
- Square root function.
- Process value alarms (Two internal alarms per input can be output to memory and two alarms per input can be output to specified I/O memory area addresses using indirect address specifications).
- Alarm ON-delay timer and hysteresis for process value.
- Zero/span adjustment capability during operation.
- Sensor error detection.
- Maximum or minimum process value can be specified for when a sensor error is detected.

Model Information

| Unit classification | Model number | Inputs | Input types |
|----------------------------|--------------|--------|---|
| CS-series Special I/O Unit | CS1W-PDC55 | 8 | 0 to 10 V, 0 to 5 V, 1 to 5 V, and 4 to 20 mA (separate for each input) |

Block Diagram

CPU Unit

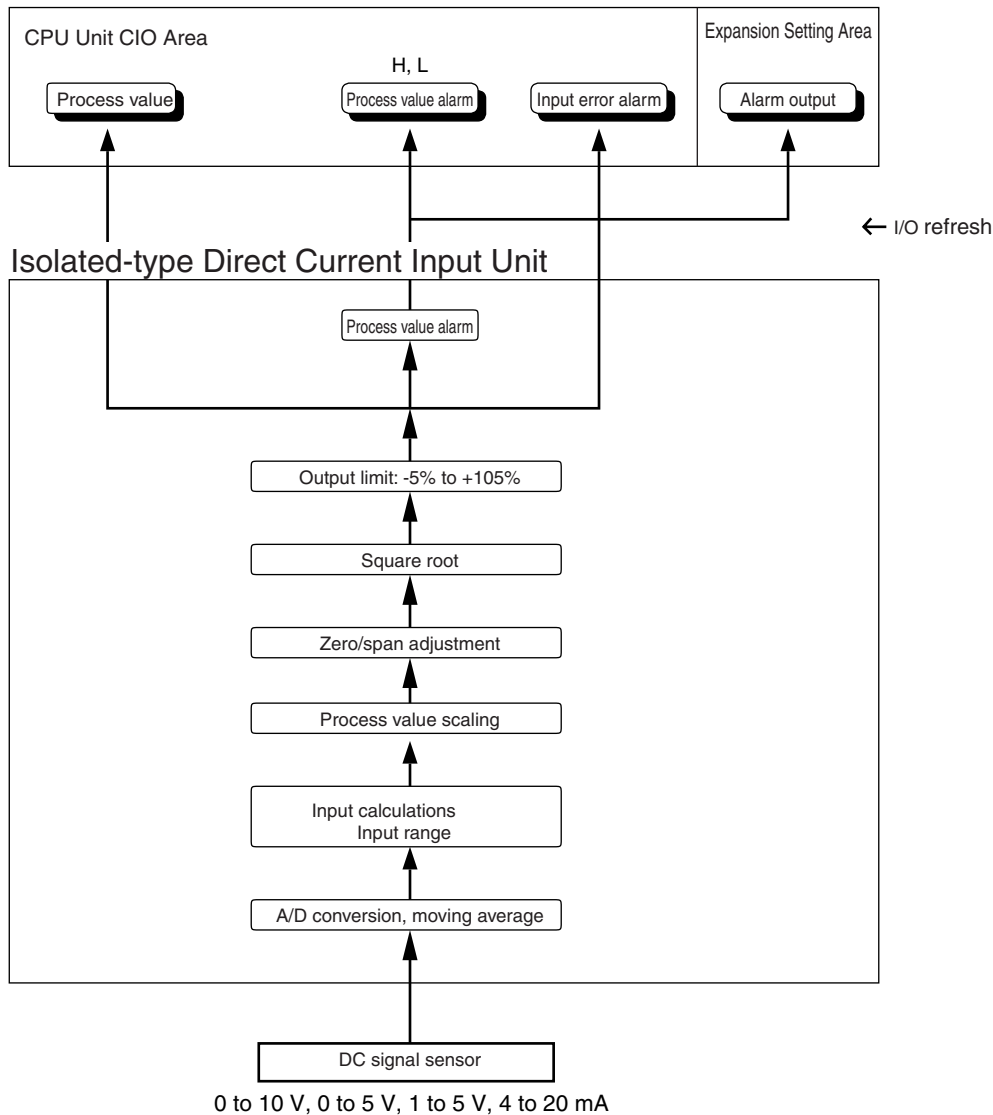

Specifications

| Item | Specifications |
|-------------------------|---|
| Model | CS1W-PDC55 |
| Applicable PLC | CS Series |
| Unit classification | CS-series Special I/O Unit |
| Mounting position | CS-series CPU Rack or CS-series Expansion Rack (Cannot be mounted to C200H Expansion I/O Rack or SYSMAC BUS Remote I/O Slave Rack.) |
| Maximum number of Units | 80 (within the allowable current consumption and power consumption range) |
| Unit numbers | 00 to 95 (Cannot duplicate Special I/O Unit numbers.) |

| Item | | Specifications |
|--|--|--|
| Areas for data exchange with CPU Unit | Special I/O Unit Area | 10 words/Unit Isolated-type Direct Current Input Unit to CPU Unit: All process values, process value alarms (L, H), conversion data enabled flags, input errors |
| | DM Area words allocated to Special I/O Units | 100 words/Unit CPU Unit to Isolated-type Direct Current Input Unit: Input signal type (separate for each input), process value alarm setting (L, H), zero/span adjustment value, Square root function. |
| | Expansion Control/Monitor Area | 1 word/Unit CPU Unit to Isolated-type Direct Current Input Unit: Process value alarms |
| Number of inputs | | 8 |
| Input signal type | 0 to 10 V, 0 to 5 V, 1 to 5 V, 4 to 20 mA (separate for each input). ("Not used" can be selected). | Input signal type and scaling to industrial units are separate for each of the 8 inputs. Note Input signal type and scaling to industrial units are set in the DM Area. Example: Input signal type: 4 to 20 mA; industrial unit scaling: 0 to 500 m ³ /h (after square root extraction). DM Area settings are as follows: Input signal type: 3 (0003 hex) Industrial unit maximum value stored: 500 (01F4 hex) Industrial unit minimum value stored: 0 (0000 hex) |
| Scaling | Data to be stored in the allocated words in the CIO area must be scaled (Any minimum and maximum values can be set.) (8 inputs set separately.) Data can be converted at 0% to 100%. | |
| Data storage in the CIO Area | The value derived from carrying out the following processing in order of the actual process data in the input range is stored in four digits hexadecimal (binary values) in the allocated words in the CIO Area. 1) Scaling → 2) Zero/span adjustment → 3) Square root calculation → 4) Output limits | |
| Accuracy (25°C) | ±0.3% of full scale | |
| Temperature Characteristics | For voltage inputs: 100 ppm/°C of full scale. For current inputs: 120 ppm/°C of full scale. | |
| Resolution | 1/16,000 of full scale | |
| Input signal range | For all inputs: -5 to +105% | |
| Input impedance | For current inputs: 250 Ω (typical) For voltage inputs: 1 MΩ min. | |
| Warmup time | 10 min | |
| Conversion period | 250 ms/8 inputs | |
| Maximum time to store data in CPU Unit | Conversion period + one CPU Unit cycle | |
| Input error detection | Detects sensor error at each input and turns ON the Sensor error Flag. The process value overrange direction for when a sensor error occurs can be specified. (High: 105% of input range; low: -5% of input range) | |
| Function | Process value alarm | Process value 8-point alarm (L H), hysteresis, and ON-delay timer (0 to 60 s) are available. Two alarms per input (L, H) can be output to addresses in the CIO Area specified in the Expansion Setting Area. |
| | Square root calculation (Supported only when input is 1 to 5 v or 4 to 20 mA.) | When the maximum value for process value scaling is A and the minimum value is B, $\text{Output} = \sqrt{(A - B) \times (\text{input} - B) + B}$ Drop-out: Output approx. 7% max. linear (output = input) characteristic Note 1 The square root function can only be used when the maximum scaling value is greater than the minimum scaling value. The square root will not be found if the maximum is smaller than the minimum. Note 2 When the square root function is used, set the scaling values after square root calculation (e.g., for flow rates or other values) for the process value scaling A and B settings. |

| Item | Specifications |
|-------------------------------|---|
| Isolation | Between inputs and between inputs and PLC signals: Isolation by transformer and photocoupler. |
| Insulation resistance | 20 MΩ max. (at 500 V DC). Between all input terminals and external AC terminals (Power Supply Unit) Between all input terminals and FG plate |
| Dielectric strength | Between all input terminals and external AC terminals (Power Supply Unit) Between all input terminals and FG plate 1,000 VAC, 50/60 Hz 1 min., detection current: 1 mA Between all channels 500 VAC, 50/60 Hz 1 min., detection current: 1 mA |
| External connections | Terminal block (detachable) |
| Unit number settings | Set by rotary switches on front panel, from 0 to 95. |
| Indicators | Three LED indicators on front panel (for normal operation, errors detected at the Direct Current Input Unit, and errors detected at the CPU Unit). |
| Front panel connector | Sensor input connector terminal block (detachable) |
| Effect on CPU Unit cycle time | 0.4 ms |
| Current consumption | 5 V DC at 180 mA max., 26 V DC at 60 mA max. |
| Dimensions | 35 × 130 × 126 mm (W × H × D) Note The height including the Backplane is 145 mm. |
| Weight | 450 g max. |

DM Area Allocations

First word: word m. m = D20000 + unit number × 100 (unit number: 0 to 95)

| DM Area address | | | | | | | | Data range | | Default | Data contents |
|---|-------------|-------------|-------------|-------------|-------------|-------------|-------------|--------------------------------|------------------|--|--|
| Input No. 1 | Input No. 2 | Input No. 3 | Input No. 4 | Input No. 5 | Input No. 6 | Input No. 7 | Input No. 8 | Decimal | Hexadecimal | | |
| m | | | | | | | | 12345, 0 | 3039, 0000 hex | 0000 hex | Default block read command Specifies the direction of data transfer when the PLC is turned ON or the Unit is restarted for DM Area words m+1 to m+97. <ul style="list-style-type: none"> 12345 (3039 hex): The data in words m+2 to m+98 is transferred from the Direct Current Input Unit to the CPU Unit. When the transfer is completed, the value will become 0000 hex. Other than 12345 (such as 0000 hex): The data in the allocated words of DM Area is transferred from the CPU Unit to the Direct Current Input Unit. |
| Display parameter | | | | | | | | | | | |
| m+1 | | | | | | | | 0 to 83 | 0000 to 0053 hex | 0 (0000 hex) | Address of Data Range Error (See note 1.) |
| Setting Group 1 (continuously refreshed area): Parameters that are continuously refreshed during PLC operation (regardless of the CPU Unit's operation mode) | | | | | | | | | | | |
| | | | | | | | | | | Process value alarm settings | |
| m+2 | m+6 | m+10 | m+14 | m+18 | m+22 | m+26 | m+30 | Low to high limit for sensors. | 4200 (1068 hex) | Process value H (high limit) alarm setting | |
| m+3 | m+7 | m+11 | m+15 | m+19 | m+23 | m+27 | m+31 | | -200 (FF38 hex) | Process value L (low limit) alarm setting | |
| | | | | | | | | | | Span adjustment value | |
| m+4 | m+8 | m+12 | m+16 | m+20 | m+24 | m+28 | m+32 | 0 to 32000 | 0000 to 7D00 hex | 10000 (2710 hex) | Set value × 0.0001 |
| | | | | | | | | | | Zero adjustment value | |
| m+5 | m+9 | m+13 | m+17 | m+21 | m+25 | m+29 | m+33 | -9999 to 9999 | D8F1 to 270F hex | 0 (0000 hex) | Set value × 0.1 |

| DM Area address | | | | | | | | Data range | | Default | Data contents |
|--|-------------|-------------|-------------|-------------|-------------|-------------|-------------|-----------------|------------------------------------|---|--|
| Input No. 1 | Input No. 2 | Input No. 3 | Input No. 4 | Input No. 5 | Input No. 6 | Input No. 7 | Input No. 8 | Decimal | Hexadecimal | | |
| Setting Group 2 (initial settings area): Parameters that are transferred one time from the CPU Unit to the Direct Current Input Unit if word m contains other than 12345 when the PLC is turned ON or the Direct Current Input Unit is restarted. | | | | | | | | | | | |
| | | | | | | | | | | Operation settings (See note 2.) | |
| m+34 | | | | | | | | (See note 2.) | (See note 2.) | 0 (0000 hex) | 04: Data display (binary or BCD) 08: Minus sign display format for BCD display 12: Data direction at sensor error 13: Data held at sensor error |
| | | | | | | | | | | Input signal type | |
| m+35 | m+41 | m+47 | m+53 | m+59 | m+65 | m+71 | m+77 | 0 to 3, 15 | 0000 to 0003, 000F hex | 0 (0000 hex) | 0: 0 to 10 V; 1: 0 to 5 V; 2: 1 to 5 V; 3: 4 to 20 mA; F: Not used |
| | | | | | | | | | | Alarm hysteresis | |
| m+36 | m+42 | m+48 | m+54 | m+60 | m+66 | m+72 | m+78 | 0 to 9999 | 0000 to 270F hex | 0 (0000 hex) | Set value × 0.1 |
| | | | | | | | | | | Alarm ON-delay time | |
| m+37 | m+43 | m+49 | m+55 | m+61 | m+67 | m+73 | m+79 | 0 to 60 | 0000 to 003C hex | 0 (0000 hex) | Unit: s |
| | | | | | | | | | | Square root function (Supported only when input is 1 to 5 V or 4 to 20 mA.) | |
| m+38 | m+44 | m+50 | m+56 | m+62 | m+68 | m+74 | m+80 | 0, 1 | 0000, 0001 hex | 0 (0000 hex) | Square root extraction (when maximum scaling value > minimum scaling value) 0: Disable; 1: Enable |
| | | | | | | | | | | Process value scaling | |
| m+39 | m+45 | m+51 | m+57 | m+63 | m+69 | m+75 | m+81 | -32000 to 32000 | 8300 to FFFF hex, 0000 to 7D00 hex | 4000 (0FA0 hex) | Value stored for maximum value in range (span) |
| m+40 | m+46 | m+52 | m+58 | m+64 | m+70 | m+76 | m+82 | -32000 to 32000 | 8300 to FFFF hex, 0000 to 7D00 hex | 0 (0000 hex) | Value stored for minimum value in range (zero) |
| | | | | | | | | | | Expansion Setting Area enable | |
| m+83 | | | | | | | | 0, 1 | 0000, 0001 hex | 0 (0000 hex) | 0: Disabled 1: Enabled |
| | | | | | | | | | | Expansion Setting Area address | |
| m+84 (See note 3.) | | | | | | | | 0 to 6143 | 0000 to 17FF hex | 0 (0000 hex) | CIO area (fixed) Number of words. |

- Note**
1. The ERC indicator on the Unit's front panel will light if an out-of-range setting is made in either Setting Group 1 (continuously refreshed area) or 2 (initial settings area). The offset from word m to the first word containing the out-of-range error will be stored as the Address of Data Range Error in the DM Area in four digits hexadecimal.
 2. The operation settings are shown in the following table

3. A range check is not performed for the Expansion Setting Area address set in word m+84. Be sure to check this address before starting actual operation.

| Word | Bits | Description | Settings |
|------|------|---|---|
| m+34 | 04 | Data format | 0: Binary (Negative values are given as 2's complements). 1: BCD |
| | 08 | Minus sign display format for BCD display | 0: "F" used to indicate the minus sign. 1: Leftmost bit used to indicate the minus sign. The setting is disabled if bits 04 to 07 are set to 0. |
| | 12 | Data direction at sensor error | 0: Goes to upper limit at sensor error 1: Goes to lower limit at sensor error |
| | 13 | Data held at sensor error | 0: Follow the setting of Data direction at sensor error 1: If there is a sensor error when the upper limit is exceeded, hold the data at the upper limit. If there is a sensor error when the lower limit is exceeded, hold the data at the lower limit. |

Example: For a binary data format and a data direction at sensor error of "lower limit," word m+18 contains 1000.

Expansion Setting Area

First word: word o. (o = address specified in word m+60 in the DM Area)

| Direction | Word | Bit | Name | | Data range | Contents |
|---------------------------------------|------|-----|-------------|------------------------------------|------------|--|
| Direct Current Input Unit to CPU Unit | o | 00 | Input No. 1 | Process value L (low limit) alarm | 0, 1 | 0: Process value > Set value 1: Process value ≤ Set value |
| | | 01 | | Process value H (high limit) alarm | 0, 1 | 0: Process value < Set value 1: Process value ≥ Set value |
| | | 02 | Input No. 2 | Process value L (low limit) alarm | 0, 1 | Same as for input No. 1. |
| | | 03 | | Process value H (high limit) alarm | 0, 1 | |
| | | 04 | Input No. 3 | Process value L (low limit) alarm | 0, 1 | |
| | | 05 | | Process value H (high limit) alarm | 0, 1 | |
| | | 06 | Input No. 4 | Process value L (low limit) alarm | 0, 1 | |
| | | 07 | | Process value H (high limit) alarm | 0, 1 | |
| | | 08 | Input No. 5 | Process value L (low limit) alarm | 0, 1 | |
| | | 09 | | Process value H (high limit) alarm | 0, 1 | |
| | | 10 | Input No. 6 | Process value L (low limit) alarm | 0, 1 | |
| | | 11 | | Process value H (high limit) alarm | 0, 1 | |
| | | 12 | Input No. 7 | Process value L (low limit) alarm | 0, 1 | |
| | | 13 | | Process value H (high limit) alarm | 0, 1 | |
| | | 14 | Input No. 8 | Process value L (low limit) alarm | 0, 1 | |
| | | 15 | | Process value H (high limit) alarm | 0, 1 | |

Note If either of the following changes is made for the Expansion Setting Area for the CS1W-PTS55/PTS56/PDC55, the previous data will be left in the Expansion Setting Area even after the change has been made.
Clear the previous data when changing either of these settings.

- The Expansion Setting Area Enable setting is changed from “enabled” to “disabled.”
- The Expansion Setting Area Address setting is changed while the Expansion Setting Area Enable setting is set to “enabled.”

CIO Area Allocations

First word: n = 2000 + unit number × 10 (unit number: 0 to 95)

| Direction | Word | Bit | Name | | Data range | Contents |
|---------------------------------------|----------|-------------|---------------|------------------------------------|---|--|
| Direct Current Input Unit to CPU Unit | n | 00 | Input No. 1 | Process value L (low limit) alarm | 0, 1 | 0: Process value > Set value 1: Process value ≤ Set value |
| | | 01 | | Process value H (high limit) alarm | 0, 1 | 0: Process value < Set value 1: Process value ≥ Set value |
| | | 02 | Input No. 2 | Process value L (low limit) alarm | 0, 1 | Same as for input No. 1. |
| | | 03 | | Process value H (high limit) alarm | 0, 1 | |
| | | 04 | Input No. 3 | Process value L (low limit) alarm | 0, 1 | |
| | | 05 | | Process value H (high limit) alarm | 0, 1 | |
| | | 06 | Input No. 4 | Process value L (low limit) alarm | 0, 1 | |
| | | 07 | | Process value H (high limit) alarm | 0, 1 | |
| | | 08 | Input No. 5 | Process value L (low limit) alarm | 0, 1 | |
| | | 09 | | Process value H (high limit) alarm | 0, 1 | |
| | | 10 | Input No. 6 | Process value L (low limit) alarm | 0, 1 | |
| | | 11 | | Process value H (high limit) alarm | 0, 1 | |
| | | 12 | Input No. 7 | Process value L (low limit) alarm | 0, 1 | |
| | | 13 | | Process value H (high limit) alarm | 0, 1 | |
| | | 14 | Input No. 8 | Process value L (low limit) alarm | 0, 1 | |
| | | 15 | | Process value H (high limit) alarm | 0, 1 | |
| n + 1 | 00 to 15 | Input No. 1 | Process value | Depends on type of input. | The integral value for the present value is stored according to the scaling set in the DM Area. | |
| n + 2 | 00 to 15 | Input No. 2 | | | | |
| n + 3 | 00 to 15 | Input No. 3 | | | | |
| n + 4 | 00 to 15 | Input No. 4 | | | | |
| n + 5 | 00 to 15 | Input No. 5 | | | | |
| n + 6 | 00 to 15 | Input No. 6 | | | | |
| n + 7 | 00 to 15 | Input No. 7 | | | | |
| n + 8 | 00 to 15 | Input No. 8 | | | | |

| Direction | Word | Bit | Name | Data range | Contents | | |
|---------------------------------------|-------|----------|--|--------------|----------|-----------------------|-------------------------------------|
| Direct Current Input Unit to CPU Unit | n + 9 | 00 | Input No. 1 | Sensor error | 0, 1 | 0: Normal 1: Error | |
| | | 01 | Input No. 2 | | 0, 1 | | |
| | | 02 | Input No. 3 | | 0, 1 | | |
| | | 03 | Input No. 4 | | 0, 1 | | |
| | | 04 | Input No. 5 | | 0, 1 | | |
| | | 05 | Input No. 6 | | 0, 1 | | |
| | | 06 | Input No. 7 | | 0, 1 | | |
| | | 07 | Input No. 8 | | 0, 1 | | |
| | | 08 to 14 | Not used. | | | | |
| | | 15 | Conversion data enabled flag (See note.) | | | 0, 1 | 0: Data disabled 1: Data enabled |

- Note**
1. The Conversion Data Enabled Flag remains OFF after the PLC is turned ON or the Unit is restarted until the AD conversion data becomes stable (approximately 2 to 4 s), then is ON during operation.
 2. When the default settings are transferred, the upper and lower limits for the process value alarms will be the same as the input error detection levels. If the upper or lower limit is exceeded in this condition, a process value alarm will not be output and only an input error will be detected.

Terminal Connection Diagram

Voltage Inputs

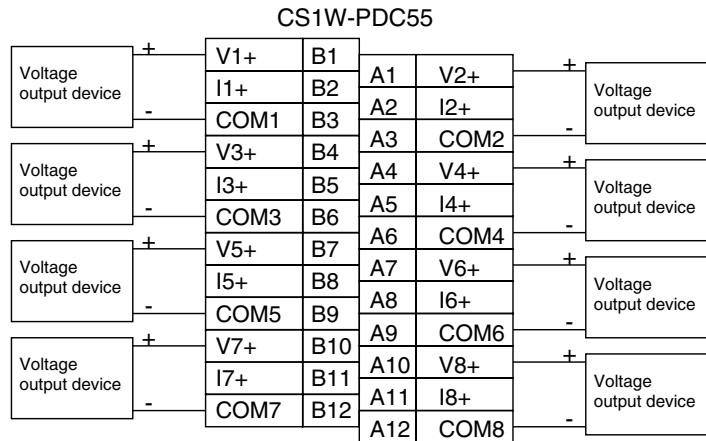

Current inputs

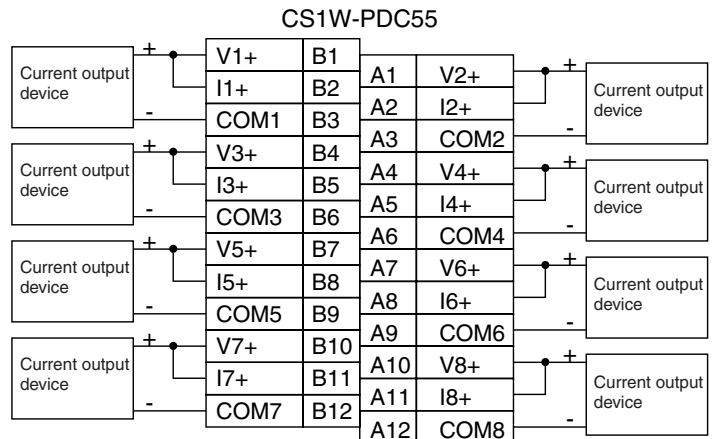

- Note**
- In both of the above cases, leave all unused inputs open between the positive and negative terminals.
 - Always short-circuit the V and I terminals when using current input.

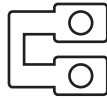

- Be sure to tighten the short bars to a torque of 0.5 N·m. Loose short bars may result in conversion errors.
- Always ground the GR terminal on the Power Supply Unit of the PLC.
- If the input device uses a voltage generator, temperature compensator, or similar device, then ground the input device if it has a ground terminal.

Terminal Block Diagram

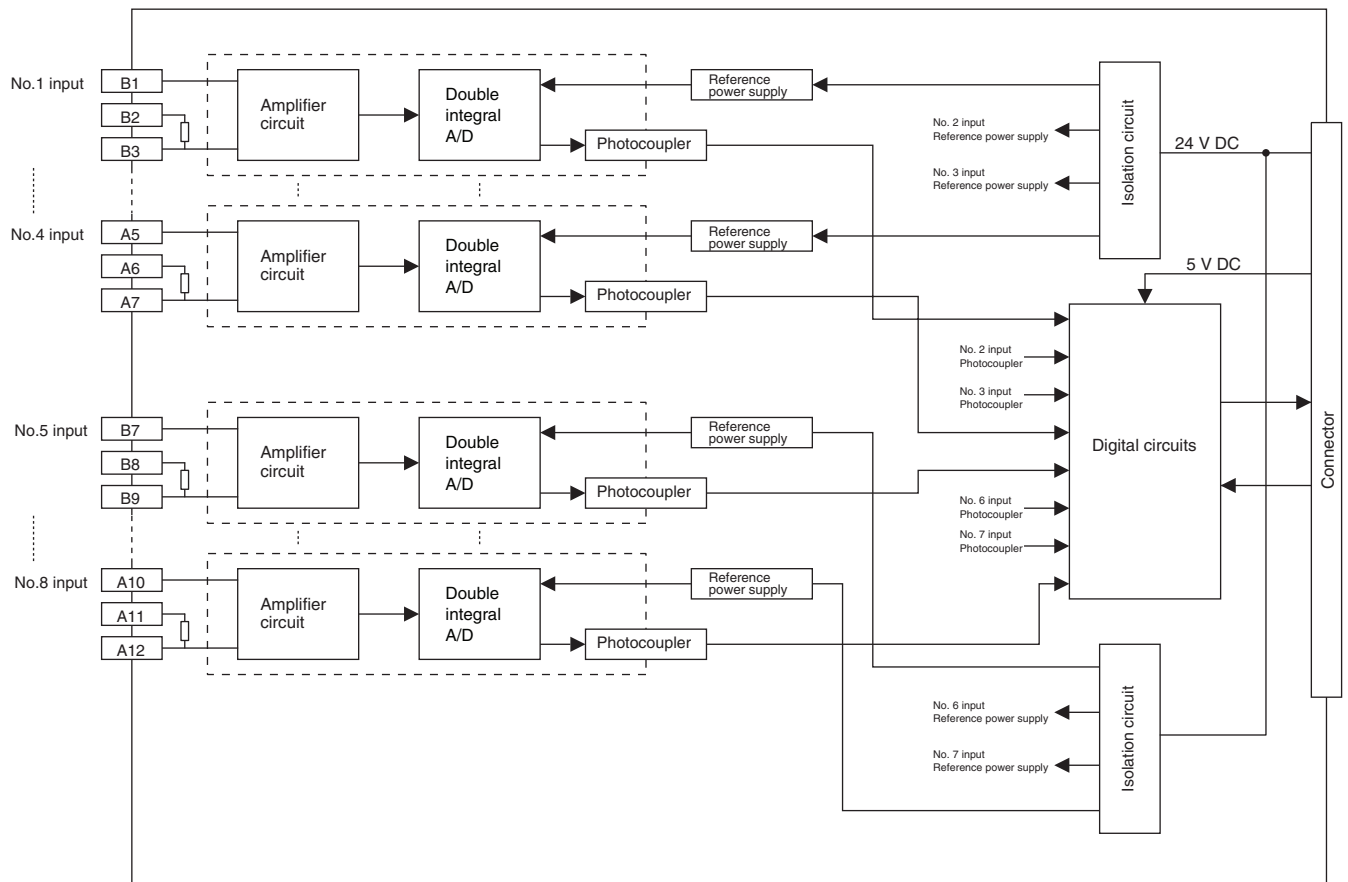

Error Processing

Conversion Data Does Not Change.

| Probable cause | Remedy |
|--|---|
| The gain for span adjustment is set to 0. | Set the gain for span adjustment to a value other than 0. |
| The minimum and maximum values for process value scaling are either the same or are set extremely low. | Set the minimum and maximum values correctly. |
| The input signal type or process value range is set incorrectly. | Check and reset the input signal type and the process value range settings. |
| An input device is malfunctioning, input wiring is faulty, or wiring is disconnected. | Check whether the input voltage or current has changed. Check for faulty or disconnected wiring. Check whether an input error has been detected in the I/O Area. |

Values are Not Converted as Intended.

| Probable cause | Remedy |
|--|---|
| The input signal type or process value scaling is set incorrectly. | Check and reset the input signal type and the process value scaling settings. |
| The zero/span adjustment data is incorrect. | Check and correct the zero/span adjustment settings. |
| The square root function is operating. | Set the square function so that it does not operate. |

Converted Values are Unstable.

| Probable cause | Remedy |
|--|---|
| Input signals are being affected by external noise. | Change the connection paths of the input signal lines. (Separate them from sources of noise or use shielded cable.) |
| | Insert 0.01- μ F to 0.1- μ F ceramic capacitors between the I+ and COM input terminals. |
| | Increase the number of values for calculating the moving average in mean value processing. |
| The scaling value is greater than the Unit's resolution. | Reduce the scaling value. |

2-14 CS1W-PTR01 Power Transducer Input Unit

Overview

The CS1W-PTR01 Power Transducer Input Unit provides up to eight inputs of 0 to 1 mA or -1 to 1 mA from power transducers, and sends the data to the CPU Unit each cycle.

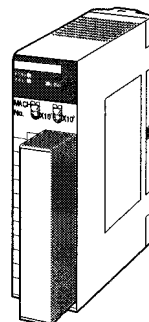

CS1W-PTR01

System Configuration

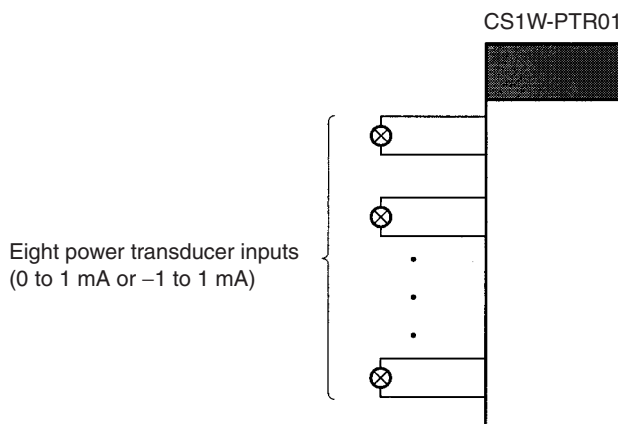

Features

- Up to eight inputs of 0 to 1 mA or -1 to 1 mA from a power transducer can be separately connected.
- Scaling values are sent to the CPU Unit in four digits hexadecimal.
- The inrush input limit function temporarily limits the process value input to a given set value when it increases from a low value (2%), in order to prevent process values from being jumped up by an inrush current when the motor is started up, and so on. (This function is available for inputs of 0 to 1 mA only.)
- Two values for each process value alarm input.
- ON-delay timer for process value alarm.
- Mean value processing (for four values).
- Zero/span adjustment capability during operation.

Model Information

| Unit classification | Model number | Inputs | Input types |
|----------------------------|--------------|--------|--|
| CS-series Special I/O Unit | CS1W-PTR01 | 8 | Either of the following can be selected separately: 0 to 1 mA, or -1 to 1 mA. |

Block Diagram (Order of Processing)

The processing for the eight inputs is as shown in the following diagram.

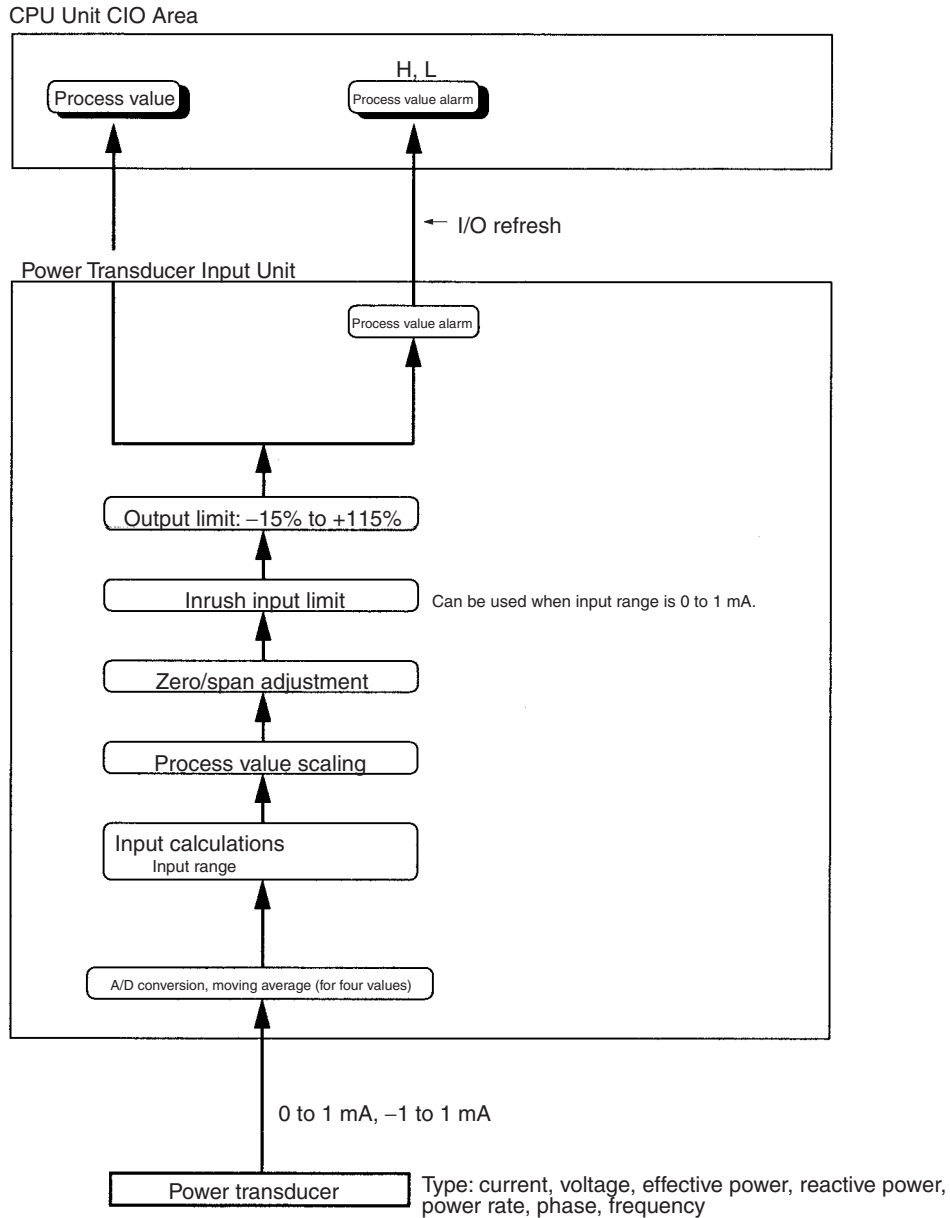

Specifications

| Item | Specifications |
|-------------------------|---|
| Model | CS1W-PTR01 |
| Applicable PLC | CS Series |
| Unit classification | CS-series Special I/O Unit |
| Mounting position | CS-series CPU Rack or CS-series Expansion Rack (Cannot be mounted to C200H Expansion I/O Rack or SYSMAC BUS Remote I/O Slave Rack.) |
| Maximum number of Units | 80 (within the allowable current consumption and power consumption range) |
| Unit numbers | 00 to 95 (Cannot duplicate Special I/O Unit numbers.) |

| Item | | Specifications |
|--|--|---|
| Areas for data exchange with CPU Unit | Special I/O Unit Area | 10 words/Unit Power Transducer Input Unit to CPU Unit: All process values, process value alarms (L, H) |
| | DM Area words allocated to Special I/O Units | 100 words/Unit CPU Unit to Power Transducer Input Unit: Input signal type, scaling of process value in industrial units, process value alarm setting (L, H), inrush input upper limit, inrush input upper limit time, zero/span adjustment value, etc. |
| Number of inputs | | 8 |
| Input signal type | | Either 0 to 1 mA or -1 to 1 mA. |
| User-defined scaling in industrial units | | Scaling required for the above input signals. (Any minimum and maximum values can be set.) (8 inputs set separately.) |
| Data storage in the CIO Area | | The value derived from carrying out the following processing in order of the process value data is stored in four digits hexadecimal (binary values) in the allocated words in the CIO Area. 1) Mean value processing → 2) Scaling → 3) Zero/span adjustment → 4) Inrush input limit → 5) Output limits |
| | | Input signal type and scaling to industrial units are separate for each of the 8 inputs. Note Input signal type and scaling to industrial units are set in the DM Area. Example: Input signal type: 0 to 1 mA from power transducer; industrial unit scaling: 0 to 500 W. DM Area settings are as follows: Input signal type: 0 (0000 hex) Industrial unit maximum value stored: 500 (01F4 hex) Industrial unit minimum value stored: 0 (0000 hex) |
| Accuracy (25°C) | | ±0.2% of full scale |
| Temperature coefficient | | ±0.015%/°C of full scale |
| Resolution | | 1/4,096 of full scale |
| Input signal range | | For 0 to 1 mA: -15 to 115%; for -1 to 1 mA: -7.5 to 107.5% |
| Input impedance | | 100 Ω (typical) |
| Warmup time | | 10 min |
| Response time | | 1.2 s (travel time from input 0% to 90%, for step input) |
| Conversion period | | 200 ms/8 inputs |
| Maximum time to store data in CPU Unit | | Conversion period + one CPU Unit cycle |
| Input error detection | | None. |
| Operation at input disconnection | | Process value corresponding to 0 mA stored. |
| Function | Inrush input limit | When the process value is increased from 2% or less, the inrush input limit function limits the increase for a set time. (It is available only for inputs of 0 to 1 mA.) This function can be used to prevent sudden process value increases due to inrush currents caused by motor startup and so on. Upper limit value: -32,000 to 32,000 Upper limit time: 0 to 100 s |
| | Process value alarm | Process value 2-point alarm (H, L), hysteresis, and ON-delay timer (0 to 60 s) are available. |
| | Mean value processing (input filter) | Calculates the moving average for the past four process values (every 200 ms), and stores that value in the CIO Area as the process value. |
| Isolation | | Between inputs: No isolation Between input terminals and PLC signals: Isolation by transformer and photocoupler |
| Insulation resistance | | 20 MΩ (at 500 V DC) between inputs and internal PLC signals |
| Dielectric strength | | Between inputs and internal PLC signals: 1,000 V AC, at 50/60 Hz, for 1 min, leakage current 10 mA max. |
| External connections | | Terminal block (detachable) |
| Unit number settings | | Set by rotary switches on front panel, from 0 to 95. |
| Indicators | | Three LED indicators on front panel (for normal operation, errors detected at the Power Transducer Input Unit, and errors related to the CPU Unit). |

| Item | Specifications |
|-------------------------------|--|
| Front panel connector | Sensor input connector terminal block (detachable) |
| Effect on CPU Unit cycle time | 0.3 ms |
| Current consumption | 5 V DC at 150 mA max., 26 V DC at 80 mA max. |
| Dimensions | 35 × 130 × 126 mm (W × H × D) Note The height including the Backplane is 145 mm. |
| Weight | 450 g max. |
| Standard accessories | None |

DM Area Allocations

m = D20000 + unit number × 100 (unit number: 0 to 95)

| DM Area address | | | | | | | | Data range | | Default | Data contents |
|--|-------------|-------------|-------------|-------------|-------------|-------------|-------------|-----------------|------------------------------------|--------------------------------------|--|
| Input No. 1 | Input No. 2 | Input No. 3 | Input No. 4 | Input No. 5 | Input No. 6 | Input No. 7 | Input No. 8 | Decimal | Hexadecimal | | |
| m | | | | | | | | 12345, 0 | 3039, 0000 hex | 0000 hex | Default block read command Specifies the direction of data transfer when the PLC is turned ON or the Unit is restarted for DM words m+2 to m+89. <ul style="list-style-type: none"> 12345 (3039 hex): The data in words m+2 to m+89 is transferred from the Power Transducer Input Unit to the CPU Unit. When the transfer is completed, the value will become 0000 hex. Other than 12345 (3039 hex) (such as 0000 hex): The data in the allocated words of DM Area is transferred from the CPU Unit to the Power Transducer Input Unit. |
| Setting Group 1 (continuously refreshed area): Parameters that are continuously refreshed during PLC operation (regardless of the CPU Unit's operation mode) | | | | | | | | | | | |
| | | | | | | | | | | Process value alarm settings | |
| m + 2 | m + 6 | m + 10 | m + 14 | m + 18 | m + 22 | m + 26 | m + 30 | -32768 to 32767 | 8000 to FFFF hex, 0000 to 7FFF hex | 4200 (0FA0 hex) | Process value H (high limit) alarm setting (Set at process value scaling value.) |
| m + 3 | m + 7 | m + 11 | m + 15 | m + 19 | m + 23 | m + 27 | m + 31 | -32768 to 32767 | 8000 to FFFF hex, 0000 to 7FFF hex | 0 (0000 hex) | Process value L (low limit) alarm setting (Set at process value scaling value.) |
| | | | | | | | | | | Zero/span adjustment | |
| m + 4 | m + 8 | m + 12 | m + 16 | m + 20 | m + 24 | m + 28 | m + 32 | 0 to 32000 | 0000 to 7D00 hex | 10000 (2710 hex) | Gain for span adjustment (set value × 0.0001) |
| m + 5 | m + 9 | m + 13 | m + 17 | m + 21 | m + 25 | m + 29 | m + 33 | -32000 to 32000 | 8300 to FFFF hex, 0000 to 7D00 hex | 0 (0000 hex) | Zero adjustment value (Set at process value scaling value.) |
| Setting Group 2 (initial settings area): Parameters that are transferred one time from the CPU Unit to the Power Transducer Input Unit if word m contains other than 12345 when the PLC is turned ON or the Power Transducer Input Unit is restarted. | | | | | | | | | | | |
| m + 34 | m + 41 | m + 48 | m + 55 | m + 62 | m + 69 | m + 76 | m + 83 | 0, 1 | 0000 to 0001 hex | 0 (0000 hex) | Input signal type 0: 0 to 1 mA 1: -1 to 1 mA |
| | | | | | | | | | | Process value scaling | |
| m + 35 | m + 42 | m + 49 | m + 56 | m + 63 | m + 70 | m + 77 | m + 84 | -32000 to 32000 | 8300 to FFFF hex, 0000 to 7D00 hex | 4000 (0FA0 hex) | Value stored for maximum value in range (span) |
| m + 36 | m + 43 | m + 50 | m + 57 | m + 64 | m + 71 | m + 78 | m + 85 | -32000 to 32000 | 8300 to FFFF hex, 0000 to 7D00 hex | 0 (0000 hex) | Value stored for minimum value in range (zero) |
| | | | | | | | | | | Alarm supplementary functions | |
| m + 37 | m + 44 | m + 51 | m + 58 | m + 65 | m + 72 | m + 79 | m + 86 | 0 to 32000 | 0000 to 7D00 hex | 40 (0028 hex) | Alarm hysteresis (Set at process value scaling value.) |
| m + 38 | m + 45 | m + 52 | m + 59 | m + 66 | m + 73 | m + 80 | m + 87 | 0 to 60 | 0000 to 003C hex | 0 (0000 hex) | Alarm ON-delay time (Unit: s) |

| DM Area address | | | | | | | | Data range | | Default | Data contents |
|--------------------------|-------------|-------------|-------------|-------------|-------------|-------------|-------------|-----------------|------------------------------------|------------------------------------|--|
| Input No. 1 | Input No. 2 | Input No. 3 | Input No. 4 | Input No. 5 | Input No. 6 | Input No. 7 | Input No. 8 | Decimal | Hexadecimal | | |
| | | | | | | | | | | Inrush input limit function | |
| m + 39 | m + 46 | m + 53 | m + 60 | m + 67 | m + 74 | m + 81 | m + 88 | 0 to 100 | 0000 to 0064 hex | 0 (0000 hex) | Inrush upper limit time (Unit: s) 0: No limit |
| m + 40 | m + 47 | m + 54 | m + 61 | m + 68 | m + 75 | m + 82 | m + 89 | -32000 to 32000 | 8300 to FFFF hex, 0000 to 7D00 hex | 4000 (0FA0 hex) | Inrush upper limit value |
| Storage parameter | | | | | | | | | | | |
| m + 90 | m + 91 | m + 92 | m + 93 | m + 94 | m + 95 | m + 96 | m + 97 | 0 to 89 | 0000 to 0059 hex | 0 (0000 hex) | Address of Data Range Error (See note.) |

Note The ERC indicator on the Unit's front panel will light if an out-of-range setting is made in either Setting Group 1 or 2. The offset from word m to the first word containing the out-of-range error will be stored as the Address of Data Range Error in the DM Area in four digits hexadecimal. For more information, refer to *1-6 Error Processing*.

CIO Area Allocations

n = 2000 + unit number × 10 (unit number: 0 to 95)

| Direction | Word | Bit | Name | | Data range | Contents |
|---|------|-----|-------------|------------------------------------|------------|--|
| Power Transducer Input Unit to CPU Unit | n | 00 | Input No. 1 | Process value L (low limit) alarm | 0, 1 | 0: Process value > Set value 1: Process value ≤ Set value |
| | | 01 | | Process value H (high limit) alarm | 0, 1 | 0: Process value < Set value 1: Process value ≥ Set value |
| | | 02 | Input No. 2 | Process value L (low limit) alarm | 0, 1 | Same as for input No. 1. |
| | | 03 | | Process value H (high limit) alarm | 0, 1 | |
| | | 04 | Input No. 3 | Process value L (low limit) alarm | 0, 1 | Same as for input No. 1. |
| | | 05 | | Process value H (high limit) alarm | 0, 1 | |
| | | 06 | Input No. 4 | Process value L (low limit) alarm | 0, 1 | Same as for input No. 1. |
| | | 07 | | Process value H (high limit) alarm | 0, 1 | |
| | | 08 | Input No. 5 | Process value L (low limit) alarm | 0, 1 | Same as for input No. 1. |
| | | 09 | | Process value H (high limit) alarm | 0, 1 | |
| | | 10 | Input No. 6 | Process value L (low limit) alarm | 0, 1 | Same as for input No. 1. |
| | | 11 | | Process value H (high limit) alarm | 0, 1 | |
| | | 12 | Input No. 7 | Process value L (low limit) alarm | 0, 1 | Same as for input No. 1. |
| | | 13 | | Process value H (high limit) alarm | 0, 1 | |
| | | 14 | Input No. 8 | Process value L (low limit) alarm | 0, 1 | Same as for input No. 1. |
| | | 15 | | Process value H (high limit) alarm | 0, 1 | |

| Direction | Word | Bit | Name | Data range | Contents |
|---|-------|----------|---------------------------|--|---|
| Power Transducer Input Unit to CPU Unit | n + 1 | 00 to 15 | Input No. 1 process value | -32768 to 32767 (8000 to FFFF hex, 0000 to 7FFF hex) | The present process value is stored according to the scaling set in the allocated words of the DM Area. |
| | n + 2 | 00 to 15 | Input No. 2 process value | -32768 to 32767 (8000 to FFFF hex, 0000 to 7FFF hex) | |
| | n + 3 | 00 to 15 | Input No. 3 process value | -32768 to 32767 (8000 to FFFF hex, 0000 to 7FFF hex) | |
| | n + 4 | 00 to 15 | Input No. 4 process value | -32768 to 32767 (8000 to FFFF hex, 0000 to 7FFF hex) | |
| | n + 5 | 00 to 15 | Input No. 5 process value | -32768 to 32767 (8000 to FFFF hex, 0000 to 7FFF hex) | |
| | n + 6 | 00 to 15 | Input No. 6 process value | -32768 to 32767 (8000 to FFFF hex, 0000 to 7FFF hex) | |
| | n + 7 | 00 to 15 | Input No. 7 process value | -32768 to 32767 (8000 to FFFF hex, 0000 to 7FFF hex) | |
| | n + 8 | 00 to 15 | Input No. 8 process value | -32768 to 32767 (8000 to FFFF hex, 0000 to 7FFF hex) | |

Terminal Connection Diagram

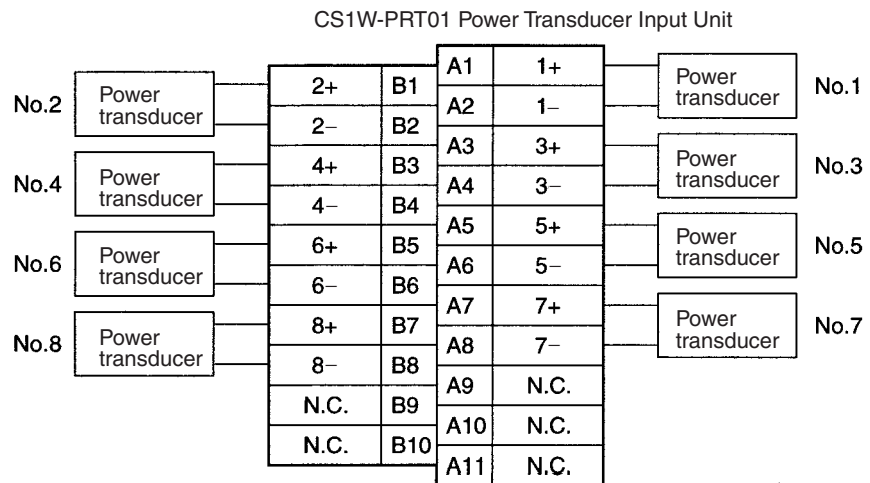

Note Leave all unused inputs open between the positive and negative terminals (e.g., between A1, and A2 for input No. 1). (They can, however, be short-circuited with the lead wire.)

Terminal Block Diagram

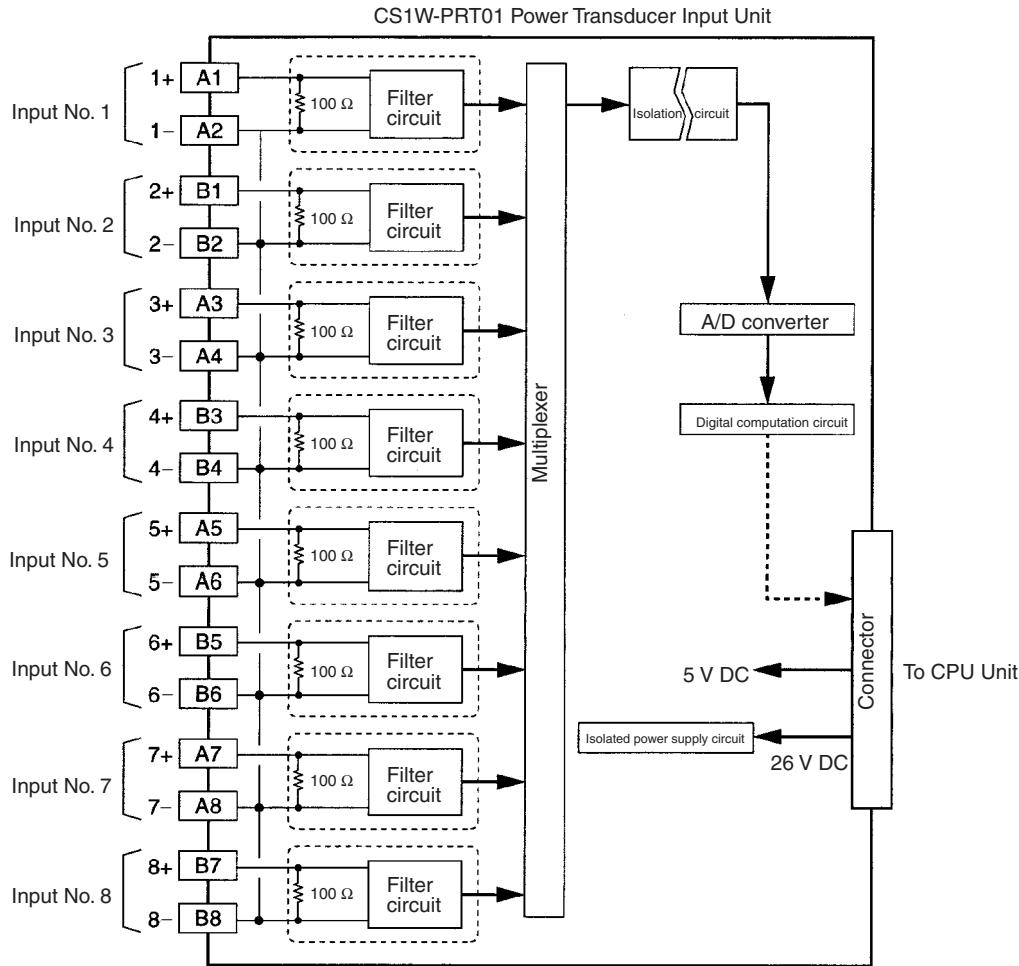

Error Processing

Conversion Data Does Not Change.

| Probable cause | Remedy |
|--|--|
| The gain for span adjustment is set to 0. | Set the gain for span adjustment to a value other than 0. |
| The minimum and maximum values for process value scaling are either the same or are set extremely low. | Set the minimum and maximum values correctly. |
| The input signal type or process value range is set incorrectly. | Check and reset the input signal type and the process value range settings. |
| An input device is malfunctioning, input wiring is faulty, or wiring is disconnected. | Check whether the input voltage or current has changed. Check for faulty or disconnected wiring. |

Values are Not Converted as Intended.

| Probable cause | Remedy |
|--|---|
| The input signal type or process value scaling is set incorrectly. | Check and reset the input signal type and the process value scaling settings. |
| The zero/span adjustment data is incorrect. | Check and correct the zero/span adjustment settings. |
| The inrush input limit function is operating. | Set the inrush input limit function so that it does not operate. |

Converted Values are Unstable.

| Probable cause | Remedy |
|--|---|
| Input signals are being affected by external noise. | Change the connection paths of the input signal lines. (Separate them from sources of noise or use shielded cable.) |
| | Insert 0.01- μ F to 0.1- μ F ceramic capacitors between the positive and negative input terminals. |
| The scaling value is greater than the Unit's resolution. | Reduce the scaling value. |

2-15 CS1W-PTR02 Analog Input Unit (100 mV)

Overview

The CS1W-PTR02 Analog Input Unit provides up to eight inputs of 0 to 100 mV or -100 to 100 mA, and sends the data to the CPU Unit each cycle.

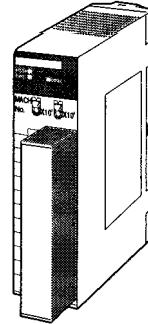

CS1W-PTR02

System Configuration

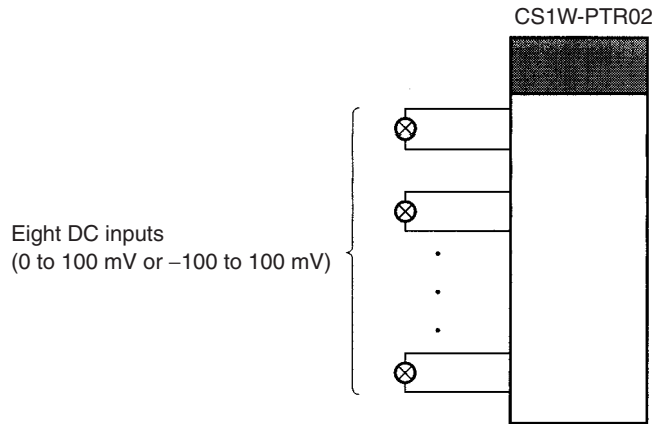

Features

- Up to eight inputs of 0 to 100 mV or -100 to 100 mV can be separately connected.
- Scaling values are sent to the CPU Unit in four digits hexadecimal.
- The inrush input limit function temporarily limits the process value input to a given set value when it increases from a low value (2%), in order to prevent process values from being jumped up by an inrush current when the motor is started up, and so on. (This function is available for inputs of 0 to 100 mV only.)
- Two values for each process value alarm input.
- ON-delay timer for process value alarm.
- Mean value processing (for four values).
- Zero/span adjustment capability during operation.

Model Information

| Unit classification | Model number | Inputs | Input types |
|----------------------------|--------------|--------|---|
| CS-series Special I/O Unit | CS1W-PTR02 | 8 | Either of the following can be selected separately: 0 to 100 mV, or -100 to 100 mV. |

Block Diagram (Order of Processing)

The processing for the eight inputs is as shown in the following diagram.

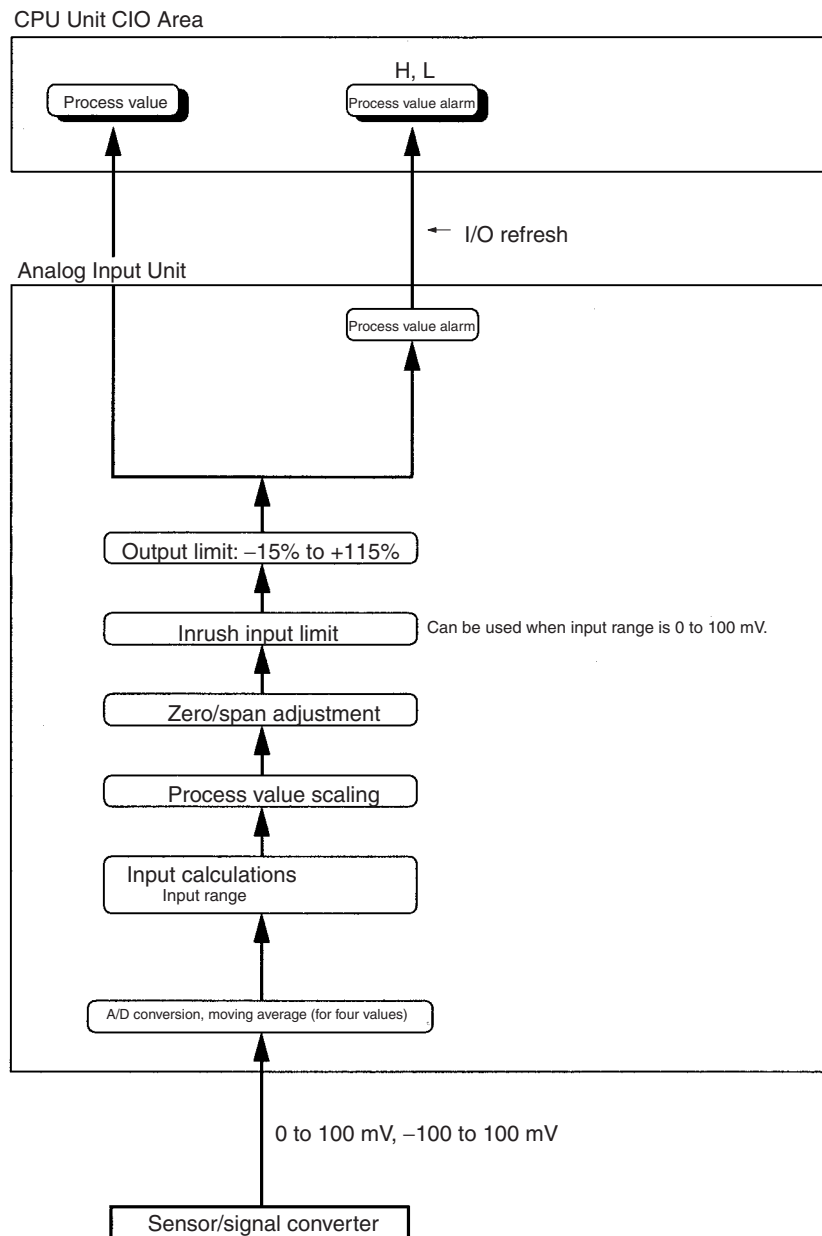

Specifications

| Item | | Specifications |
|--|--|---|
| Model | | CS1W-PTR02 |
| Applicable PLC | | CS Series |
| Unit classification | | CS-series Special I/O Unit |
| Mounting position | | CS-series CPU Rack or CS-series Expansion Rack (Cannot be mounted to C200H Expansion I/O Rack or SYSMAC BUS Remote I/O Slave Rack.) |
| Maximum number of Units | | 80 (within the allowable current consumption and power consumption range) |
| Unit numbers | | 00 to 95 (Cannot duplicate Special I/O Unit numbers.) |
| Areas for data exchange with CPU Unit | Special I/O Unit Area | 10 words/Unit Analog Input Unit to CPU Unit: All process values, process value alarms (L, H) |
| | DM Area words allocated to Special I/O Units | 100 words/Unit CPU Unit to Analog Input Unit: Input signal type, scaling of process value in industrial units, process value alarm setting (L, H), inrush input upper limit, inrush input upper limit time, zero/span adjustment value, etc. |
| Number of inputs | | 8 |
| Input signal type | | Either 0 to 100 mV or -100 to 100 mV. |
| User-defined scaling in industrial units | | Scaling required for the above input signals. (Any minimum and maximum values can be set.) (8 inputs set separately.) |
| Data storage in the CIO Area | | The value derived from carrying out the following processing in order of the process value data is stored in four digits hexadecimal (binary values) in the allocated words in the CIO Area. 1) Mean value processing → 2) Scaling → 3) Zero/span adjustment → 4) Inrush input limit → 5) Output limits |
| | | Input signal type and scaling to industrial units are separate for each of the 8 inputs. Note Input signal type and scaling to industrial units are set in the DM Area. Example: Input signal type: 0 to 100 mV; industrial unit scaling: 0 to 500. DM Area settings are as follows: Input signal type: 0 (0000 hex) Industrial unit maximum value stored: 500 (01F4 hex) Industrial unit minimum value stored: 0 (0000 hex) |
| Accuracy (25°C) | | ±0.2% of full scale |
| Temperature coefficient | | ±0.015%/°C of full scale |
| Resolution | | 1/4,096 of full scale |
| Input signal range | | For 0 to 100 mV: -15 to 115%; for -100 to 100 mV: -7.5 to 107.5% |
| Input impedance | | Balanced: 1 MΩ min. (typical); unbalanced: 20 kΩ (typical) |
| Warmup time | | 10 min |
| Response time | | 1.2 s (travel time from input 0% to 90%, for step input) |
| Conversion period | | 200 ms/8 inputs |
| Maximum time to store data in CPU Unit | | Conversion period + one CPU Unit cycle |
| Input error detection | | None |
| Operation at input disconnection | | Undefined |
| Function | Inrush input limit | When the process value is increased from 2% or less, the inrush input limit function limits the increase for a set time. (It is available only for inputs of 0 to 100 mV.) This function can be used to prevent sudden process value increases due to inrush currents caused by motor startup and so on. Upper limit value: -32,000 to 32,000 Upper limit time: 0 to 100 s |
| | Process value alarm | Process value 2-point alarm (H, L), hysteresis, and ON-delay timer (0 to 60 s) are available. |
| | Mean value processing (input filter) | Calculates the moving average for the past four process values (every 200 ms), and stores that value in the CIO Area as the process value. |
| Isolation | | Between inputs: No isolation Between input terminals and PLC signals: Isolation by transformer and photocoupler. |

| Item | Specifications |
|-------------------------------|---|
| Insulation resistance | 20 MΩ (at 500 V DC) between inputs and internal PLC signals. |
| Dielectric strength | Between inputs and internal PLC signals: 1,000 V AC, at 50/60 Hz, for 1 min, leakage current: 10 mA max. |
| External connections | Terminal block (detachable) |
| Unit number settings | Set by rotary switches on front panel, from 0 to 95. |
| Indicators | Three LED indicators on front panel (for normal operation, errors detected at the Analog Input Unit, and errors related to the CPU Unit). |
| Front panel connector | Sensor input connector terminal block (detachable) |
| Effect on CPU Unit cycle time | 0.3 ms |
| Current consumption | 5 V DC at 150 mA max., 26 V DC at 80 mA max. |
| Dimensions | 35 × 130 × 126 mm (W × H × D) Note The height including the Backplane is 145 mm. |
| Weight | 450 g max. |
| Standard accessories | None |

DM Area Allocations

$$m = D20000 + \text{unit number} \times 100 \text{ (unit number: 0 to 95)}$$

| DM Area address | | | | | | | | Data range | | Default | Data contents |
|--|-------------|-------------|-------------|-------------|-------------|-------------|-------------|-----------------|------------------------------------|-------------------------------------|--|
| Input No. 1 | Input No. 2 | Input No. 3 | Input No. 4 | Input No. 5 | Input No. 6 | Input No. 7 | Input No. 8 | Decimal | Hexadecimal | | |
| m | | | | | | | | 12345, 0 | 3039, 0000 hex | 0000 hex | Default block read command Specifies the direction of data transfer when the PLC is turned ON or the Unit is restarted for DM words m+2 to m+89. <ul style="list-style-type: none"> • 12345 (3039 hex): The data in words m+2 to m+89 is transferred from the Analog Input Unit to the CPU Unit. When the transfer is completed, the value will become 0000 hex. • Other than 12345 (such as 0000 hex): The data in the allocated words of DM Area is transferred from the CPU Unit to the Analog Input Unit. |
| Setting Group 1 (continuously refreshed area): Parameters that are continuously refreshed during PLC operation (regardless of the CPU Unit's operation mode) | | | | | | | | | | | |
| | | | | | | | | | | Process value alarm settings | |
| m + 2 | m + 6 | m + 10 | m + 14 | m + 18 | m + 22 | m + 26 | m + 30 | -32768 to 32767 | 8000 to FFFF hex, 0000 to 7FFF hex | 4000 (0FA0 hex) | Process value H (high limit) alarm setting (Set at process value scaling value.) |
| m + 3 | m + 7 | m + 11 | m + 15 | m + 19 | m + 23 | m + 27 | m + 31 | -32768 to 32767 | 8000 to FFFF hex, 0000 to 7FFF hex | 0 (0000 hex) | Process value L (low limit) alarm setting (Set at process value scaling value.) |
| Zero/span adjustment | | | | | | | | | | | |
| m + 4 | m + 8 | m + 12 | m + 16 | m + 20 | m + 24 | m + 28 | m + 32 | 0 to 32000 | 0000 to 7D00 hex | 10000 (2710 hex) | Gain for span adjustment (set value x 0.0001) |
| m + 5 | m + 9 | m + 13 | m + 17 | m + 21 | m + 25 | m + 29 | m + 33 | -32000 to 32000 | 8300 to FFFF hex, 0000 to 7D00 hex | 0 (0000 hex) | Zero adjustment value (Set at process value scaling value.) |
| Setting Group 2 (initial settings area): Parameters that are transferred one time from the CPU Unit to the Analog Input Unit if word m contains other than 12345 when the PLC is turned ON or the Analog Input Unit is restarted. | | | | | | | | | | | |
| m + 34 | m + 41 | m + 48 | m + 55 | m + 62 | m + 69 | m + 76 | m + 83 | 0, 1 | 0000 to 0001 hex | 0 (0000 hex) | Input signal type 0: 0 to 100 mV 1: -100 to 100 mV |

| DM Area address | | | | | | | | Data range | | Default | Data contents |
|--------------------------------------|-------------|-------------|-------------|-------------|-------------|-------------|-------------|-----------------|------------------------------------|-----------------|--|
| Input No. 1 | Input No. 2 | Input No. 3 | Input No. 4 | Input No. 5 | Input No. 6 | Input No. 7 | Input No. 8 | Decimal | Hexadecimal | | |
| Process value scaling | | | | | | | | | | | |
| m + 35 | m + 42 | m + 49 | m + 56 | m + 63 | m + 70 | m + 77 | m + 84 | -32000 to 32000 | 8300 to FFFF hex, 0000 to 7D00 hex | 4000 (0FA0 hex) | Value stored for maximum value in range (span) |
| m + 36 | m + 43 | m + 50 | m + 57 | m + 64 | m + 71 | m + 78 | m + 85 | -32000 to 32000 | 8300 to FFFF hex, 0000 to 7D00 hex | 0 (0000 hex) | Value stored for minimum value in range (zero) |
| Alarm supplementary functions | | | | | | | | | | | |
| m + 37 | m + 44 | m + 51 | m + 58 | m + 65 | m + 72 | m + 79 | m + 86 | 0 to 32000 | 0000 to 7D00 hex | 40 (0028 hex) | Alarm hysteresis (Set at process value scaling value.) |
| m + 38 | m + 45 | m + 52 | m + 59 | m + 66 | m + 73 | m + 80 | m + 87 | 0 to 60 | 0000 to 003C hex | 0 (0000 hex) | Alarm ON-delay time (Unit: s) |
| Inrush input limit function | | | | | | | | | | | |
| m + 39 | m + 46 | m + 53 | m + 60 | m + 67 | m + 74 | m + 81 | m + 88 | 0 to 100 | 0000 to 0064 hex | 0 (0000 hex) | Inrush upper limit time (Unit: s) 0: No limit |
| m + 40 | m + 47 | m + 54 | m + 61 | m + 68 | m + 75 | m + 82 | m + 89 | -32000 to 32000 | 8300 to FFFF hex, 0000 to 7D00 hex | 4000 (0FA0 hex) | Inrush upper limit value |
| Storage parameter | | | | | | | | | | | |
| m + 90 | m + 91 | m + 92 | m + 93 | m + 94 | m + 95 | m + 96 | m + 97 | 0 to 89 | 0000 to 0059 hex | 0 (0000 hex) | Address of Data Range Error (See note.) |

Note The ERC indicator on the Unit's front panel will light if an out-of-range setting is made in either Setting Group 1 or 2. The offset from word m to the first word containing the out-of-range error will be stored as the Address of Data Range Error in the DM Area in four digits hexadecimal. For more information, refer to 1-6 Error Processing.

CIO Area Allocations

n = 2000 + unit number × 10 (unit number: 0 to 95)

| Direction | Word | Bit | Name | | Data range | Contents |
|-------------------------------|------|-----|-------------|------------------------------------|------------|--|
| Analog Input Unit to CPU Unit | n | 00 | Input No. 1 | Process value L (low limit) alarm | 0, 1 | 0: Process value > Set value 1: Process value ≤ Set value |
| | | 01 | | Process value H (high limit) alarm | 0, 1 | 0: Process value < Set value 1: Process value ≥ Set value |
| | | 02 | Input No. 2 | Process value L (low limit) alarm | 0, 1 | Same as for input No. 1. |
| | | 03 | | Process value H (high limit) alarm | 0, 1 | |
| | | 04 | Input No. 3 | Process value L (low limit) alarm | 0, 1 | Same as for input No. 1. |
| | | 05 | | Process value H (high limit) alarm | 0, 1 | |
| | | 06 | Input No. 4 | Process value L (low limit) alarm | 0, 1 | Same as for input No. 1. |
| | | 07 | | Process value H (high limit) alarm | 0, 1 | |
| | | 08 | Input No. 5 | Process value L (low limit) alarm | 0, 1 | Same as for input No. 1. |
| | | 09 | | Process value H (high limit) alarm | 0, 1 | |
| | | 10 | Input No. 6 | Process value L (low limit) alarm | 0, 1 | Same as for input No. 1. |
| | | 11 | | Process value H (high limit) alarm | 0, 1 | |
| | | 12 | Input No. 7 | Process value L (low limit) alarm | 0, 1 | Same as for input No. 1. |
| | | 13 | | Process value H (high limit) alarm | 0, 1 | |
| | | 14 | Input No. 8 | Process value L (low limit) alarm | 0, 1 | Same as for input No. 1. |
| | | 15 | | Process value H (high limit) alarm | 0, 1 | |

| Direction | Word | Bit | Name | Data range | Contents |
|-------------------------------|-------|----------|---------------------------|---|---|
| Analog Input Unit to CPU Unit | n + 1 | 00 to 15 | Input No. 1 process value | -32768 to 32767 (8000 to FFFF hex, 0000 to 7FFF hex) | The present process value is stored according to the scaling set in the allocated words of the DM Area. |
| | n + 2 | 00 to 15 | Input No. 2 process value | -32768 to 32767 (8000 to FFFF hex, 0000 to 7FFF hex) | |
| | n + 3 | 00 to 15 | Input No. 3 process value | -32768 to 32767 (8000 to FFFF hex, 0000 to 7FFF hex) | |
| | n + 4 | 00 to 15 | Input No. 4 process value | -32768 to 32767 (8000 to FFFF hex, 0000 to 7FFF hex) | |
| | n + 5 | 00 to 15 | Input No. 5 process value | -32768 to 32767 (8000 to FFFF hex, 0000 to 7FFF hex) | |
| | n + 6 | 00 to 15 | Input No. 6 process value | -32768 to 32767 (8000 to FFFF hex, 0000 to 7FFF hex) | |
| | n + 7 | 00 to 15 | Input No. 7 process value | -32768 to 32767 (8000 to FFFF hex, 0000 to 7FFF hex) | |
| | n + 8 | 00 to 15 | Input No. 8 process value | -32768 to 32767 (8000 to FFFF hex, 0000 to 7FFF hex) | |

Terminal Connection Diagram

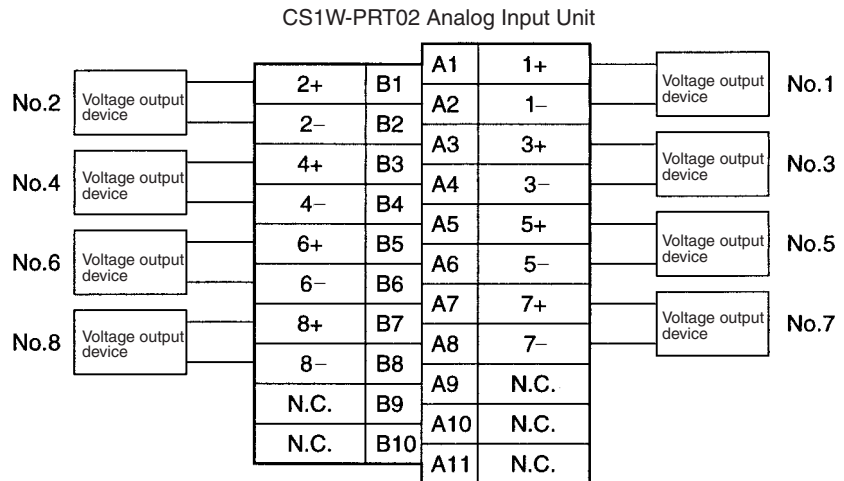

Note Short-circuit all unused inputs between the positive and negative terminals (e.g., between A1, and A2 for input No. 1) with the lead wire.

Terminal Block Diagram

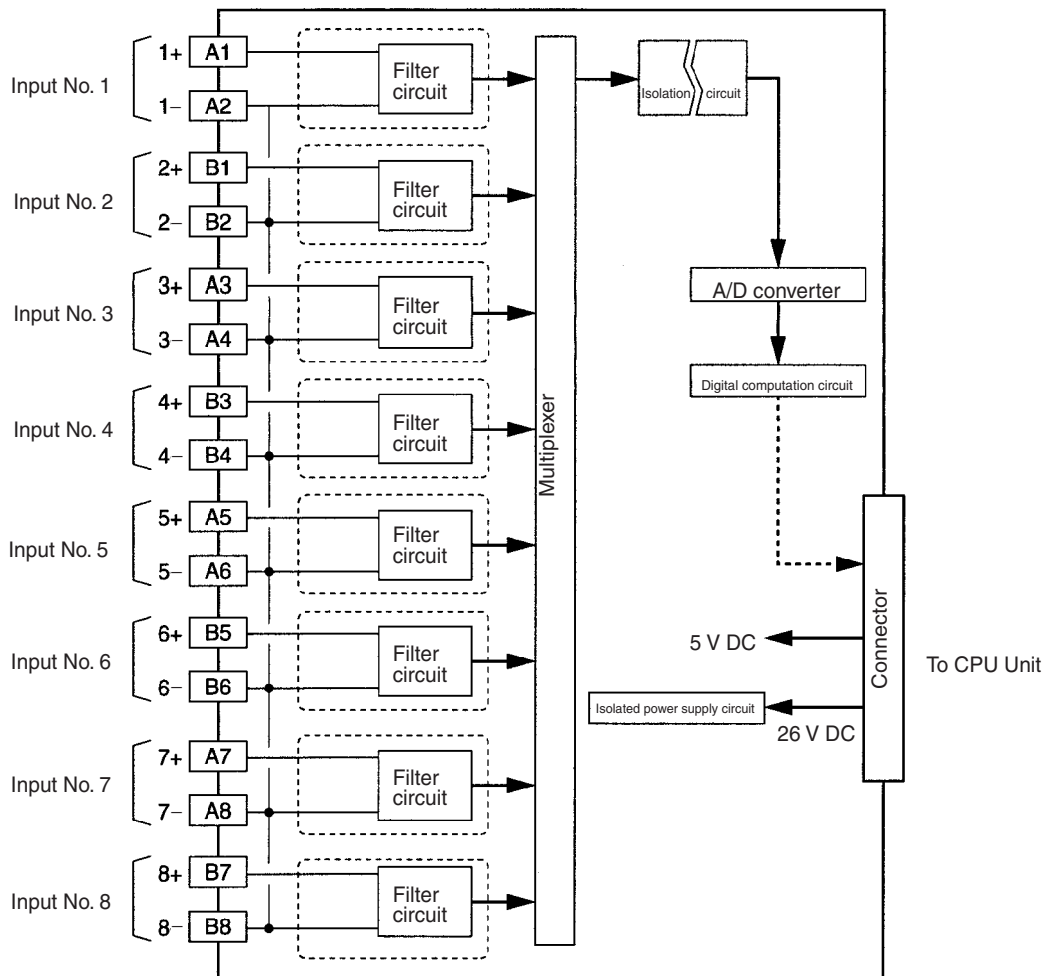

Error Processing

Conversion Data Does Not Change.

| Probable cause | Remedy |
|--|--|
| The gain for span adjustment is set to 0. | Set the gain for span adjustment to a value other than 0. |
| The minimum and maximum values for process value scaling are either the same or are set extremely low. | Set the minimum and maximum values correctly. |
| The input signal type or process value range is set incorrectly. | Check and reset the input signal type and the process value range settings. |
| An input device is malfunctioning, input wiring is faulty, or wiring is disconnected. | Check whether the input voltage or current has changed. Check for faulty or disconnected wiring. |

Values are Not Converted as Intended.

| Probable cause | Remedy |
|--|---|
| The input signal type or process value scaling is set incorrectly. | Check and reset the input signal type and the process value scaling settings. |
| The zero/span adjustment data is incorrect. | Check and correct the zero/span adjustment settings. |
| The inrush input limit function is operating. | Set the inrush input limit function so that it does not operate. |

Converted Values are Unstable.

| Probable cause | Remedy |
|--|---|
| Input signals are being affected by external noise. | Change the connection paths of the input signal lines. (Separate them from sources of noise or use shielded cable.) |
| | Insert 0.01- μ F to 0.1- μ F ceramic capacitors between the positive and negative input terminals. |
| The scaling value is greater than the Unit's resolution. | Reduce the scaling value. |

2-16 CS1W-PPS01 Isolated-type Pulse Input Unit

Overview

The CS1W-PPS01 Isolated-type Pulse Input Unit provides up to four pulses from a device such as a displacement flowmeter, and sends scaled instantaneous values (pulses/time unit) to the CPU Unit each cycle. The accumulated value can also be calculated at the same time and transferred to the CPU Unit at each cycle.

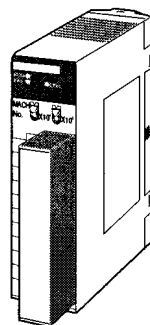

CS1W-PPS01

System Configuration

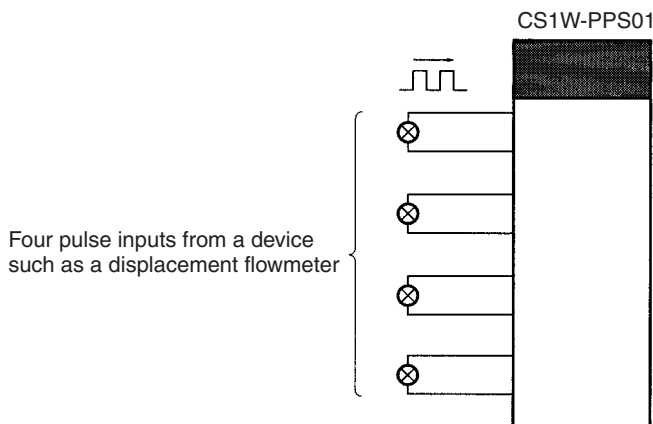

Features

- Up to four pulse inputs can be connected per Unit.
- Instantaneous values (pulses × pulse weight/time unit) are scaled and sent to the CPU Unit in four digits hexadecimal.
- Four values for each instantaneous value alarm input
- ON-delay timer for instantaneous value alarm
- Mean value processing
- Zero/span adjustment capability during operation
- Accumulated value output

Model Information

| Unit classification | Model number | Inputs | Input types |
|----------------------------|--------------|--------|--|
| CS-series Special I/O Unit | CS1W-PPS01 | 4 | Pulse inputs of 0 to 20,000 pulses/s or 0 to 20 pulses/s |

Block Diagram (Order of Processing)

The processing for the four inputs is as shown in the following diagram.

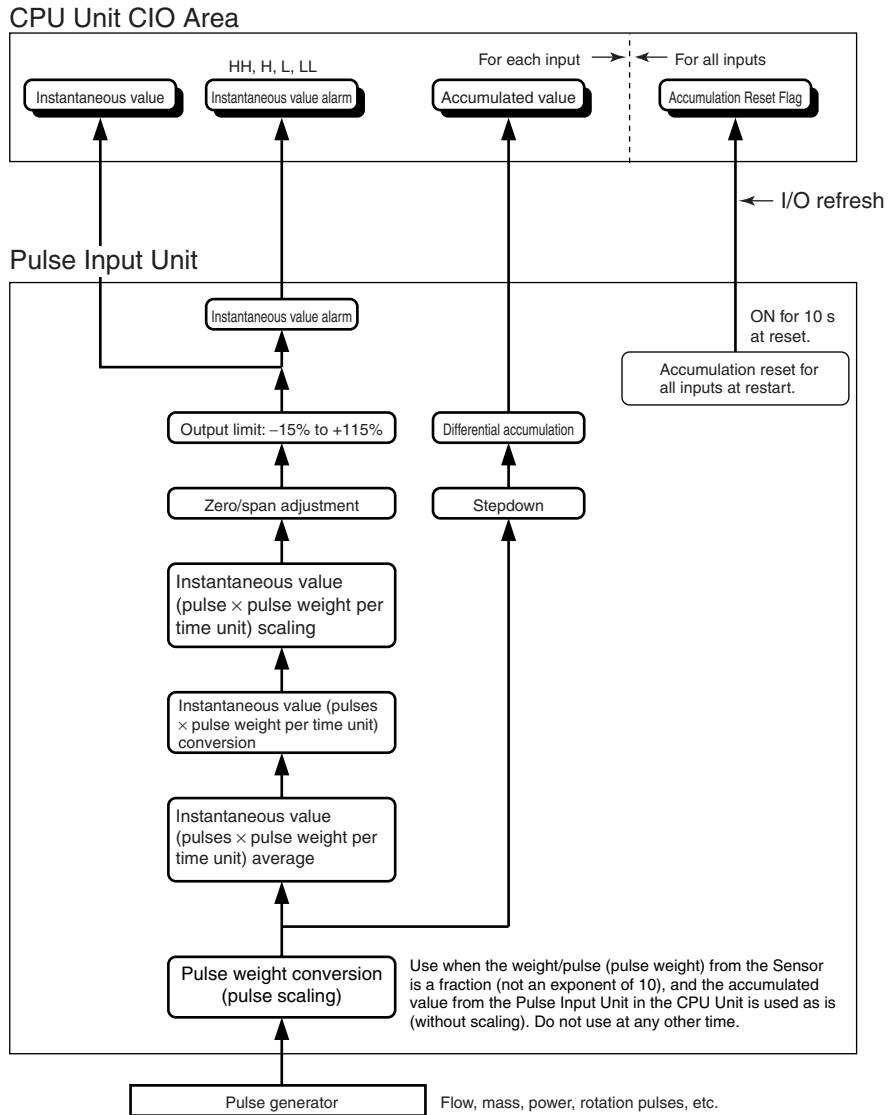

Specifications

| Item | | Specifications |
|--|--|--|
| Model | | CS1W-PPS01 |
| Applicable PLC | | CS-series |
| Unit classification | | CS-series Special I/O Unit |
| Mounting position | | CS-series CPU Rack or CS-series Expansion Rack (Cannot be mounted to C200H Expansion I/O Rack or SYSMAC BUS Remote I/O Slave Rack.) |
| Maximum number of Units | | 80 (within the allowable current consumption and power consumption range) |
| Unit numbers | | 00 to 95 (Cannot duplicate Special I/O Unit numbers.) |
| Areas for data exchange with CPU Unit | Special I/O Unit Area | 10 words/Unit Pulse Input Unit to CPU Unit: All process values, process value alarms (LL, L, H, HH), accumulated values, Accumulation Reset Bit |
| | DM Area words allocated to Special I/O Units | 100 words/Unit CPU Unit to Pulse Input Unit: Instantaneous value conversion coefficient, instantaneous value scaling, pulse weight, number of values for moving average, instantaneous value alarm settings (LL, L, H, HH), zero/span adjustment, etc. |
| Number of pulse inputs | | 4 |
| Pulse input type | | <p>Voltage input, no-voltage semiconductor input, contact input (selected individually for each of 4 inputs, according to connection terminals)</p> <p>No-voltage semiconductor input: Connected to voltage input terminals (between Fn+ and COMn). Maximum coefficient speed: 20,000 pulses/s (duty ratio: 50%) Detection voltage: 4 V DC Short-circuit current between terminals: 1.2 mA DC ON resistance: 0.8 kΩ max. OFF resistance: 5.0 kΩ min.</p> <p>Voltage input: Connected to voltage input terminals (between Fn+ and COMn). Waveform: Square wave Maximum coefficient speed: 20,000 pulses/s (duty ratio: 50%) ON voltage: 0 to 1 V OFF voltage: 3 to 30 V</p> <p>Contact input: Connected to contact input terminals (between Sn+ and COMn). Maximum coefficient speed: 20 pulses/s (duty ratio: 50%) Detection voltage: 8 V DC Short-circuit current between terminals: 2.4 mA DC ON resistance: 0.8 kΩ max. OFF resistance: 5.0 kΩ min.</p> |
| Sensor power supply | | <p>For no-voltage semiconductor inputs, etc., a 12-V DC power supply can be provided for the sensors that are the pulse sources.</p> <p>Output voltage: 12 V DC ±15% Current capacity: 30 mA max. Limit current when short-circuited: 31 to 55 mA Allowable short-circuit time: No limit</p> |
| Accumulation conversion period | | 100 ms/4 inputs |
| Maximum time to store data in CPU Unit | | Conversion period + one CPU Unit cycle |

| Item | | Specifications | |
|----------|--------------------------------------|---|--|
| Function | Instantaneous value output | Conversion to instantaneous values | <p>This function can be used to count the number of pulses per time unit, and to convert the values to instantaneous values (pulses x pulse weight / time unit). Any of the following can be selected as the time unit: 1 s, 3 s, 10 s, 30 s, or 60 s. (The time unit is set in the DM Area.)</p> <p>Note 1 Errors and fluctuations will increase when the input signal pulse rate is low, so specify a longer time unit.</p> <p>Note 2 The instantaneous value is only refreshed at intervals of the time unit set. Therefore, when the Unit is restarted, the instantaneous value will be 0000 until the time set as the time unit has elapsed.</p> <p>Note 3 When pulse weight conversion is used for accumulated values, the number of pulses obtained by multiplying the actual number of input pulses by the pulse weight (0.1000 to 3.2000) for one time unit is used.</p> |
| | Instantaneous value scaling | <p>This function can be used for scaling instantaneous values (pulses x pulse weight/time unit), i.e., setting data with respect to a maximum value, and storing them in the allocated words of the CIO Area.</p> <ul style="list-style-type: none"> When instantaneous value (pulses x pulse weight/time unit) is 100% input: Can be set from 0.001 pulses/time unit to 32,000 pulses/time unit. Maximum value for Instantaneous value scaling (industrial units): Scaling of the above instantaneous value (100% input) is possible from -32,000 to 32,000 (8300 to FFFF, 0000 to 7D00 hex). <p>Note When pulse weight conversion is used for accumulated values, scaling is already performed for each pulse, so an exponent of 10 of the industrial unit is set in the instantaneous value (pulses x pulse weight per time unit) for a 100% input.</p> | <p>Example 1: To obtain a pulse input of 0 to 2,000 pulses/s for a flow of 0 to 300.0 ml/s: Time unit: 1 s Instantaneous value 100% input: 2,000 Maximum value for instantaneous value scaling (industrial units): 3,000</p> <p>Example 2: When pulse inputs at 0 to 2,000 pulses/s are obtained for a flowrate of 0 to 300.0 ml/s, and the pulse weight function is used for totaling: There are 0.15 ml per pulse, so the pulse weight = 0.15. For a flowrate of 0 to 300.0 ml/s, 0 to 2,000 x 0.15 = 300 pulses/s. Therefore, Time unit: 1 s Instantaneous value 100% input: 300 Maximum value for instantaneous value scaling (industrial units): 3,000</p> |
| | Data storage in the CIO Area | <p>The value derived from carrying out the following processing in order of the instantaneous value (pulses x pulse weight/time unit) is stored in four digits hexadecimal (binary values) in the allocated words in the CIO Area.</p> <p>1) Mean value processing → 2) Instantaneous value scaling → 3) Scaling → 4) Zero/span adjustment → 5) Output limits</p> | |
| | Mean value processing (input filter) | <p>Calculates the moving average for the specified number of past instantaneous values (1 to 16), and stores that value in the CIO Area as the instantaneous value.</p> | |
| | Instantaneous value alarm | <p>Instantaneous value 4-point alarm (HH, H, L, LL), hysteresis, and ON-delay timer (0 to 60 s) are available.</p> | |

| Item | | Specifications | |
|-------------------------------|--------------------|--|--|
| Function | Accumulated output | Pulse weight conversion | <p>Performs scaling for a single pulse.</p> <p>Use for the accumulated value when the pulse weight (weight/pulse) is a fraction (not an exponent of 10). (See note.)</p> <p>The pulse weight (0.1 to 3.2) is multiplied by the actual number of pulses input. This number of pulses is used as the input for conversion to instantaneous values (pulses x pulse weight per time unit) and the input for totaling prior to stepdown.</p> <p>Example: When the pulse weight from the flowmeter is 0.26 ml/pulse, the pulse weight is set to 0.26. When one pulse (0.26 ml) is input, it is treated as a 0.26 pulse, and when two pulses (0.52 ml) are input, they are treated as a 0.52 pulse.</p> <p>The weight per pulse becomes 1 ml, so to calculate in the CPU Unit the simple (unscaled) value in industrial units (ml) based on the accumulated value from the Pulse Input Unit (value in words n+5 to n+8), the value can be calculated simply using 1 ml/pulse.</p> <p>Note When the accumulated value from the Pulse Input Unit in the CPU Unit is not used (i.e., when only the instantaneous value is used), pulse weight conversion is not required. Use instantaneousness value scaling to convert to industrial units.</p> |
| | | Accumulated value | <p>The accumulated number of pulses (0 to 9,999 pulses) for each input is stored in the allocated words of the CIO Area. When 9,999 is exceeded, the value returns to 0 and starts counting again.</p> <p>Note When pulse weight conversion is used, the accumulated value for the number of pulses obtained by multiplying the actual number of input pulses by the pulse weight (0.1000 to 3.2000) is used.</p> |
| | | Stepdown | <p>When the accumulated value is used, this function prevents accumulated value overflow by reducing the number of input pulses. The actual number of input pulses is multiplied by one of four factors (x1, x0.1, x0.01, or x0.001), and the number of input pulses accumulated is then based on that value.</p> <p>Note This stepdown function operates only for accumulated values, and not for instantaneous values. When the pulse weight conversion function is used, it uses for the number of pulses obtained by multiplying the actual number of input pulses by the pulse weight (0.1000 to 3.2000).</p> |
| Isolation | | Between inputs and between input terminals and PLC signals: Isolation by transformer and photocoupler | |
| Insulation resistance | | 20 MΩ (at 500 V DC) between inputs | |
| Dielectric strength | | Between inputs: 1,000 V AC, at 50/60 Hz, for 1 min, leakage current 10 mA max. | |
| External connections | | Terminal block (detachable) | |
| Unit number settings | | Set by rotary switches on front panel, from 0 to 95. | |
| Indicators | | Three LED indicators on front panel (for normal operation, errors detected at the Pulse Input Unit, and errors related to the CPU Unit). | |
| Front panel connector | | Sensor input connector terminal block (detachable) | |
| Effect on CPU Unit cycle time | | 0.3 ms | |
| Current consumption | | 5 V DC at 200 mA max., 26 V DC at 160 mA max. | |
| Warmup time | | 10 min | |
| Dimensions | | 35 × 130 × 126 mm (W × H × D) Note The height including the Backplane is 145 mm. | |
| Weight | | 450 g max. | |
| Standard accessories | | None | |

DM Area Allocations

m = D20000 + unit number × 100 (unit number: 0 to 95)

| Input No. 1 | Input No. 2 | Input No. 3 | Input No. 4 | Decimal | Hexadecimal | Default | Data contents |
|--|-------------|-------------|-------------|-----------------|------------------------------------|------------------|--|
| m | | | | 12345, 0 | 3039, 0000 hex | 0000 hex | Default block read command Specifies the direction of data transfer when the PLC is turned ON or the Unit is restarted for DM words m+2 to m+57. <ul style="list-style-type: none"> 12345 (3039 hex): The data in words m+2 to m+57 is transferred from the Pulse Input Unit to the CPU Unit. When the transfer is completed, the value will become 0000 hex. Other than 12345 (3039 hex) (such as 0000 hex): The data in the allocated words of DM Area is transferred from the CPU Unit to the Pulse Input Unit. |
| Setting Group 1 (continuously refreshed area): Parameters that are continuously refreshed during PLC operation (regardless of the CPU Unit's operation mode) | | | | | | | |
| | | | | | | | Instantaneous value alarm settings |
| m + 2 | m + 8 | m + 14 | m + 20 | -32768 to 32767 | 8000 to FFFF hex, 0000 to 7FFF hex | 4200 (1068 hex) | Instantaneous value HH (high high limit) alarm setting (Set at instantaneous value scaling value.) |
| m + 3 | m + 9 | m + 15 | m + 21 | -32768 to 32767 | 8000 to FFFF hex, 0000 to 7FFF hex | 4000 (0FA0 hex) | Instantaneous value H (high limit) alarm setting (Set at instantaneous value scaling value.) |
| m + 4 | m + 10 | m + 16 | m + 22 | -32768 to 32767 | 8000 to FFFF hex, 0000 to 7FFF hex | 0 (0000 hex) | Instantaneous value L (low limit) alarm setting (Set at instantaneous value scaling value.) |
| m + 5 | m + 11 | m + 17 | m + 23 | -32768 to 32767 | 8000 to FFFF hex, 0000 to 7FFF hex | -200 (FF38 hex) | Instantaneous value LL (low low limit) alarm setting (Set at instantaneous value scaling value.) |
| | | | | | | | Zero/span adjustment |
| m + 6 | m + 12 | m + 18 | m + 24 | 0 to 32000 | 0000 to 7D00 hex | 10000 (2710 hex) | Gain for span adjustment (Set value x 0.0001) |
| m + 7 | m + 13 | m + 19 | m + 25 | -32000 to 32000 | 8300 to FFFF hex, 0000 to 7D00 hex | 0 (0000 hex) | Zero adjustment value (Set at instantaneous value scaling value.) |
| Setting Group 2 (initial settings area): Parameters that are transferred one time from the CPU Unit to the Pulse Input Unit if word m contains other than 12345 when the PLC is turned ON or the Pulse Input Unit is restarted. | | | | | | | |
| m + 26 | m + 34 | m + 42 | m + 50 | 1000 to 32000 | 03E8 to 7D00 hex | 10000 (2710 hex) | Pulse weight Set value x 0.0001 (0.1 to 3.2) The result of multiplying the actual number of pulses input by the value set here is input as the instantaneous value (pulses x pulse weight per time unit) for conversion and the input for totaling prior to stepdown. |
| m + 27 | m + 35 | m + 43 | m + 51 | 0 to 3 | 0000 to 0003 hex | 0 (0000 hex) | Accumulated value stepdown 0: x1; 1: x0.1; 2: x0.01; 3: x0.001 The product of multiplying the actual number of pulses input x the pulse weight x the stepdown ratio set here is input as the accumulated value. |
| m + 28 | m + 36 | m + 44 | m + 52 | 1 to 16 | 0001 to 0010 hex | 1 (0001 hex) | Number of process values for calculating moving average for mean value processing |
| | | | | | | | Instantaneous value conversion function |
| m + 29 | m + 37 | m + 45 | m + 53 | 0 to 32000 | 0000 to 7D00 hex | 1000 (03E8 hex) | Instantaneous value when 100% input Note When pulse weight conversion is used, the value set here is the number of pulses x pulse weight per time unit. |
| m + 30 | m + 38 | m + 46 | m + 54 | --- | Bit 00 to 03: 0 to 3 hex | 0 (0 hex) | Decimal point position (from right) for instantaneous value when 100% input |
| | | | | --- | Bit 04 to 07: 0 to 4 hex | 0 (0 hex) | Instantaneous value time unit (matching conversion period) 0: 1 s; 1: 3 s; 2: 10 s; 3: 30 s; 4: 60 s |
| | | | | --- | Bit 08 to 15: 00 hex | 00 hex | Not used. |
| m + 31 | m + 39 | m + 47 | m + 55 | -32000 to 32000 | 8300 to FFFF hex, 0000 to 7D00 hex | 4000 (0FA0 hex) | Maximum instantaneous value scaling value Data stored in allocated words of CIO Area when instantaneous value is 100% input as above |
| | | | | | | | Alarm supplementary functions |
| m + 32 | m + 40 | m + 48 | m + 56 | 0 to 32000 | 0000 to 7D00 hex | 40 (0028 hex) | Alarm hysteresis (Set at instantaneous value scaling value.) |

| Input No. 1 | Input No. 2 | Input No. 3 | Input No. 4 | Decimal | Hexadecimal | Default | Data contents |
|--------------------------|-------------|-------------|-------------|---------|------------------|-----------------|---|
| m + 33 | m + 41 | m + 49 | m + 57 | 0 to 60 | 0000 to 003C hex | 0 (0000 hex) | Alarm ON-delay time (Unit: s) |
| Storage parameter | | | | | | | |
| m + 58 | m + 59 | m + 60 | m + 61 | 0 to 57 | 0000 to 0039 hex | 0 (0000 hex) | Address of Data Range Error (See note.) |

Note The ERC indicator on the Unit's front panel will light if an out-of-range setting is made in either Setting Group 1 or 2. The offset from word m to the first word containing the out-of-range error will be stored as the Address of Data Range Error in the DM Area in four digits hexadecimal. For more information, refer to 1-6 Error Processing.

CIO Area Allocations

$$n = 2000 + \text{unit number} \times 10 \text{ (unit number: 0 to 95)}$$

| Direction | Word | Bit | Name | | Data range | Contents |
|------------------------------|------|-----|-------------|--|------------|--|
| Pulse Input Unit to CPU Unit | n | 00 | Input No. 1 | Instantaneous value LL (low low limit) alarm | 0, 1 | 0: Instantaneous value > Set value 1: Instantaneous value ≤ Set value |
| | | 01 | | Instantaneous value L (low limit) alarm | 0, 1 | |
| | | 02 | | Instantaneous value H (high limit) alarm | 0, 1 | 0: Instantaneous value < Set value 1: Instantaneous value ≥ Set value |
| | | 03 | | Instantaneous value HH (high high limit) alarm | 0, 1 | |
| | | 04 | Input No. 2 | Instantaneous value LL (low low limit) alarm | 0, 1 | Same as for input No. 1. |
| | | 05 | | Instantaneous value L (low limit) alarm | 0, 1 | |
| | | 06 | | Instantaneous value H (high limit) alarm | 0, 1 | |
| | | 07 | | Instantaneous value HH (high high limit) alarm | 0, 1 | |
| | | 08 | Input No. 3 | Instantaneous value LL (low low limit) alarm | 0, 1 | Same as for input No. 1. |
| | | 09 | | Instantaneous value L (low limit) alarm | 0, 1 | |
| | | 10 | | Instantaneous value H (high limit) alarm | 0, 1 | |
| | | 11 | | Instantaneous value HH (high high limit) alarm | 0, 1 | |
| | | 12 | Input No. 4 | Instantaneous value LL (low low limit) alarm | 0, 1 | Same as for input No. 1. |
| | | 13 | | Instantaneous value L (low limit) alarm | 0, 1 | |
| | | 14 | | Instantaneous value H (high limit) alarm | 0, 1 | |
| | | 15 | | Instantaneous value HH (high high limit) alarm | 0, 1 | |

| Direction | Word | Bit | Name | Data range | Contents |
|------------------------------|-------|----------|---------------------------------|--|---|
| Pulse Input Unit to CPU Unit | n + 1 | 00 to 15 | Input No. 1 instantaneous value | -32768 to 32767 (8000 to FFFF hex, 0000 to 7FFF hex) | The present instantaneous value is stored according to the scaling set in the allocated words of the DM Area. |
| | n + 2 | 00 to 15 | Input No. 2 instantaneous value | -32768 to 32767 (8000 to FFFF hex, 0000 to 7FFF hex) | |
| | n + 3 | 00 to 15 | Input No. 3 instantaneous value | -32768 to 32767 (8000 to FFFF hex, 0000 to 7FFF hex) | |
| | n + 4 | 00 to 15 | Input No. 4 instantaneous value | -32768 to 32767 (8000 to FFFF hex, 0000 to 7FFF hex) | |
| | n + 5 | 00 to 15 | Input No. 1 accumulated value | 0 to 9999 (0000 to 270F hex) | The accumulated value for the number of pulses (after step-down) is stored here. |
| | n + 6 | 00 to 15 | Input No. 2 accumulated value | 0 to 9999 (0000 to 270F hex) | |
| | n + 7 | 00 to 15 | Input No. 3 accumulated value | 0 to 9999 (0000 to 270F hex) | |
| | n + 8 | 00 to 15 | Input No. 4 accumulated value | 0 to 9999 (0000 to 270F hex) | |
| | n + 9 | 00 | Accumulation Reset Bit | 0, 1 | When the accumulated value is reset, this flag turns ON for 10 s. (See note.) |

Note The accumulated value is reset when the PLC is turned ON or when the Pulse Input Unit is restarted.

Terminal Connection Diagram

No-voltage Semiconductor Input

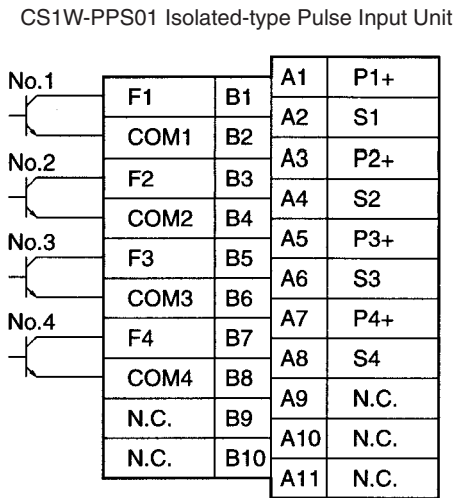

Voltage Input

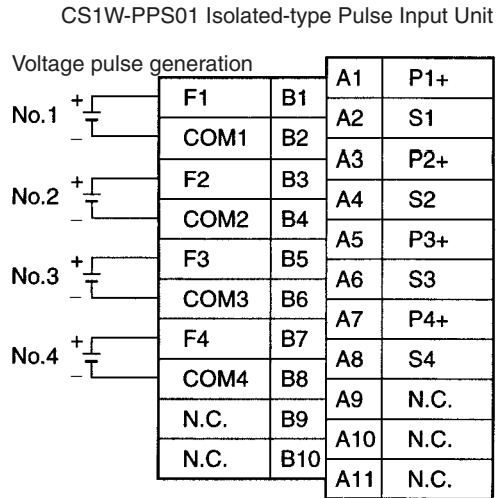

Contact Input

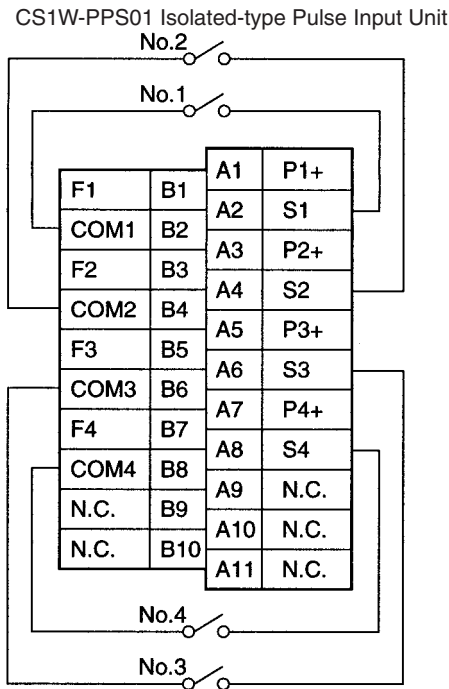

3-wire Sensor Input

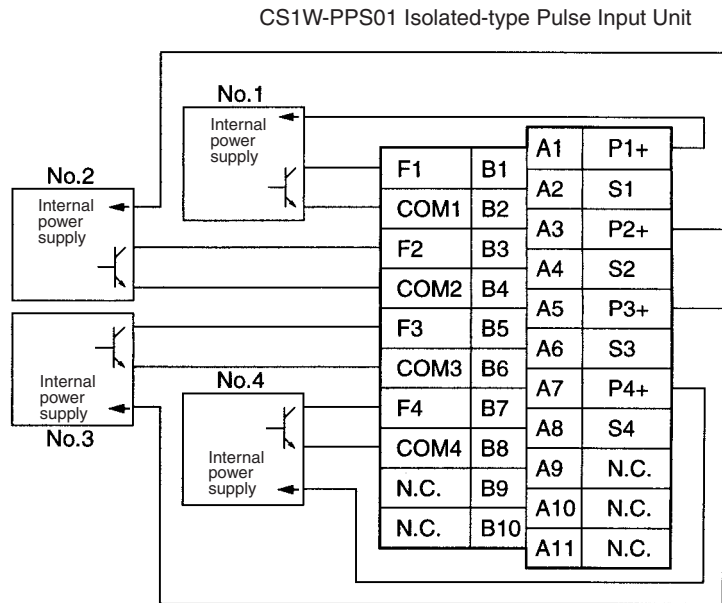

Note In all of the above cases, leave all unused inputs open between the terminals (e.g., between B1 and B2 for no-voltage semiconductor input No. 1).

Terminal Block Diagram

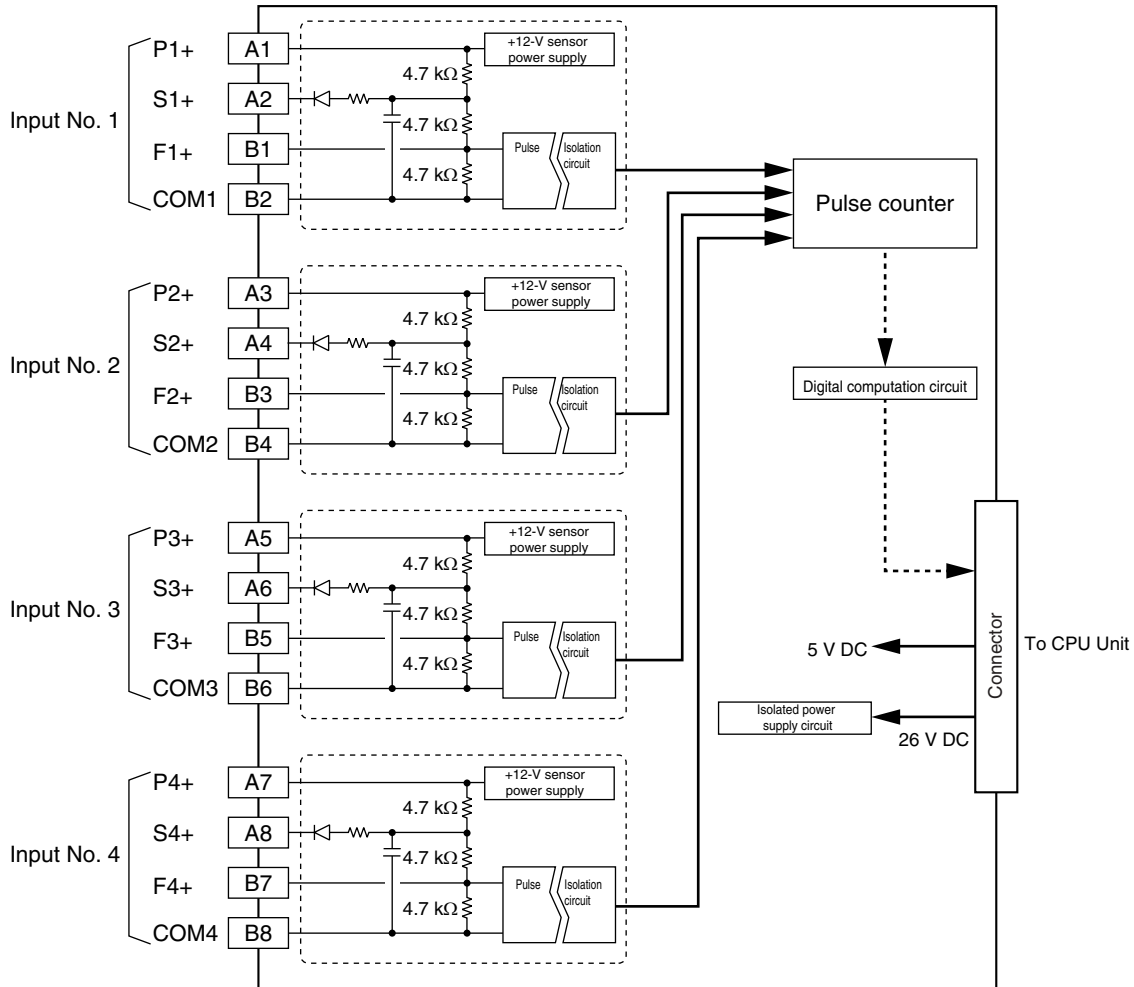

Contact Input (for Metal Contacts) Voltage Pulse Input

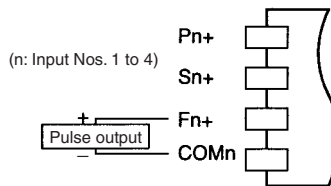
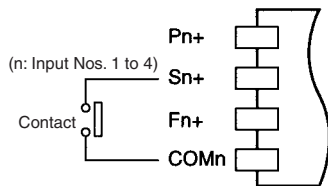

Sensor Power Supply (Connected to 3-wire Sensor)

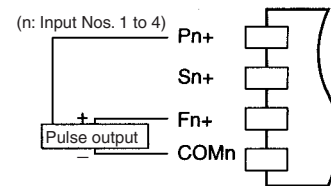

Error Processing

Accumulated Values Do Not Change.

| Probable cause | Remedy |
|---|--|
| An input device is malfunctioning, input wiring is faulty, or wiring is disconnected. | Check whether the input voltage has changed to exceed the minimum OFF voltage or the maximum ON voltage. |
| | Check for faulty or disconnected wiring. |

Accumulation Data is Different from the Number of Pulses Input.

| Probable cause | Remedy |
|---|---|
| Input signals are being affected by external noise. | Change the connection paths of the input signal lines. (Separate them from sources of noise or use shielded cable.) |
| | Insert 0.01- μ F to 0.1- μ F ceramic capacitors between the positive and negative input terminals. |
| The pulse weight or accumulation stepdown settings are incorrect. | Check the pulse weight and accumulation stepdown settings. |
| Pulses exceeding the allowable frequency are being input. | Check the input signal waveform and correct them for the entire system. |
| Pulses with defects such as chattering are being input. | Check the input signal waveform and remove chattering from external circuitry. |

Instantaneous Values Do Not Change.

| Probable cause | Remedy |
|--|---|
| The gain for span adjustment is set to 0. | Set the gain for span adjustment to a value other than 0. |
| The instantaneous value when input 100%, or the maximum instantaneous value in the range, is set to 0. | Set the instantaneous value when input 100%, and the maximum instantaneous value in the range, to a value other than 0. |

Instantaneous Values are Not Converted as Intended.

| Probable cause | Remedy |
|---|---|
| The instantaneous value when input 100%, or the maximum instantaneous value scaling value, is incorrect. | Check the instantaneous value when input 100%, the decimal point position, and the maximum instantaneous value scaling value. |
| The zero/span adjustment data is incorrect. | Check and correct the zero/span adjustment settings. |
| Input pulses are too slow (i.e., the pulse rate is too low). | Lengthen the instantaneous value time unit (conversion period). |
| There is pulsating in the instantaneous value. | Set the number of values for moving average processing. |
| When using pulse weight conversion for accumulated values, the value obtained from pulses x pulse weight per time unit is not set for the instantaneous value for 100% input. | Set the instantaneous value for 100% input as pulses x pulse weight/time unit. |

2-17 CS1W-PMV01 Isolated-type Analog Output Unit

Overview

Each cycle, the CS1W-PMV01 Isolated-type Analog Output Unit converts up to four analog output set values from the CPU Unit to either 4 to 20 mA or 1 to 5 V, and outputs them. It can also provide answer back for checking actual output values.

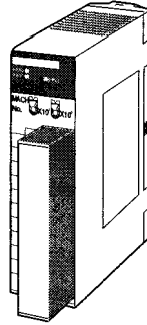

CS1W-PMV01

System Configuration

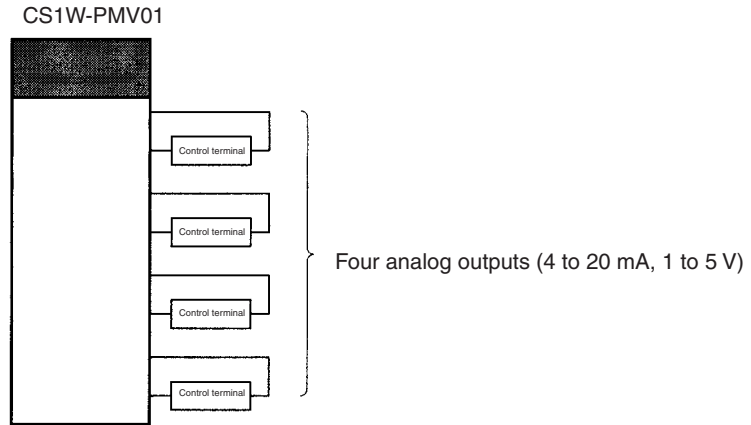

Features

- Outputs in either 4 to 20 mA or 1 to 5 V (set separately for each of the four outputs) the analog output values set in the allocated words of the CPU Unit's CIO Area.
- Answer input function.
Actual output signals of 4 to 20 mA or 1 to 5 V are checked by being read again from the output circuit, and are stored in the allocated words in the CIO Area. Mean value processing is also possible.
- Output disconnection detection function (current output only).
- Output high/low limit function.
- Rate-of-change limit function.
- Output hold function when CPU Unit errors occur.
When a CPU Unit fatal error (including FALS execution), or a CPU error in the CPU Unit occurs, or all outputs are turned OFF with the Output OFF Bit, this function can hold either a preset value or the analog output value prior to the error.
- Zero/span adjustment capability during operation.

Model Information

| Unit classification | Model number | Outputs | Outputs |
|----------------------------|--------------|---------|--|
| CS-series Special I/O Unit | CS1W-PMV01 | 4 | 4 to 20 mA, 1 to 5 V (separate for each of four outputs) |

Block Diagram (Order of Processing)

The processing for the four outputs is as shown in the following diagram.

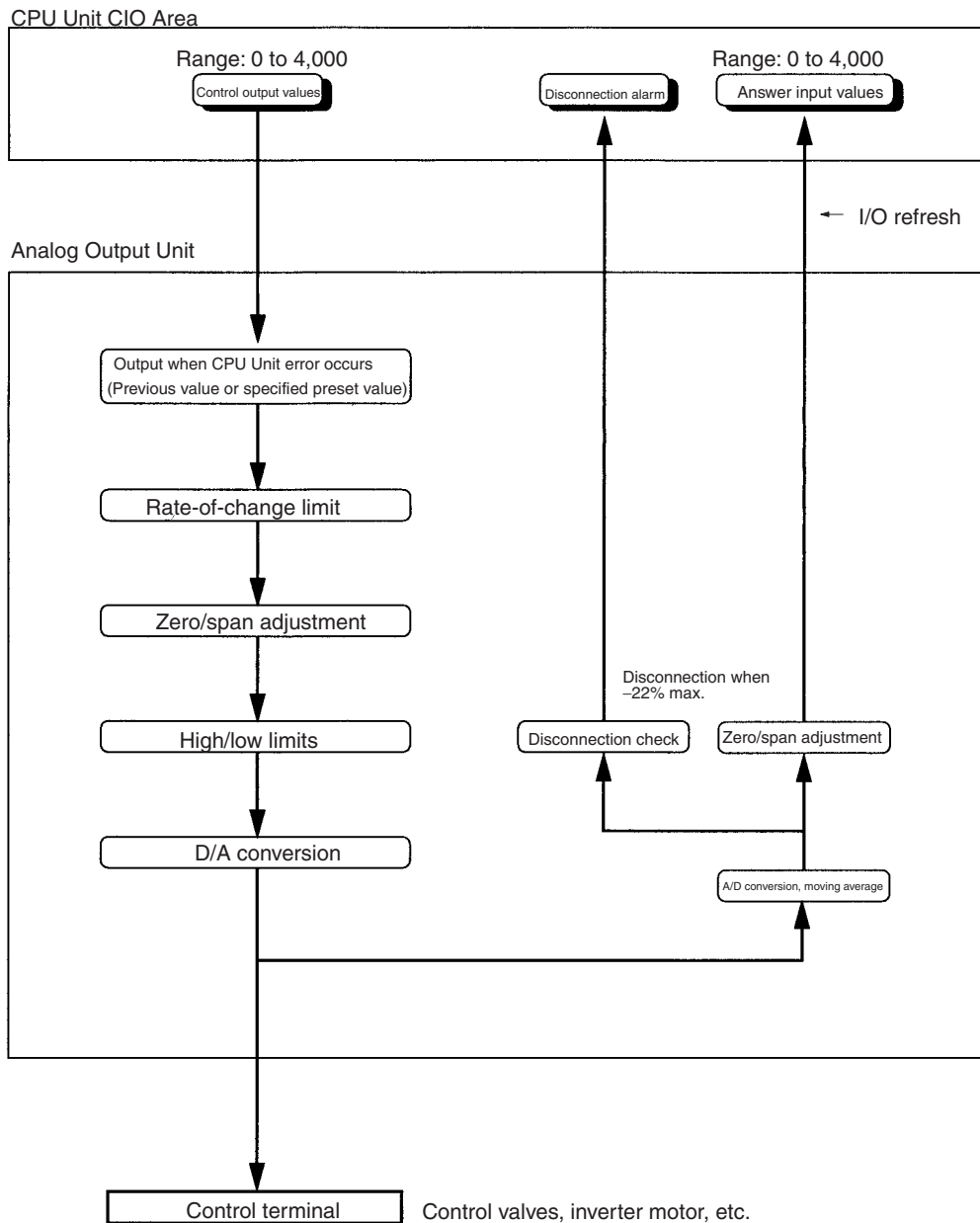

Specifications

| Item | | Specifications |
|--|--|---|
| Model | | CS1W-PMV01 |
| Applicable PLC | | CS Series |
| Unit classification | | CS-series Special I/O Unit |
| Mounting position | | CS-series CPU Rack or CS-series Expansion Rack (Cannot be mounted to C200H Expansion I/O Rack or SYSMAC BUS Remote I/O Slave Rack.) |
| Maximum number of Units | | 80 (within the allowable current consumption and power consumption range) |
| Unit numbers | | 00 to 95 (Cannot duplicate Special I/O Unit numbers.) |
| Areas for data exchange with CPU Unit | Special I/O Unit Area | 10 words/Unit CPU Unit to Analog Output Unit: Analog output values for each output Analog Output Unit to CPU Unit: Answer input values for each output, output disconnection |
| | DM Area words allocated to Special I/O Units | 100 words/Unit CPU Unit to Analog Output Unit: Output hold for when CPU Unit error occurs, high/low limit values, rate-of-change limit values (positive and negative directions), number of values for answer input moving average, zero/span adjustment for control outputs and answer inputs, etc. |
| Number of outputs | | 4 |
| Output signal types | | Either 4 to 20 mA or 1 to 5 V (separate for each of the four outputs). Switched according to the connection terminals. |
| User-defined scaling in industrial units | | None |
| Data storage in the CIO Area | | 0 to 4,000 (0000 to 0FA0 hex), fixed 0: 4 mA or 1 V; 4,000: 20 mA or 5 V The values derived from carrying out the following processing in order of the values in the allocated words in the CIO Area are output in analog. 1) Output hold → 2) Rate-of-change limit → 3) Zero/span adjustment → 4) High/low limits Therefore, the values after processing are confirmed by analog inputs. |
| Accuracy (25°C) | | When 4 to 20 mA: $\pm 0.1\%$ of full scale When 1 to 5 V: $\pm 0.2\%$ of full scale |
| Temperature coefficient | | $\pm 0.015\%/^{\circ}\text{C}$ of full scale |
| Resolution | | 1/4,000 of full scale |
| Warmup time | | 10 min |
| Output response time | | 0.2 s (travel time from output 0% to 100%, for step output) |
| D/A conversion period | | 100 ms/4 outputs |
| Maximum time to store data in CPU Unit | | Conversion period + one CPU Unit cycle |
| Output signal range | | Approx. -20 to 115% |
| Allowable load resistance | | When 4 to 20 mA: 404 Ω max. (when output range is -20 to 115%) or 458 Ω max. (when output range is -20 to 100%) (Refer to note.) When 1 to 5 V: 250 k Ω max. |
| Output impedance | | When 1 to 5 V: 250 Ω (typical) |
| Voltage when open between terminals | | Approx. 15 V |
| Answer input function | | The actual analog output values (4 to 20 mA or 1 to 5 V) from the Unit's output terminals can be read. Data stored to allocated words of CIO Area: 0 to 4,000 (0000 to 0FA0 hex), fixed. (When 4 mA or 1 V: 0; when 20 mA or 5 V: 4,000) Accuracy: $\pm 0.2\%$ of full scale Resolution: 1/2000 Temperature coefficient: $\pm 0.015\%/^{\circ}\text{C}$ |

| Item | | Specifications |
|---|------------------------|--|
| Current output disconnection detection function | | When the actual output of 4 to 20 mA from the Analog Output Unit's output terminals is 0.5 mA or less, it is regarded as an external output circuit current loop disconnection, and the Output Disconnection Flag turns ON. |
| Function | Rate-of-change limit | This function can be used to control the speed of up and down changes in analog output values. |
| | Output high/low limits | This function can be used to place high and low limits on analog output values. |
| | Output hold | This function holds the analog output value to the previous value or to a specified preset value when any of the following CPU Unit errors occurs, and outputs the analog output value in the CIO Area when the error is cleared. <ul style="list-style-type: none"> • CPU Unit fatal error (including FALS execution) • CPU error in CPU Unit • All outputs turned OFF with Output OFF Bit |
| Isolation | | Between outputs and between output terminals and PLC signals: Isolation by transformer and photocoupler |
| Insulation resistance | | 20 MΩ (at 500 V DC) between outputs |
| Dielectric strength | | Between outputs: 1,000 V AC, at 50/60 Hz, for 1 min, leakage current 10 mA max. |
| External connections | | Terminal block (detachable) |
| Unit number settings | | Set by rotary switches on front panel, from 0 to 95. |
| Indicators | | Three LED indicators on front panel (for normal operation, errors detected at the Analog Output Unit, and errors related to the CPU Unit). |
| Front panel connector | | Output connector terminal block (detachable) |
| Effect on CPU Unit cycle time | | 0.3 ms |
| Current consumption | | 5 V DC at 150 mA max., 26 V DC at 160 mA max. |
| Dimensions | | 35 × 130 × 126 mm (W × H × D) Note The height including the Backplane is 145 mm. |
| Weight | | 450 g max. |
| Standard accessories | | None |

Note The following diagram shows the relationship between the allowable load resistance and the current output.

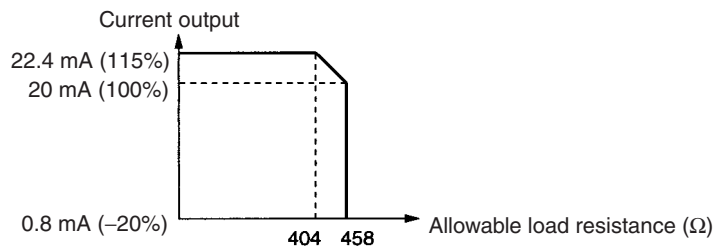

Output Values According to CPU Unit Status

Analog output values from the Analog Output Unit will be as shown in the following table, depending on the status of the CPU Unit.

| CPU Unit status | Analog output values from Unit | |
|---|--|---|
| Fatal error (including FALS(007) execution) | The output hold function holds the previous value or a specified preset value. | |
| CPU error | | |
| All outputs turned OFF with Output OFF Bit | | |
| Change of operation mode from RUN or Monitor to Program (See note.) | When the CPU Unit's I/O Memory Hold Flag (A500.12) is OFF. | The output value in the CIO Area is cleared, and that value (0000 hex) is output refreshed. |
| | When the CPU Unit's I/O Memory Hold Flag (A500.12) is ON. | The output value in the CIO Area is held at the value prior to the operation mode change, and that is output refreshed. |
| Fatal error or CPU standby after turning ON the power supply | Either 0 mA or 0 V is output. | |
| Special I/O Unit cyclic refresh disabled | Outputs can be refreshed by means of IORF(097) in the ladder diagram program. | |

Note Regardless of the CPU Unit's operation mode (including Program Mode), the analog output value in the allocated words of the CIO Area is always output refreshed. As shown in the above table, however, when the operation mode is changed to Program Mode, the analog output value in the CIO Area is either cleared or held depending on the status of the CPU Unit's I/O Memory Hold Flag (A500.12). In particular, be careful when this flag is ON, because the value prior to the mode change will be held and that value will be output refreshed.

DM Area Allocations

$$m = D20000 + \text{unit number} \times 100 \text{ (unit number: 0 to 95)}$$

| Output No. 1 | Output No. 2 | Output No. 3 | Output No. 4 | Decimal | Hexadecimal | Default | Data contents |
|---|--------------|--------------|--------------|---------------|------------------------------------|------------------|--|
| m | | | | 12345, 0 | 3039, 0000 hex | 0000 hex | Default block read command Specifies the direction of data transfer when the PLC is turned ON or the Unit is restarted for DM words m+2 to m+45. <ul style="list-style-type: none"> 12345 (3039 hex): The data in words m+2 to m+45 is transferred from the Analog Output Unit to the CPU Unit. When the transfer is completed, the value will become 0000 hex. Other than 12345 (3039 hex) (such as 0000 hex): The data in the allocated words of DM Area is transferred from the CPU Unit to the Analog Output Unit. |
| Setting Group 1 (continuously refreshed area): Parameters that are continuously refreshed during PLC operation (regardless of the CPU Unit's operation mode) | | | | | | | |
| | | | | | | | Analog output zero/span adjustment |
| m + 2 | m + 6 | m + 10 | m + 14 | 0 to 32000 | 0000 to 7D00 hex | 10000 (2710 hex) | Gain for span adjustment (set value x 0.0001) |
| m + 3 | m + 7 | m + 11 | m + 15 | -4000 to 4000 | F060 to FFFF hex, 0000 to 0FA0 hex | 0 (0000 hex) | Zero adjustment value (Set in units of analog output value resolution.) |
| | | | | | | | Answer input zero/span adjustment |
| m + 4 | m + 8 | m + 12 | m + 16 | 0 to 32000 | 0000 to 7D00 hex | 10000 (2710 hex) | Gain for span adjustment (set value x 0.0001) |
| m + 5 | m + 9 | m + 13 | m + 17 | -4000 to 4000 | F060 to FFFF hex, 0000 to 0FA0 hex | 0 (0000 hex) | Zero adjustment value (Set in units of analog output value resolution.) |

| Output No. 1 | Output No. 2 | Output No. 3 | Output No. 4 | Decimal | Hexadecimal | Default | Data contents |
|--|--------------|--------------|--------------|--------------|------------------------------------|------------------|---|
| Setting Group 2 (initial settings area): Parameters that are transferred one time from the CPU Unit to the Analog Output Unit if word m contains other than 12345 when the PLC is turned ON or the Analog Output Unit is restarted. | | | | | | | |
| | | | | | | | Output hold function |
| m + 18 | m + 25 | m + 32 | m + 39 | 0, 1 | 0000 to 0001 hex | 1 (0001 hex) | Output hold value 0: Hold at previous value. 1: Hold at specified preset value (below). |
| m + 19 | m + 26 | m + 33 | m + 40 | -800 to 4600 | FCE0 to FFFF hex, 0000 to 11F8 hex | -800 (FCE0 hex) | Preset output value for output hold function |
| | | | | | | | High/low limit function |
| m + 20 | m + 27 | m + 34 | m + 41 | -800 to 4600 | FCE0 to FFFF hex, 0000 to 11F8 hex | 4600 (11F8 hex) | High limit |
| m + 21 | m + 28 | m + 35 | m + 42 | -800 to 4600 | FCE0 to FFFF hex, 0000 to 11F8 hex | -800 (FCE0 hex) | Low limit |
| | | | | | | | Rate-of-change limit function |
| m + 22 | m + 29 | m + 36 | m + 43 | 0 to 32000 | 0000 to 7D00 hex | 32000 (7D00 hex) | Positive rate-of-change limit (unit: 1 s) |
| m + 23 | m + 30 | m + 37 | m + 44 | 0 to 32000 | 0000 to 7D00 hex | 32000 (7D00 hex) | Negative rate-of-change limit (unit: 1 s) |
| | | | | | | | Answer input mean value processing |
| m + 24 | m + 31 | m + 38 | m + 45 | 1 to 16 | 0001 to 0010 hex | 4 (0004 hex) | Number of values for answer input moving average |
| Storage parameter | | | | | | | |
| m + 46 | m + 47 | m + 48 | m + 49 | 0 to 45 | 0000 to 002D hex | 0 (0000 hex) | Address of Data Range Error (See note.) |

Note The ERC indicator on the Unit's front panel will light if an out-of-range setting is made in either Setting Group 1 or 2. The offset from word m to the first word containing the out-of-range error will be stored as the Address of Data Range Error in the DM Area in four digits hexadecimal. For more information, refer to 1-6 Error Processing.

CIO Area Allocations

$$n = 2000 + \text{unit number} \times 10 \text{ (unit number: 0 to 95)}$$

| Direction | Wd | Bit | Name | Data range | Contents | |
|--------------------------------|-------|----------|---------------------------|---------------------------------|--|-------------------------------|
| CPU Unit to Analog Output Unit | n | 00 to 15 | Not used. | --- | --- | |
| | n + 1 | 00 to 15 | No. 1 analog output value | -800 to 4600 (FCE0 to 11F8 hex) | Set from 0 to 4,000 (0000 to 0FA0 hex). This value is processed as follows: Output hold → rate-of-change limit → zero/span adjustment → high/low limit. Then an analog signal is output as either 4 to 20 mA or 1 to 5 V. | |
| | n + 2 | 00 to 15 | No. 2 analog output value | -800 to 4600 (FCE0 to 11F8 hex) | | |
| | n + 3 | 00 to 15 | No. 3 analog output value | -800 to 4600 (FCE0 to 11F8 hex) | | |
| | n + 4 | 00 to 15 | No. 4 analog output value | -800 to 4600 (FCE0 to 11F8 hex) | | |
| Analog Output Unit to CPU Unit | n + 5 | 00 to 15 | No. 1 answer input value | -800 to 4600 (FCE0 to 11F8 hex) | The actual analog output signal is input and stored as a value from 0 to 4,000 (0000 to 0FA0 hex), for either 4 to 20 mA or 1 to 5 V. | |
| | n + 6 | 00 to 15 | No. 2 answer input value | -800 to 4600 (FCE0 to 11F8 hex) | | |
| | n + 7 | 00 to 15 | No. 3 answer input value | -800 to 4600 (FCE0 to 11F8 hex) | | |
| | n + 8 | 00 to 15 | No. 4 answer input value | -800 to 4600 (FCE0 to 11F8 hex) | | |
| | n + 9 | 00 | | No. 1 output disconnection | 0, 1 | 0: Normal 1: Disconnection |
| | | 01 | | No. 2 output disconnection | 0, 1 | |
| | | 02 | | No. 3 output disconnection | 0, 1 | |
| | | 03 | | No. 4 output disconnection | 0, 1 | |

Terminal Block Diagram

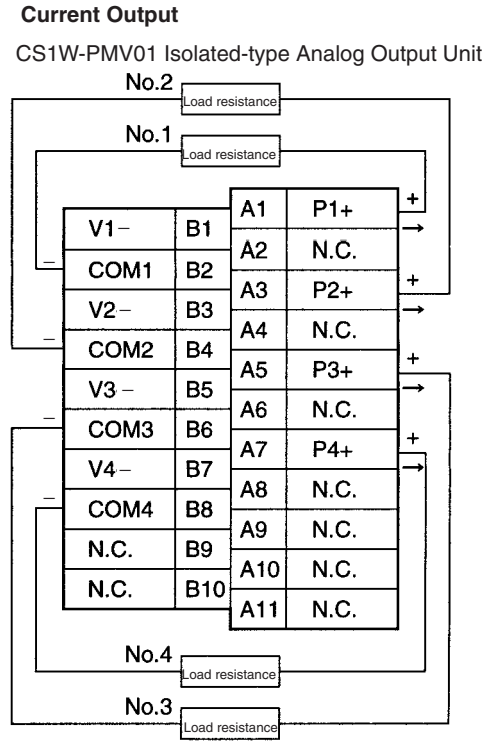
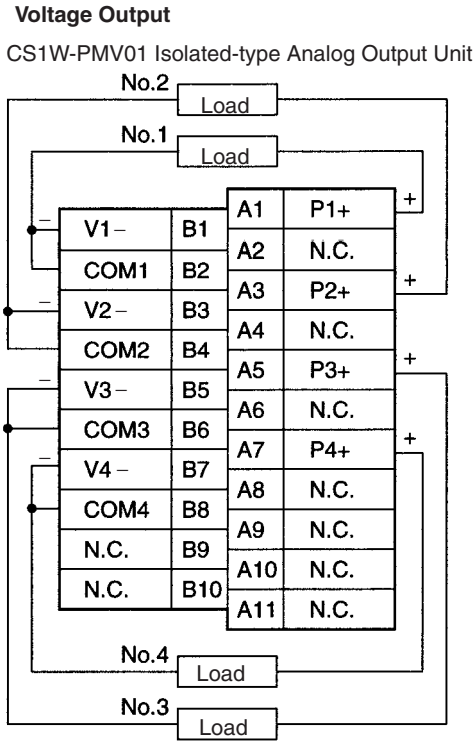

Note In both of the above cases, short-circuit all unused inputs between V□ and COM□ (e.g., between terminals B1 and B2 for output No. 1) with the lead wire.

Terminal Block Diagram

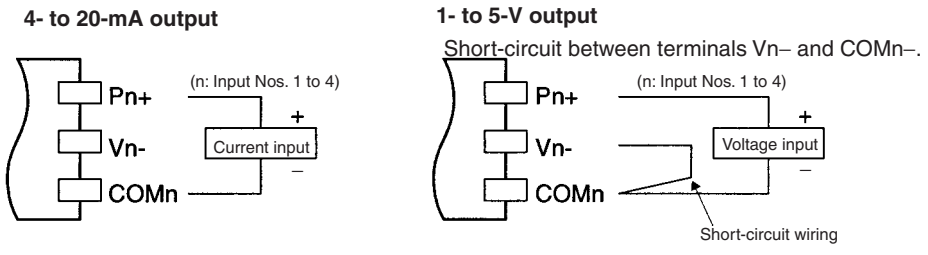
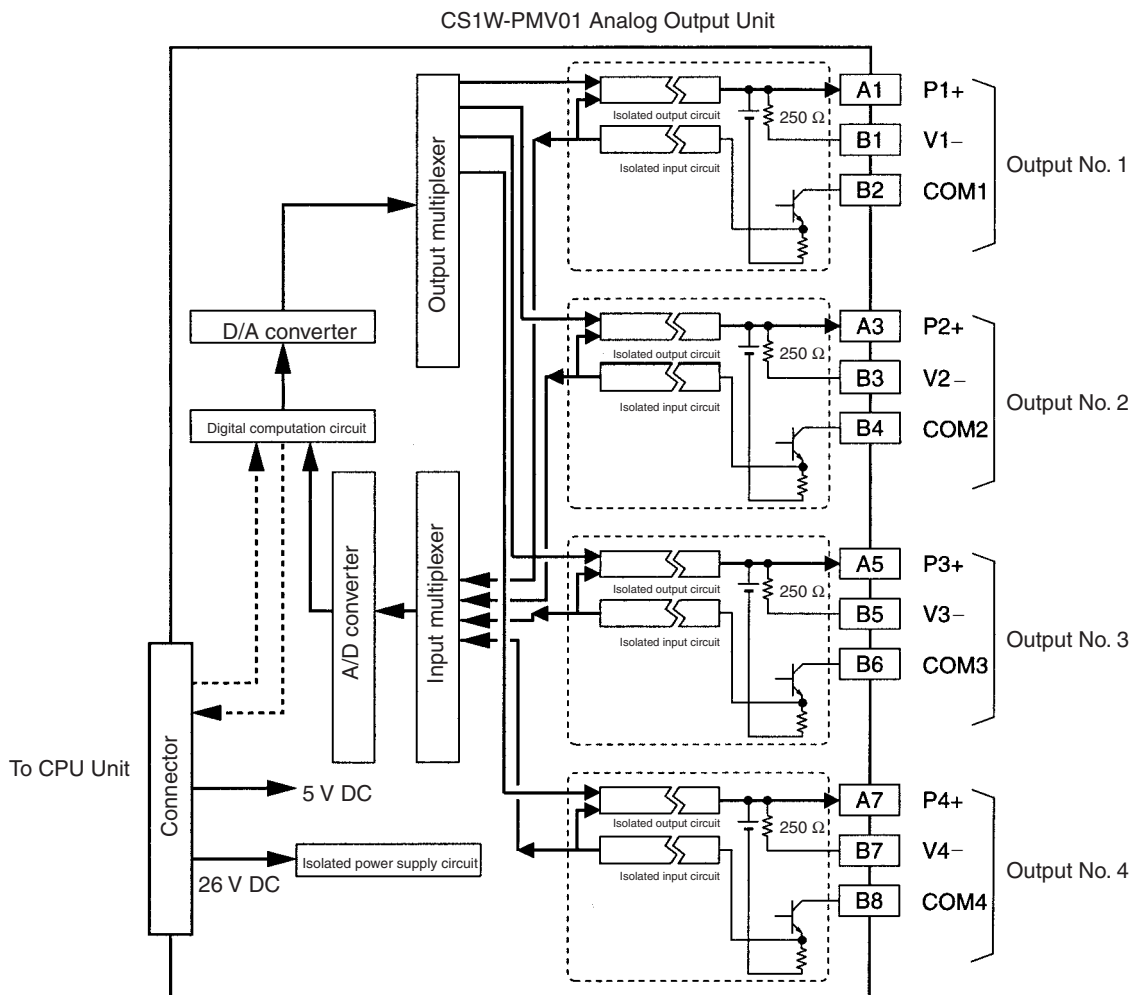

Error Processing

Outputs Do Not Change.

| Probable cause | Remedy |
|---|--|
| The span adjustment value in the output zero/span adjustment is set to 0. | Set the span adjustment to the Unit's default value. |
| The high/low limit is operating. | Set the high/low limit to the Unit's default value. |
| The output data is set out of range. | Correct the data so that it falls within the range. |
| All outputs have been turned OFF with the Output OFF Bit. | Turn OFF the Output OFF Bit. |

Outputs are Not Converted as Intended.

| Probable cause | Remedy |
|---|--|
| The span adjustment value in the output zero/span adjustment is set to 0. | Set the span adjustment to the Unit's default value. |
| An output device's I/O specifications do not conform. | Check the load impedance. Change the remote device. |
| The rate-of-change limit is too low, and the change is too slow. | Correct the rate-of-change limit setting. |

Outputs are Unstable.

| Probable cause | Remedy |
|--|--|
| Output signals are being affected by external noise. | Change the connection paths of the output signal lines. (Separate them from sources of noise or use shielded cable.) |

Answer Input Data Does Not Change.

| Probable cause | Remedy |
|---|--|
| The gain for span adjustment is set to 0. | Set the gain for span adjustment to a value other than 0. |
| An output device is malfunctioning, output wiring is faulty, or wiring is disconnected. | Check whether the output voltage or current has changed. Check for faulty or disconnected wiring. Check whether a disconnection has been detected in the I/O Area. |

Values are Not Converted as Intended.

| Probable cause | Remedy |
|---|--|
| The zero/span adjustment, high/low limit, or rate-of-change value is incorrect. | Check and correct the settings. |
| An output device's I/O specifications do not conform. | Check the load impedance. Change the remote device. |

Converted Values are Unstable.

| Probable cause | Remedy |
|--|--|
| Output signals are being affected by external noise. | Change the connection paths of the output signal lines. (Separate them from sources of noise or use shielded cable.) |
| | Increase the number of values for calculating the moving average in mean value processing. |

2-18 CS1W-PMV02 Isolated-type Analog Output Unit

Overview

Each cycle, the CS1W-PMV02 Isolated-type Analog Output Unit converts up to four analog output set values from the CPU Unit to analog voltage signals and outputs them.

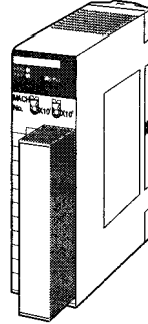

CS1W-PMV02

System Configuration

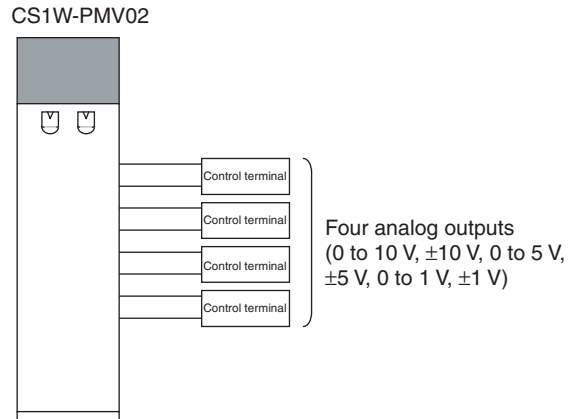

Features

- Outputs the analog output values set in the allocated words of the CPU Unit's CIO Area. (Supported output ranges: -10 to 10 V, 0 to 10 V, -5 to 5 V, 0 to 5 V, -1 to 1 V, 0 to 1 V.)
- Output high/low limit function.
- Rate-of-change limit function.
- Output hold function when CPU Unit errors occur.
When a CPU Unit fatal error (including FALS execution), or a CPU error in the CPU Unit occurs, or all outputs are turned OFF with the Output OFF Bit, this function can hold either a preset value or the analog output value prior to the error.
- Zero/span adjustment capability during operation.

Model Information

| Unit classification | Model number | Outputs | Outputs |
|----------------------------|--------------|---------|--|
| CS-series Special I/O Unit | CS1W-PMV02 | 4 | -10 to 10 V, 0 to 10 V, -5 to 5 V, 0 to 5 V, -1 to 1 V, 0 to 1 V |

Block Diagram (Order of Processing)

The processing for the four outputs is as shown in the following diagram.

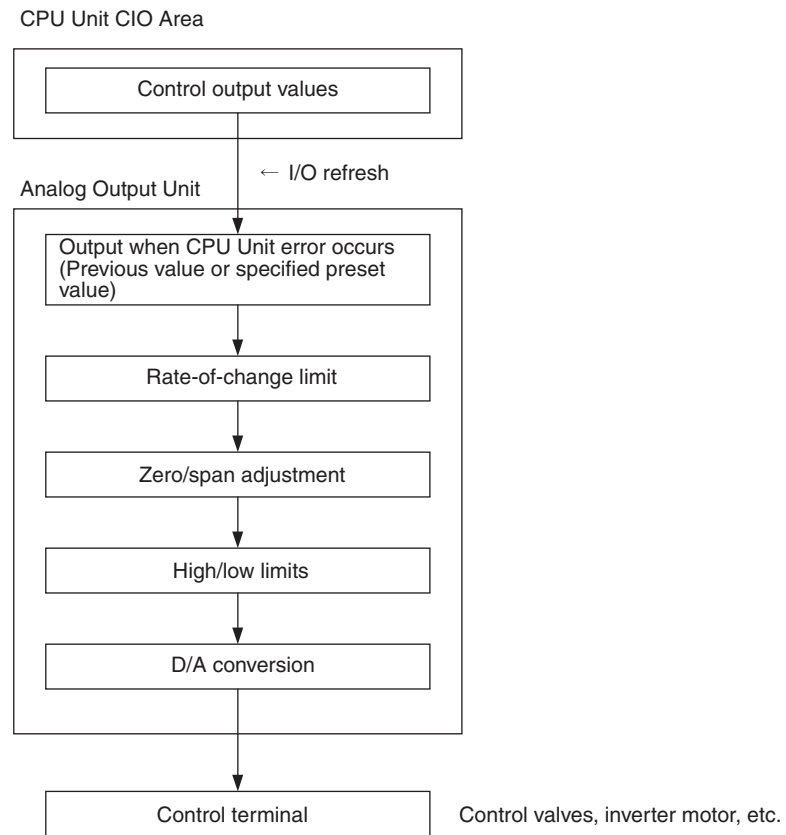

Specifications

| Item | | Specifications |
|---|--|---|
| Model | | CS1W-PMV02 |
| Applicable PLC | | CS Series |
| Unit classification | | CS-series Special I/O Unit |
| Mounting position | | CS-series CPU Rack or CS-series Expansion Rack (Cannot be mounted to C200H Expansion I/O Rack or SYSMAC BUS Remote I/O Slave Rack.) |
| Maximum number of Units | | 80 (within the allowable current consumption and power consumption range) |
| Unit numbers | | 00 to 95 (Cannot duplicate Special I/O Unit numbers.) |
| Areas for data exchange with CPU Unit | Special I/O Unit Area | 10 words/Unit CPU Unit to Analog Output Unit: Analog output values for each output Analog Output Unit to CPU Unit: None |
| | DM Area words allocated to Special I/O Units | 100 words/Unit CPU Unit to Analog Output Unit: Output hold for when CPU Unit error occurs, high/low limit values, rate-of-change limit values, zero/span adjustment for control outputs, etc. |
| Number of outputs | | 4 |
| Output signal types | | 0 to 10 V, 0 to 5 V, 0 to 1 V, -10 to 10 V, -5 to 5 V, -1 to 1 V (Each output point can be set individually.) |
| User-defined scaling in industrial units | | Scaling is possible for each of the above signal types individually. (The data corresponding to the minimum and maximum output values can be set freely.) |
| Data storage in the CIO Area | | ±32,000 (8300 to FFFF hex, 0000 to 7D00 hex) |
| Accuracy (25°C) | | ±0.1% of full scale |
| Temperature coefficient | | ±0.015%/°C of full scale |
| Resolution | | -10 to 10 V, -1 to 1 V: 1/16,000 of full scale 0 to 10 V, 0 to 1 V, -5 to 5 V: 1/8,000 of full scale 0 to 5 V: 1/4,000 of full scale |
| Warmup time | | 10 min |
| Output response time | | 50 ms max. (travel time from output 0% to 90%, for step output) |
| D/A conversion period | | 40 ms/4 outputs |
| Maximum output delay time | | Output response time + conversion period + one CPU Unit cycle |
| Output signal range | | -15 to 115% (-7.5 to 107.5% for ±10-V and ±1-V ranges) |
| Allowable load resistance | | 10 kΩ min. |
| Output impedance | | 0.5 Ω max. |
| Voltage when open between terminals | | --- |
| Answer input function | | None |
| Current output disconnection detection function | | None |
| Function | Rate-of-change limit | This function can be used to control the speed of up and down changes in analog output values. |
| | Output high/low limits | This function can be used to place high and low limits on analog output values. |
| | Output hold | This function holds the analog output value to the previous value or to a specified preset value when any of the following CPU Unit errors occurs. Normal operation is restored when the CPU Unit error is cleared. <ul style="list-style-type: none"> • CPU Unit fatal error (including FALS execution) • CPU error in CPU Unit • CPU Unit's load interrupted |
| Isolation | | Between outputs and between output terminals and PLC signals: Isolation by transformer and photocoupler |

| Item | Specifications |
|-------------------------------|--|
| Insulation resistance | 20 MΩ (at 500 V DC) between outputs |
| Dielectric strength | Between outputs: 1,000 V AC, at 50/60 Hz, for 1 min, leakage current 10 mA max. |
| External connections | Terminal block (detachable) |
| Unit number settings | Set by rotary switches on front panel, from 0 to 95. |
| Indicators | Three LED indicators on front panel (for normal operation, errors detected at the Analog Output Unit, and errors related to the CPU Unit). |
| Front panel connector | Output connector terminal block (detachable) |
| Effect on CPU Unit cycle time | 0.3 ms |
| Current consumption | 5 V DC at 120 mA max., 26 V DC at 120 mA max. |
| Dimensions | 35 × 130 × 126 mm (W × H × D) Note The height including the Backplane is 145 mm. |
| Weight | 450 g max. |
| Standard accessories | None |

Output Values According to CPU Unit Status

Analog output values from the Analog Output Unit will be as shown in the following table, depending on the status of the CPU Unit.

| CPU Unit status | Analog output values from Unit | |
|---|--|---|
| Fatal error (including FALS(007) execution) | The output hold function holds the previous value or a specified preset value. | |
| CPU error | | |
| All outputs turned OFF with Output OFF Bit | | |
| Change of operation mode from RUN or Monitor to Program (See note.) | When the CPU Unit's I/O Memory Hold Flag (A500.12) is OFF. | The output value in the CIO Area is cleared, and that value (0000 hex) is output refreshed. |
| | When the CPU Unit's I/O Memory Hold Flag (A500.12) is ON. | The output value in the CIO Area is held at the value prior to the operation mode change, and that is output refreshed. |
| Fatal error or CPU standby after turning ON the power supply | 0 V is output. | |
| Special I/O Unit cyclic refresh disabled | Outputs can be refreshed by means of IORF(097) in the ladder diagram program. | |

Note Regardless of the CPU Unit's operation mode (including Program Mode), the analog output value in the allocated words of the CIO Area is always output refreshed. As shown in the above table, however, when the operation mode is changed to Program Mode, the analog output value in the CIO Area is either cleared or held depending on the status of the I/O Memory Hold Flag (A500.12). In particular, be careful when this flag is ON, because the value prior to the mode change will be held and that value will be output refreshed.

DM Area Allocations

m = D20000 + unit number × 100 (unit number: 0 to 95)

| Input No. 1 | Input No. 2 | Input No. 3 | Input No. 4 | Decimal | Hexadecimal | Default | Data contents |
|---|-------------|-------------|-------------|------------------|--|------------------|---|
| m | | | | 12345, 0 | 3039, 0000 hex | 0000 hex | Default block read command Specifies the direction of data transfer when the PLC is turned ON or the Unit is restarted for DM words m+2 to m+61. <ul style="list-style-type: none"> 12345 (3039 hex): The data in words m+2 to m+61 is transferred from the Analog Output Unit to the CPU Unit. When the transfer is completed, the value will become 0000 hex. Other than 12345 (such as 0000 hex): The data in the allocated words of DM Area is transferred from the CPU Unit to the Analog Output Unit. |
| Setting Group 1 (continuously refreshed area): Parameters that are continuously refreshed during PLC operation (regardless of the CPU Unit's operation mode) | | | | | | | |
| | | | | | | | Analog output zero/span adjustment |
| m + 2 | m + 6 | m + 10 | m + 14 | 1 to 32000 | 0001 to 7D00 hex | 10000 (2710 hex) | Gain for span adjustment (set value × 0.0001) |
| m + 3 | m + 7 | m + 11 | m + 15 | -16000 to 16000 | C180 to FFFF hex, 0000 to 3E80 hex | 0 (0000 hex) | Zero adjustment value (Set in units of analog output value resolution.) |
| Setting Group 2 (initial settings area): Parameters that are transferred one time from the CPU Unit to the Analog Output Unit if word m contains other than 12345 when the PLC is turned ON or the Analog Output Unit is restarted. | | | | | | | |
| | | | | | | | Output hold function |
| m + 18 | m + 25 | m + 32 | m + 39 | 0, 1 | 0000 to 0001 hex | 1 (0001 hex) | Output hold value 0: Hold at previous value. 1: Hold at specified preset value (below). |
| m + 19 | m + 26 | m + 33 | m + 40 | -32000 to 32000 | 8300 to FFFF hex, 0000 to 7D00 hex | -600 (FDA8 hex) | Preset output value for output hold function |
| | | | | | | | High/low limit function |
| m + 20 | m + 27 | m + 34 | m + 41 | -32000 to 32000 | 8300 to FFFF hex, 0000 to 7D00 hex | 4600 (11F8 hex) | High limit |
| m + 21 | m + 28 | m + 35 | m + 42 | -32000 to 32000 | 8300 to FFFF hex, 0000 to 7D00 hex | -600 (FDA8 hex) | Low limit |
| | | | | | | | Rate-of-change limit function |
| m + 22 | m + 29 | m + 36 | m + 43 | 0 to 32000 | 0000 to 7D00 hex | 32000 (7D00 hex) | Positive rate-of-change limit (unit: 1 s) |
| m + 23 | m + 30 | m + 37 | m + 44 | 0 to 32000 | 0000 to 7D00 hex | 32000 (7D00 hex) | Negative rate-of-change limit (unit: 1 s) |
| Display Parameter | | | | | | | |
| m + 46 | m + 47 | m + 48 | m + 49 | 0 to 61 | 0000 to 003D | 0 (0000 hex) | Address display for data range error |
| Expansion Settings (initial settings area): Parameters that are transferred one time from the CPU Unit to the Analog Output Unit if word m contains other than 12345 when the PLC is turned ON or the Analog Output Unit is restarted. | | | | | | | |
| | | | | | | | Output signal type |
| m + 50 | m + 53 | m + 56 | m + 59 | 0, 1, 2, 3, 8, 9 | 0000 hex 0001 hex 0002 hex 0003 hex 0008 hex 0009 hex | 1 (0001 hex) | 0: -10 to 10 V 1: 0 to 10 V 2: -5 to 5 V 3: 0 to 5 V 8: -1 to 1 V 9: 0 to 1 V |
| | | | | | | | Output data scaling |
| m + 51 | m + 54 | m + 57 | m + 60 | -32000 to 32000 | 8300 to FFFF hex, 0000 to 7D00 hex | 4000 (0000 hex) | Setting data that corresponds to maximum output value (span) |
| m + 52 | m + 55 | m + 58 | m + 61 | -32000 to 32000 | 8300 to FFFF hex, 0000 to 7D00 hex | 0 (0000 hex) | Setting data that corresponds to minimum output value (zero) |

CIO Area Allocations

n = 2000 + unit number × 10 (unit number: 0 to 95)

| Direction | Wd | Bit | Name | Data range | Contents |
|--------------------------------|-------|----------|---------------------------|---|--|
| CPU Unit to Analog Output Unit | n | 00 to 15 | Not used. | --- | --- |
| | n + 1 | 00 to 15 | No. 1 analog output value | -32000 to 32000 (8300 to FFFF hex, 0000 to 7D00 hex) | Set from -32000 to 32000 (8300 to FFFF hex, 0000 to 7D00 hex). This value is processed as follows: Output hold → rate-of-change limit → zero/span adjustment → high/low limit. Then an analog signal is output. |
| | n + 2 | 00 to 15 | No. 2 analog output value | -32000 to 32000 (8300 to FFFF hex, 0000 to 7D00 hex) | |
| | n + 3 | 00 to 15 | No. 3 analog output value | -32000 to 32000 (8300 to FFFF hex, 0000 to 7D00 hex) | |
| | n + 4 | 00 to 15 | No. 4 analog output value | -32000 to 32000 (8300 to FFFF hex, 0000 to 7D00 hex) | |
| Analog Output Unit to CPU Unit | n + 5 | 00 to 15 | Not used. | --- | --- |
| | n + 6 | 00 to 15 | | | |
| | n + 7 | 00 to 15 | | | |
| | n + 8 | 00 to 15 | | | |
| | n + 9 | 00 to 15 | | | |

Terminal Connection Diagram

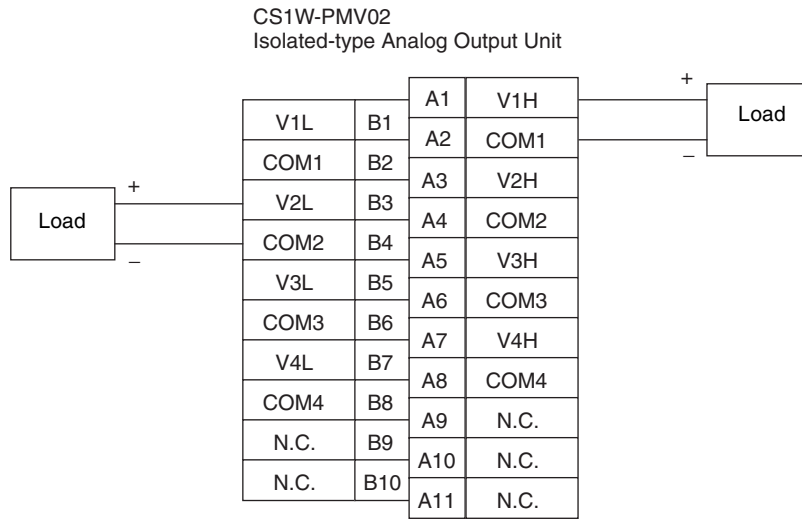

B terminals: 0 to 1 V, ±1 V; A terminals: 0 to 10 V, 0 to 5 V, ±10 V, ±5 V

- Note**
- Although signals 1/10 of the size of the A-row terminal output signals are output to the B terminals, simultaneous use of A (L) and B (H) terminals of the same number is prohibited.
 - Do not connect V□□ and COM□□ for all unused output numbers.

Terminal Block Diagram

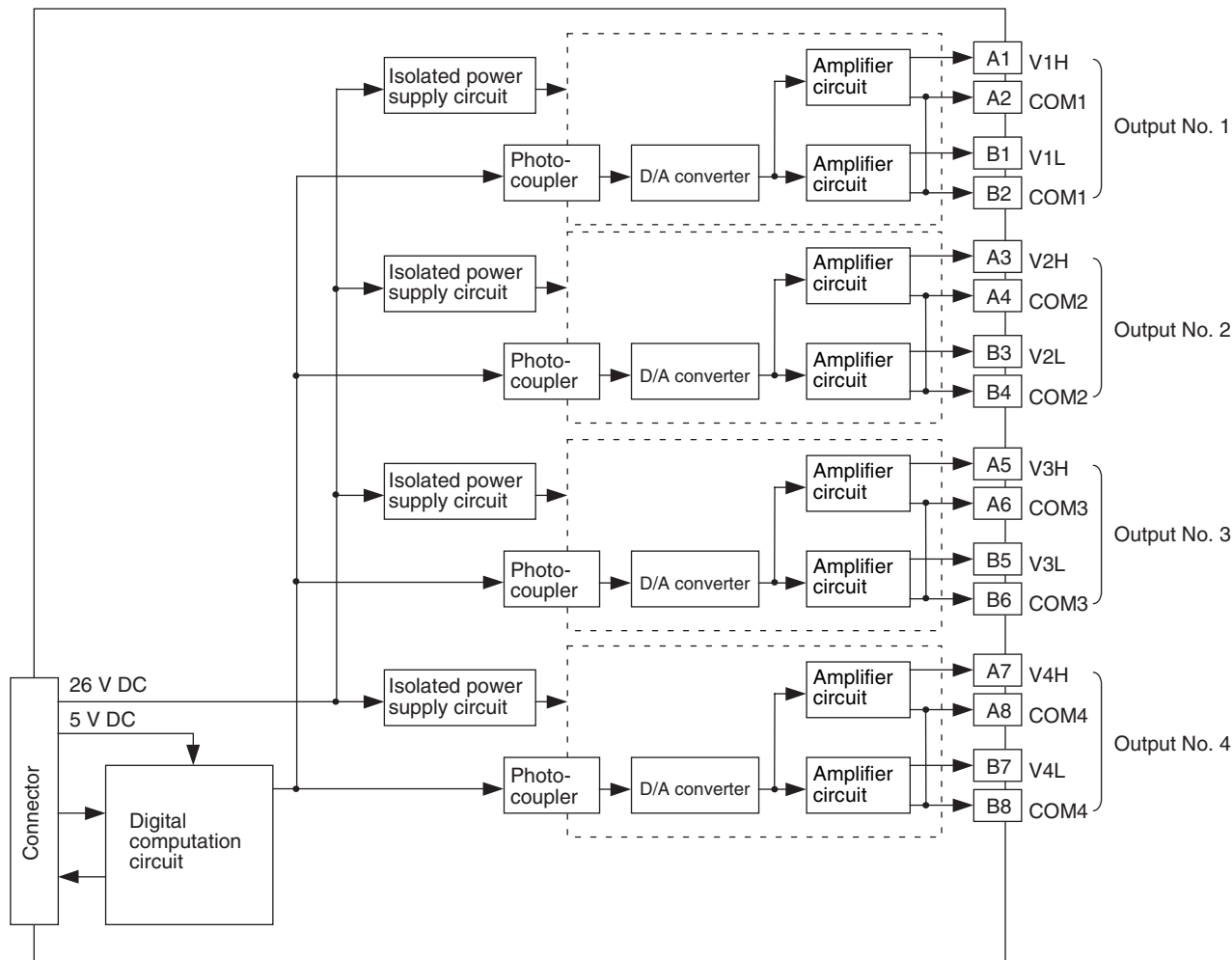

Error Processing

Outputs Do Not Change.

| Probable cause | Remedy |
|--|--|
| The span adjustment value in the output zero/ span adjustment is set to 0. | Set the span adjustment to the Unit's default value. |
| The high/low limit is operating. | Set the high/low limit to the Unit's default value. |
| The output data is set out of range. | Correct the data so that it falls within the range. |
| All outputs have been turned OFF with the Output OFF Bit. | Turn OFF the Output OFF Bit. |

Outputs are Not Converted as Intended.

| Probable cause | Remedy |
|--|--|
| The zero/span adjustment or high/low limit value is incorrect. | Check and correct the settings. |
| An output device's I/O specifications do not conform. | Check the load impedance. Change the remote device. |
| The rate-of-change limit is too low, and the change is too slow. | Correct the rate-of-change limit setting. |

Outputs are Unstable.

| Probable cause | Remedy |
|--|--|
| Output signals are being affected by external noise. | Change the connection paths of the output signal lines. (Separate them from sources of noise or use shielded cable.) |

SECTION 3

Individual Unit Descriptions for CJ Series

This section describes each of the CJ-series Analog I/O Units in detail.

| | | |
|-----|---|-----|
| 3-1 | CJ1W-PTS51 Isolated-type Thermocouple Input Unit | 276 |
| 3-2 | CJ1W-PTS15 Isolated-type Thermocouple Input Unit | 288 |
| 3-3 | CJ1W-PTS52 Isolated-type Resistance Thermometer Input Unit (Pt100, JPt100) | 302 |
| 3-4 | CJ1W-PTS16 Isolated-type Resistance Thermometer Input Unit (Pt100, JPt100, Pt50, Ni508.4) | 312 |
| 3-5 | CJ1W-PDC15 Isolated-type Direct Current Input Unit | 324 |
| 3-6 | CJ1W-PH41U Isolated-type Universal Input Unit | 338 |

3-1 CJ1W-PTS51 Isolated-type Thermocouple Input Unit

Overview

The CJ1W-PTS51 Isolated-type Thermocouple Input Unit provides four direct thermocouple inputs, and sends the data to the CPU Unit each cycle. All inputs are isolated.

CJ1W-PTS51

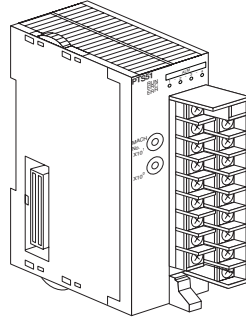

System Configuration

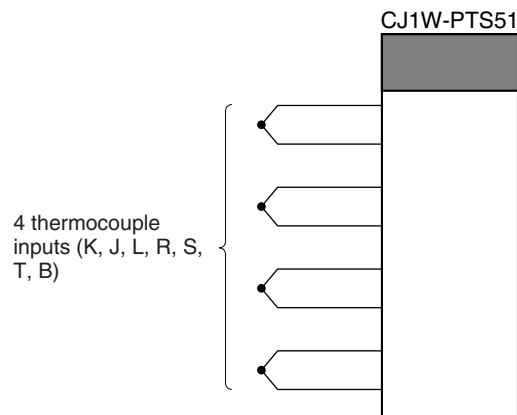

Features

- Up to four Thermocouples can be connected for each Unit. (The temperature sensor and input range settings are the same for all four inputs.)
- There is isolation between channels, so unwanted circuit paths between thermocouple inputs can be prevented.
- A variety of temperature specifications are supported. Any of the following can be selected for thermocouple input: K, J, L, R, S, T, B (Decimal points can be selected for K, J, and L.)
- Temperature sensor values are transmitted to the CPU Unit in four digits hexadecimal. (Binary or BCD can be selected for the data output format.)
- Process value alarm (with two internal alarms in memory and one external alarm output for each input)
- Alarm ON-delay timer and hysteresis for process value
- Zero/span adjustment capability during operation
- Sensor error detection
- Maximum or minimum process value can be specified for when a sensor error is detected.

Model Information

| Unit classification | Model number | Inputs | Temperature sensor types |
|----------------------------|--------------|--------|--|
| CJ-series Special I/O Unit | CJ1W-PTS51 | 4 | K, J, L, R, S, T, B (The same sensor type is used for all four inputs.) |

Block Diagram (Order of Processing)

The processing for the inputs is as shown in the following diagram.

CPU Unit

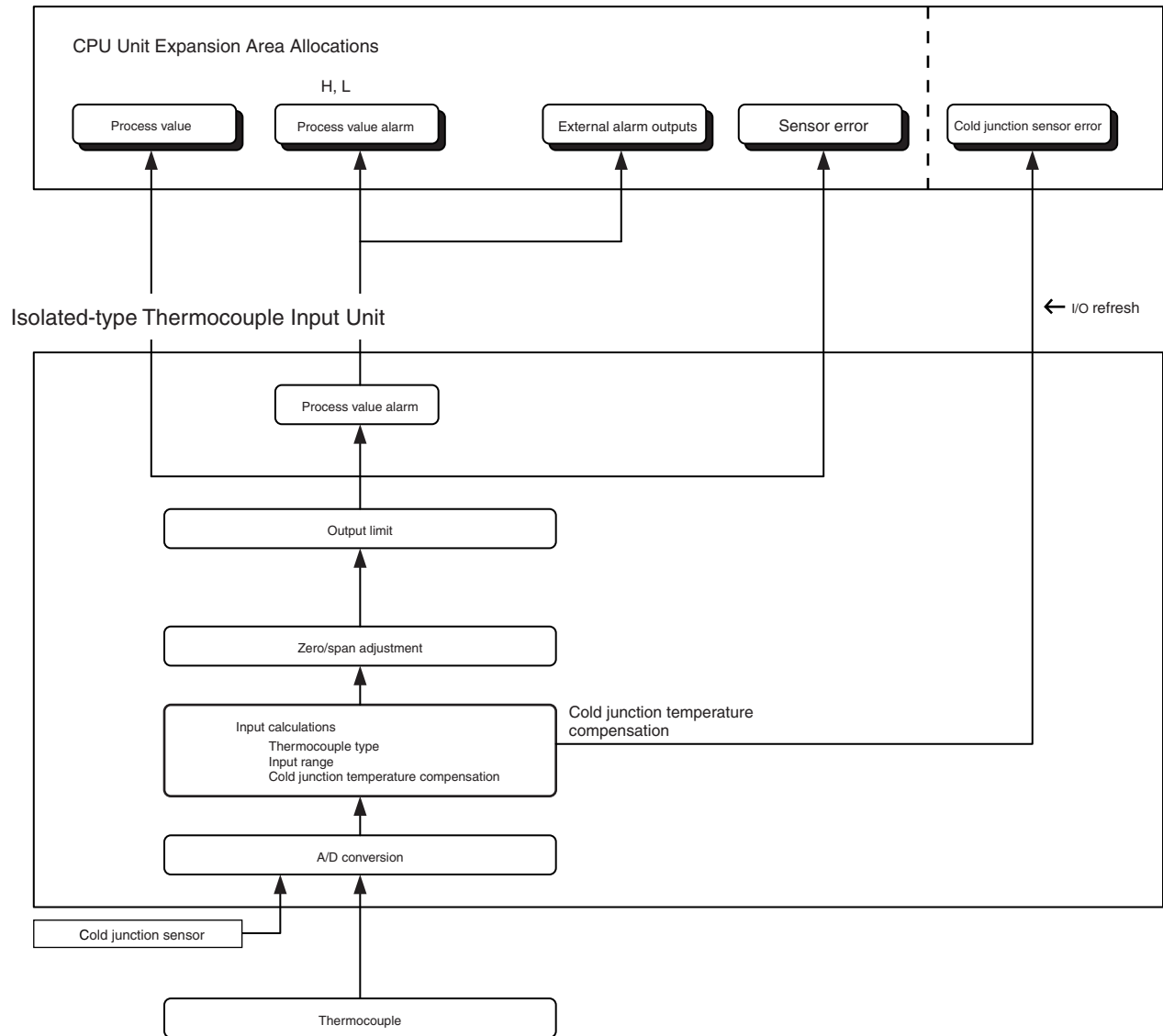

Specifications

| Item | | Specifications |
|--|--|--|
| Model | | CJ1W-PTS51 |
| Applicable PLC | | CJ Series |
| Unit classification | | CJ-series Special I/O Unit |
| Mounting position | | CJ-series CPU Rack or CJ-series Expansion Rack |
| Maximum number of Units | | 40 (within the allowable current consumption and power consumption range) |
| Unit numbers | | 00 to 95 (Cannot duplicate Special I/O Unit numbers.) |
| Areas for data exchange with CPU Unit | Special I/O Unit Area | 10 words/Unit Thermocouple Input Unit to CPU Unit: All process values, process value alarms (L, H), conversion data enabled flag, sensor errors, cold junction sensor errors |
| | DM Area words allocated to Special I/O Units | 100 words/Unit CPU Unit to Thermocouple Input Unit: Temperature sensor type, input range (same for all I/O), process value alarm setting (L, H), zero/span adjustment value. |
| Number of temperature sensor inputs | | 4 |
| Temperature sensor types | | Selectable from K, J, L, R, S, T, B. (Same setting for all inputs.) |
| Data storage in the CIO Area | | The actual process data in the input range is stored in four digits hexadecimal (binary or BCD values) in the allocated words in the CIO Area. |
| Accuracy (25°C) (See note.) | | With Celsius selected: $\pm 0.3\%$ of PV or $\pm 1^\circ\text{C}$, whichever is greater, ± 1 digit max. With Fahrenheit selected: $\pm 0.3\%$ of PV or $\pm 2^\circ\text{F}$, whichever is greater, ± 1 digit max. However, the accuracy of K and T at -100°C or lower and L is $\pm 2^\circ\text{C} \pm 1$ digit max. The accuracy of R and S at 200°C or lower is $\pm 3^\circ\text{C} \pm 1$ digit max. The accuracy of B at 400°C or lower is not specified. PV: Process value data |
| Temperature characteristics | | Refer to <i>Temperature Characteristics According to Thermocouple Type</i> on page 280. |
| Warmup time | | 30 min |
| Conversion period | | 250 ms/4 inputs. |
| Maximum time to store data in CPU Unit | | Conversion period + one CPU Unit cycle |
| Sensor error detection | | Detects sensor error at each input and turns ON the Sensor error Flag. Hardware detection time: Approx. 0.5 s max. The process value overrange direction for when a sensor error occurs can be specified. (High: Set input range $+20^\circ\text{C}$ or $+20^\circ\text{F}$; low: Set input range -20°C or -20°F) |
| Function | Process value alarm | Process value 2-point alarm (HH, H, LL, L), alarm hysteresis, and ON-delay timer (0 to 60 s) are available. External alarm outputs: One per input (H or L). |
| | External alarm outputs | NPN outputs (with short-circuit protection) External power supply voltage: 20.4 to 26.4 V DC Max. switching capacity: 100 mA (for one output) Leakage current: 0.3 mA max. Residual voltage: 3 V max. |
| Isolation | | Between inputs and PLC signal: Transformer for power supply and photocoupler for signals Between each input: Transformer for power supply and photocoupler for signals. |
| Insulation resistance | | 20 M Ω max. (at 500 V DC). Between all output and NC terminals and external AC terminals (Power Supply Unit) Between all input terminals and external AC terminals (Power Supply Unit) Between all input terminals and all output terminals Between all external DC terminals (input, output, and NC terminals) and FG plate Between all input and output terminals and all NC terminals |

| Item | Specifications |
|---|---|
| Dielectric strength | Between all output and NC terminals and external AC terminals (Power Supply Unit) 2,000 VAC, 50/60 Hz 1 min., detection current: 1 mA Between all input terminals and external AC terminals (Power Supply Unit) Between all input terminals and all output terminals Between all external DC terminals (input, output, and NC terminals) and FG plate 1,000 VAC, 50/60 Hz 1 min., detection current: 1 mA Between all channels 500 VAC, 50/60 Hz 1 min., detection current: 1 mA |
| External connections | Terminal block (detachable) |
| Unit number settings | Set by rotary switches on front panel, from 0 to 95. |
| Indicators | Seven LED indicators on front panel (for normal operation, errors detected at the Thermocouple Input Unit, errors related to the CPU Unit, and four indicators for external alarm outputs.) |
| Effect on CPU Unit cycle time | 0.4 ms |
| Current consumption (supplied from Power Supply Unit) | 5 V DC at 250 mA max. |
| Dimensions | 31 × 90 × 65 mm (W × H × D) |
| Weight | 150 g max. |

Sensor Type and Input Range

The Temperature Sensor type and input range are set in the allocated words in the DM Area for every four inputs.

The measurable data range is ± 20 digits wider than the sensor input range.

| Set-ting | Input | °C | | | | °F | | | |
|----------|---------------------------------------|---|---|------------------------------------|---|---|---|--|--|
| | | 16-bit binary | BCD | | 16-bit binary | BCD | | | |
| | | | F□□□ indicates minus sign. | Leftmost bit indicates minus sign. | | F□□□ indicates minus sign. | Leftmost bit indicates minus sign. | | |
| 0 | K: -200 to 1300°C (-300 to 2300°F) | FF38 to FFFF to 0514 (-200 to -1 to 1300) | F200 to 1300 (-200 to 1300) | 8200 to 1300 (-200 to 1300) | FED4 to FFFF to 08FC (-300 to -1 to 2300) | F300 to 2300 (-300 to 2300) | F300 to 2300 (-300 to 2300) | | |
| 1 | K: 0.0 to 500°C (0.0 to 900.0°F) | 0000 to 1388 (0.0 to 500.0) | 0000 to 5000 (0.0 to 500.0) | 0000 to 5000 (0.0 to 500.0) | 0000 to 2328 (0.0 to 900.0) | 0000 to 9000 (0.0 to 900.0) | 0000 to 7999 (See note 3.) (0.0 to 799.9) | | |
| 2 | J: -100 to 850°C (-100 to 1500°F) | FF9C to FFFF to 0352 (-100 to -1 to 850) | F100 to 0850 (-100 to 850) | 8100 to 0850 (-100 to 850) | FF9C to FFFF to 05DC (-100 to -1 to 1500) | F100 to 1500 (-100 to 1500) | 8100 to 1500 (-100 to 1500) | | |
| 3 | J: 0.0 to 400.0°C (0.0 to 750.0°F) | 0000 to 0FA0 (0.0 to 400.0) | 0000 to 4000 (0.0 to 400.0) | 0000 to 4000 (0.0 to 400.0) | 0000 to 1D4C (0.0 to 750.0) | 0000 to 7500 (0.0 to 750.0) | 0000 to 7500 (0.0 to 750.0) | | |
| 4 | T: -200 to 400°C (-300 to 700.0°F) | F830 to FFFF to 0FA0 (-200.0 to -0.1 to 400.0) | F999 to 4000 (See note 3.) (-99.9 to 400.0) | A000 to 4000 (-200.0 to 400.0) | F448 to FFFF to 1B58 (-300.0 to -0.1 to 700.0) | F999 to 7000 (See note 3.) (-99.9 to 700.0) | B000 to 7000 (-300.0 to 700.0) | | |
| 5 | L: -100 to 850°C (-100 to 1500°F) | FF9C to FFFF to 0352 (-100 to -1 to 850) | F100 to 0850 (-100 to 850) | 8100 to 0850 (-100 to 850) | FF9C to FFFF to 05DC (-100 to -1 to 1500) | F100 to 1500 (-100 to 1500) | 8100 to 1500 (-100 to 1500) | | |
| 6 | L: 0.0 to 400.0°C (0.0 to 750.0°F) | 0000 to 0FA0 (0.0 to 400.0) | 0000 to 4000 (0.0 to 400.0) | 0000 to 4000 (0.0 to 400.0) | 0000 to 1D4C (0.0 to 750.0) | 0000 to 7500 (0.0 to 750.0) | 0000 to 7500 (0.0 to 750.0) | | |
| 7 | R: 0 to 1700°C (0 to 3000°F) | 0000 to 06A4 (0 to 1700) | 0000 to 1700 (0 to 1700) | 0000 to 1700 (0 to 1700) | 0000 to 0BB8 (0 to 3000) | 0000 to 3000 (0 to 3000) | 0000 to 3000 (0 to 3000) | | |

| Setting | Input | °C | | | °F | | |
|---------|--|-------------------------------|-------------------------------|------------------------------------|-------------------------------|-------------------------------|------------------------------------|
| | | 16-bit binary | BCD | | 16-bit binary | BCD | |
| | | | F□□□ indicates minus sign. | Leftmost bit indicates minus sign. | | F□□□ indicates minus sign. | Leftmost bit indicates minus sign. |
| 8 | S: 0 to 1700°C (0 to 3000°F) | 0000 to 06A4 (0 to 1700) | 0000 to 1700 (0 to 1700) | 0000 to 1700 (0 to 1700) | 0000 to 0BB8 (0 to 3000) | 0000 to 3000 (0 to 3000) | 0000 to 3000 (0 to 3000) |
| 9 | B: 400 to 1800°C (See note 2.) (750 to 3200°F) | 0190 to 0708 (400 to 1800) | 0400 to 1800 (400 to 1800) | 0400 to 1800 (400 to 1800) | 02EE to 0C80 (750 to 3200) | 0750 to 3200 (750 to 3200) | 0750 to 3200 (750 to 3200) |

- Note**
- If the indication range is exceeded, a sensor error will occur and the sensor error bit will turn ON. The process value will be clamped at the lower or upper limit of the indication range, depending on the setting for data direction at sensor error.
 - The lower limit for B thermocouples is 0°C/°F.
 - The indicator range for BCD display will be clamped at the lower (or upper) limit in the region between the lower (or upper) limit of the setting range and the point where a sensor error occurs.
For 0.1°C/0.1°F indication with minus sign indicated by leftmost 4 bits (bits 12 to 15): Lower limit = -99.9, Upper limit = 999.9.
For 0.1°C/0.1°F indication with minus sign indicated by leftmost bit (bit 15): Lower limit = -799.9, Upper limit = 799.9.

Temperature Characteristics According to Thermocouple Type

| Thermocouple | Temperature range | Set value error when ambient temperature changes by 1°C |
|--------------|-------------------|---|
| R | 0 to 200 °C | ±0.43°C |
| | 200 to 1,000°C | ±0.29°C |
| | 1,000 to 1,700°C | ±285 ppm of PV |
| S | 0 to 200 °C | ±0.43°C |
| | 200 to 1,000°C | ±0.29°C |
| | 1,000 to 1,700°C | 285 ppm of PV |
| B | 400°C or less | Not specified. |
| | 400 to 800°C | ±0.43°C |
| | 800 to 1,000°C | ±0.29°C |
| | 1,000 to 1,800°C | 285 ppm of PV |
| K | -200 to -100°C | ±0.29°C |
| | -100 to 400°C | ±0.11°C |
| | 400 to 1,300°C | ±285 ppm of PV |
| J | -100 to 400°C | ±0.11°C |
| | 400 to 850°C | ±285 ppm of PV |
| T | -200 to -100°C | ±0.29°C |
| | -100 to 400°C | ±0.11°C |
| L | -100 to 400°C | ±0.11°C |
| | 400 to 850°C | ±285 ppm of PV |

The measured temperature error is calculated as shown in the following example.

| Item | Details |
|---------------------------|---------|
| Ambient temperature | 30°C |
| Thermocouple type | K |
| Measured temperature (PV) | 500°C |

| Item | Details |
|-------------------------------|---|
| Reference accuracy (25°C) | ±0.3°C of PV or ±1°C, whichever is greater, ±1 digit. In this example, ±1.5°C. |
| Temperature characteristics | 400 to 1,300°C: 285 ppm of PV. In this example, 285 ppm × 500°C = 0.143°C. |
| Change in ambient temperature | 5°C (25 to 30°C). |

Overall accuracy =

Reference accuracy + Temperature characteristic × Change in ambient temperature = ±1.5°C + ±0.143°C × 5 = Approx. ±2.2°C ±1 digit.

DM Area Allocations

First word: m = D20000 + unit number × 100 (unit number: 0 to 95)

| DM Area address | | | | Data range | | Default | Data contents |
|--|-------------|-------------|-------------|-------------------------------|------------------|--|---|
| Input No. 1 | Input No. 2 | Input No. 3 | Input No. 4 | Decimal | Hexadecimal | | |
| m | | | | 12345, 0 | 3039, 0000 hex | 0000 hex | Default block read command Specifies the direction of data transfer when the PLC is turned ON or the Unit is restarted for DM words m+1 to m+31. <ul style="list-style-type: none"> 12345 (3039 hex): The data in words m+1 to m+31 is transferred from the Thermocouple Input Unit to the CPU Unit. When the transfer is completed, the value will become 0000 hex. Other than 12345 (3039 hex) (such as 0000 hex): The data in the allocated words of DM Area is transferred from the CPU Unit to the Thermocouple Input Unit. |
| Display parameter | | | | | | | |
| m + 1 | | | | 0 to 34 | 0000 to 0022 hex | 0 (0000 hex) | Address of Data Range Error (See note 1.) |
| Setting Group 1 (continuously refreshed area): Parameters that are continuously refreshed during PLC operation (regardless of the CPU Unit's operation mode) | | | | | | | |
| | | | | | | Process value alarm settings | |
| m + 2 | m + 6 | m + 10 | m + 14 | Low to high limit for sensors | 1300 (0514 hex) | Process value H (high limit) alarm setting | |
| m + 3 | m + 7 | m + 11 | m + 15 | | -200 (FF38 hex) | Process value L (low limit) alarm setting | |
| | | | | | | Span adjustment value | |
| m + 4 | m + 8 | m + 12 | m + 16 | 0 to 9999 | 0000 to 270F hex | 1000 (03E8 hex) | m+32 contains 0: Set value × 0.001 |
| | | | | 0 to 32000 | 0000 to 7D00 hex | 10000 (2710 hex) | m+32 contains 1: Set value × 0.0001 |
| | | | | | | Zero adjustment value | |
| m + 5 | m + 9 | m + 13 | m + 17 | -9999 to 9999 | D8F1 to 270F hex | 0 (0000 hex) | Set value × 0.1 |
| Setting Group 2 (initial settings area): Parameters that are transferred one time from the CPU Unit to the Thermocouple Input Unit if word m contains other than 12345 when the PLC is turned ON or the Thermocouple Input Unit is restarted. | | | | | | | |
| | | | | | | Operation settings (See note 2.) | |
| m + 18 | | | | (See note 2.) | (See note 2.) | 0 (0000 hex) | 00 to 03: Temperature unit (°C or °F) 04 to 07: Data display (binary or BCD) 08 to 11: Minus sign display format for BCD display 12 to 15: Data direction at sensor error |
| | | | | | | Sensor type | |
| m + 19 | | | | 0 to 9 | 0000 to 0009 hex | 0 (0000 hex) | 0: K, 1: K (with decimal point), 2: J, 3: J (with decimal point), 4: T, 5: L, 6: L (with decimal point), 7: R, 8: S, 9: B |

| DM Area address | | | | Data range | | Default | Data contents |
|-----------------------------------|----------------|----------------|----------------|------------|---------------------|--------------------|--|
| Input No. 1 | Input No. 2 | Input No. 3 | Input No. 4 | Decimal | Hexadecimal | | |
| External alarm output mode | | | | | | | |
| m + 20 | m + 23 | m + 26 | m + 29 | 0, 1 | 0000, 0001 hex | 0 (0000 hex) | Select either high limit or low limit alarm output. 0: High limit alarm; 1: Low limit alarm |
| Alarm hysteresis | | | | | | | |
| m + 21 | m + 24 | m + 27 | m + 30 | 0 to 9999 | 0000 to 270F hex | 0 (0000 hex) | set value × 0.1 |
| Alarm ON-delay time | | | | | | | |
| m + 22 | m + 25 | m + 28 | m + 31 | 0 to 60 | 0000 to 003C hex | 0 (0000 hex) | Unit: s |
| m+32 | | | | 0, 1 | 0000, 0001 hex | 1 (See note 3.) | Span adjustment mode 0: 1/1,000 1: 1/10,000 |

- Note**
- The ERC indicator on the Unit's front panel will light if an out-of-range setting is made in either Setting Group 1 (continuously refreshed area) or 2 (initial settings area). The offset from word m to the first word containing the out-of-range error will be stored as the Address of Data Range Error in the DM Area in four digits hexadecimal.
 - The operation settings are shown in the following table.

| Word | Bits | Description | Settings |
|------|------|---|---|
| m+18 | 00 | Temperature unit setting | 0: °C 1: °F |
| | 04 | Data format | 0: Binary (Negative values are given as 2's complements). 1: BCD |
| | 08 | Minus sign display format for BCD display | 0: "F" used to indicate the minus sign. 1: Leftmost bit used to indicate the minus sign. The setting is disabled if bits 04 to 07 are set to 0. |
| | 12 | Data direction at sensor error | 0: Goes to upper limit at sensor error 1: Goes to lower limit at sensor error |

Example: For a temperature in degrees Celsius (°C), a binary data format, and a data direction at sensor error of "lower limit," word m+18 contains 1000.

- Indicates the value after transferring the default value (set when 12345 is written to word m).

CIO Area AllocationsFirst word: $n = 2000 + \text{unit number} \times 10$ (unit number: 0 to 95)

| Direction | Word | Bit | Name | | Data range | Contents | |
|-------------------------------------|-----------|--|----------------------------|------------------------------------|-------------------------------------|--|---|
| Thermocouple Input Unit to CPU Unit | n | 00 | Input No. 1 | Process value L (low limit) alarm | 0, 1 | 0: Process value > Set value 1: Process value ≤ Set value | |
| | | 01 | | Process value H (high limit) alarm | 0, 1 | 0: Process value < Set value 1: Process value ≥ Set value | |
| | | 02 | Input No. 2 | Process value L (low limit) alarm | 0, 1 | Same as for input No. 1. | |
| | | 03 | | Process value H (high limit) alarm | 0, 1 | | |
| | | 04 | Input No. 3 | Process value L (low limit) alarm | 0, 1 | | |
| | | 05 | | Process value H (high limit) alarm | 0, 1 | | |
| | | 06 | Input No. 4 | Process value L (low limit) alarm | 0, 1 | | |
| | | 07 | | Process value H (high limit) alarm | 0, 1 | | |
| | 08 to 15 | Not used. | | | | | |
| | n + 1 | 00 to 15 | Input No. 1 | Process value | Depends on type of input. | | Stores data in the data range specified for each input type ±20 digits. |
| | n + 2 | 00 to 15 | Input No. 2 | | | | |
| | n + 3 | 00 to 15 | Input No. 3 | | | | |
| | n + 4 | 00 to 15 | Input No. 4 | | | | |
| Thermocouple Input Unit to CPU Unit | n + 5 | 00 to 15 | Not used. | | | | |
| | n + 6 | 00 to 15 | Not used. | | | | |
| | n + 7 | 00 to 15 | Not used. | | | | |
| | n + 8 | 00 to 15 | Not used. | | | | |
| | n + 9 | 00 | Input No. 1 | Sensor error | 0, 1 | 0: Normal 1: Error | |
| | | 01 | Input No. 2 | | 0, 1 | | |
| | | 02 | Input No. 3 | | 0, 1 | | |
| | | 03 | Input No. 4 | | 0, 1 | | |
| | 04 to 07 | Not used. | | | | | |
| | 08 | | Cold junction sensor error | | 0, 1 | 0: Normal 1: Error | |
| 09 to 14 | Not used. | | | | | | |
| 15 | | Conversion data enabled flag (See note.) | | 0, 1 | 0: Data disabled 1: Data enabled | | |

Note The Conversion Data Enabled Flag remains OFF after the PLC is turned ON or the Unit is restarted until the AD conversion data becomes stable (approximately 2 to 4 s), then is ON during operation.

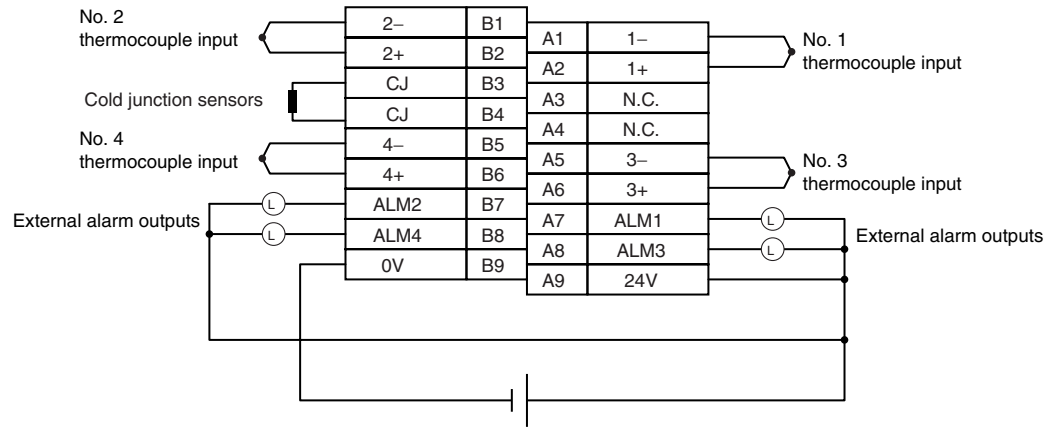
Terminal Connection Diagram**Note** Action for Unused Input Terminals

- Short-circuit the positive (+) and negative (-) sides of the thermocouple input section using a lead wire. For example, short terminals A3 and A2 for No. 1 thermocouple input.
- Cold junction sensors are mounted before shipment. If one of the cold junction sensors is disconnected, cold junction compensation will stop and correct measurement of temperatures cannot be made. Always make sure the cold junction sensors are connected when using the Units.
- Cold junction sensors are calibrated separately for each Unit and connected circuit, so correct temperatures will not be measured if a cold junction sensor from another Unit is used or if the two cold junction sensors in a Unit are swapped. Use the cold junction sensors as they are provided, without making any changes.
- Do not connect anything to NC terminals. Do not use NC terminals as relay terminals.
- Always ground the GR terminal on the Power Supply Unit of the PLC.
- If the input device uses a voltage generator, temperature compensator, or similar device, then ground the input device if it has a ground terminal.

Terminal Block Diagram

■ **Input Circuit**

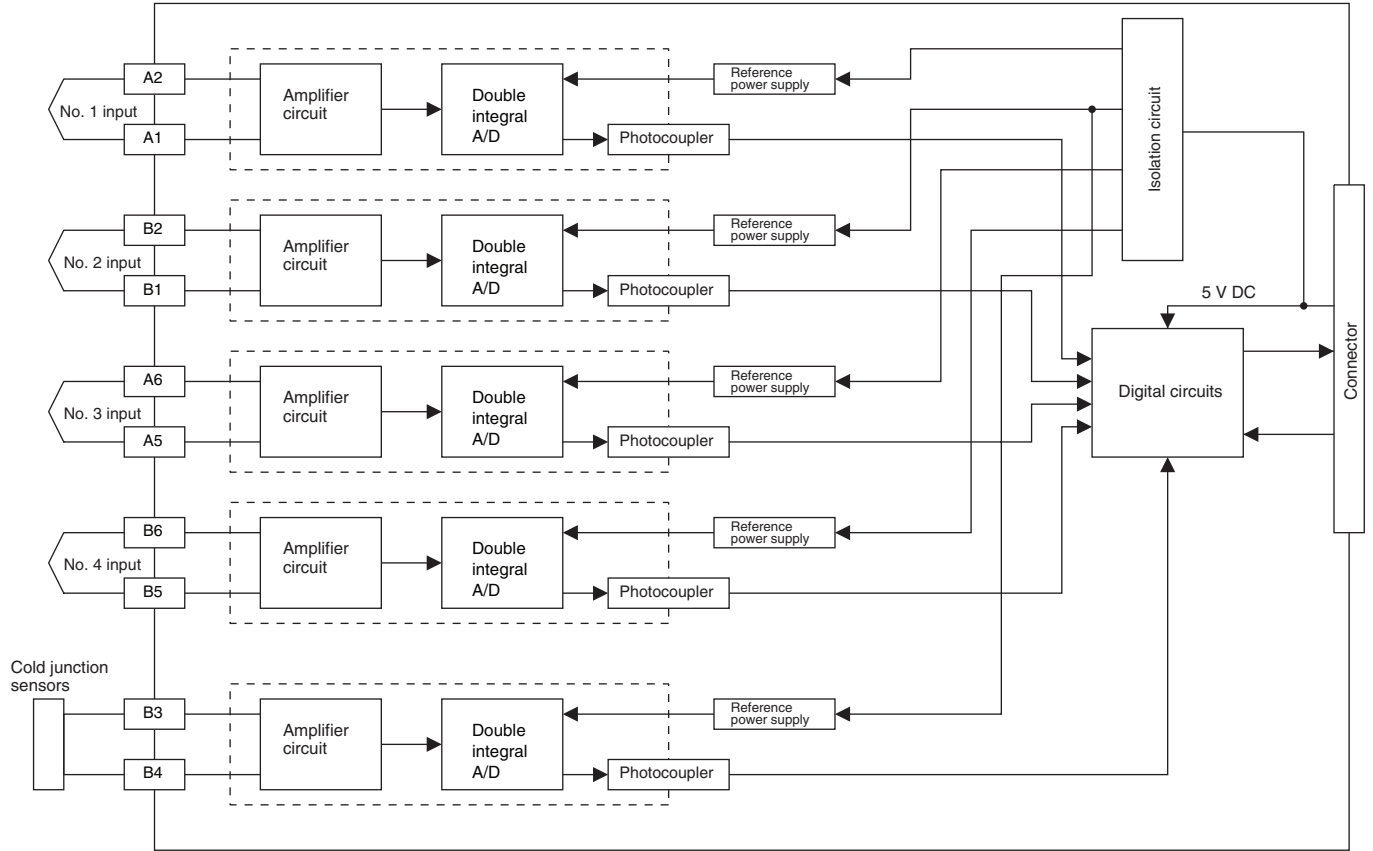

■ **Output Circuit**

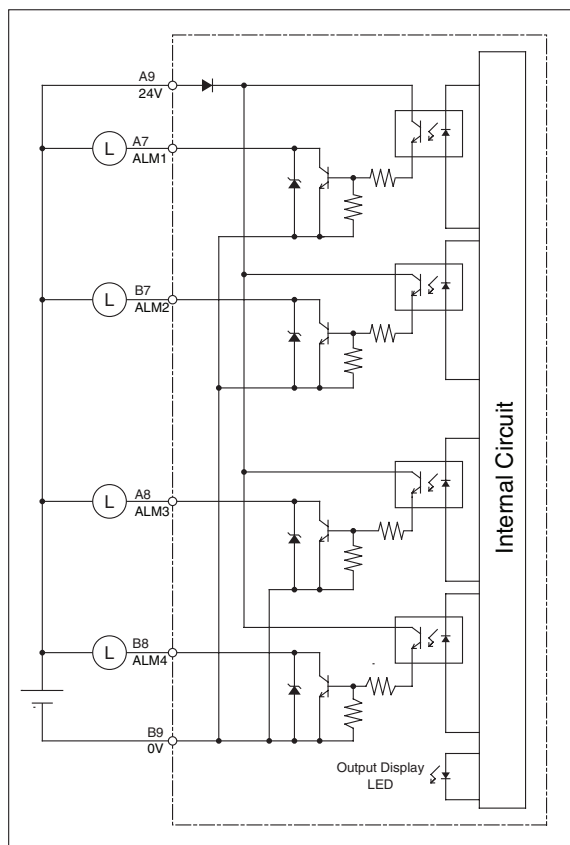

Error Processing

Conversion Data Does Not Change.

| Probable cause | Remedy |
|---|--|
| The gain for span adjustment is set to 0. | Set the gain for span adjustment to a value other than 0. |
| The sensor type is not set correctly. | Check and correct the settings. |
| An input device is malfunctioning, input wiring is faulty, or wiring is disconnected. | Check whether the input voltage or current has changed. Check for faulty or disconnected wiring. Check whether a sensor error has been detected in the I/O Area. |

Values are Not Converted as Intended.

| Probable cause | Remedy |
|---|--|
| The sensor type is not set correctly. | Check and correct the settings. |
| The zero/span adjustment data is incorrect. | Check and correct the zero/span adjustment settings. |

| Probable cause | Remedy |
|--|---|
| Cold junction compensation is not operating. | Check the Cold Junction Error Flag. |
| A compensation conductor has not been used or a different compensation conductor is used. | Use the correct compensation conductor for the thermocouple. |
| Incorrect input wiring (incorrect thermocouple or compensation conductor polarity.) | Correct the input wiring. |
| Thermocouple lead or compensating conductor is too long and measurements are being affected by conductor resistance. | Use a thicker compensating conductor. Change the wiring position and shorten the compensating conductor. |
| The terminal block temperature is not uniform due to radiated heat from peripheral devices. | Mount the unit in a position unaffected by radiated heat. |

Converted Values are Unstable.

| Probable cause | Remedy |
|---|---|
| Input signals are being affected by external noise. | Change the connection paths of the input signal lines. (Separate them from sources of noise or use shielded cable.) |
| | Insert a 0.01 to 0.1 μ F ceramic capacitor between the positive (+) and negative (-) input terminals. |
| An airflow is hitting the Unit terminal block. | Move the terminal block to a position unaffected by airflow. |

3-2 CJ1W-PTS15 Isolated-type Thermocouple Input Unit

Overview

The CJ1W-PTS15 Isolated-type Thermocouple Input Unit provides two direct thermocouple inputs, and sends the data to the CPU Unit each cycle. All inputs are isolated.

CJ1W-PTS15

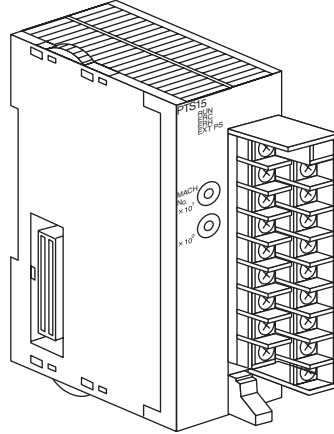

System Configuration

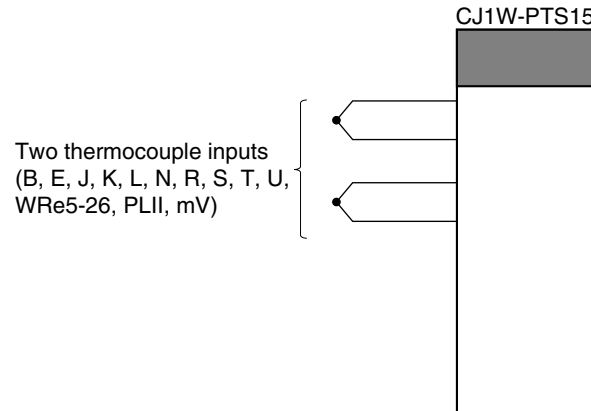

Features

- Up to two Thermocouples can be connected for each Unit. (The temperature sensor and input range settings can be made separately for each of the two inputs.)
- There is isolation between channels, so unwanted circuit paths between thermocouple inputs can be prevented.
- A variety of temperature specifications are supported. Any of the following can be selected for thermocouple input: B, E, J, K, L, N, R, S, T, U, WRe5-26, PLII, mV.
- 1/64,000 resolution for all temperature specifications.
- High-speed conversion of 10 ms/2 inputs.
- Temperature sensor values are transmitted to the CPU Unit in four digits hexadecimal.
- Variable input range setting (input range set by user).
- Four values for each process value alarm input.
- Alarm ON-delay timer for process value
- Mean value processing.
- Rate-of-change calculation.

- Two values for each rate-of-change alarm input.
- Zero/span adjustment capability during operation.
- Disconnection detection.
- Maximum or minimum process value can be specified for when a disconnection is detected.
- Adjustment period control.
- Peak and bottom detection.
- Top and valley detection.

Model Information

| Unit classification | Model number | Inputs | Input types |
|----------------------------|--------------|--------|--|
| CJ-series Special I/O Unit | CJ1W-PTS15 | 2 | B, E, J, K, L, N, R, S, T, U, WRe5-26, PLII, or mV selectable for each input |

Block Diagram (Order of Processing)

CPU Unit

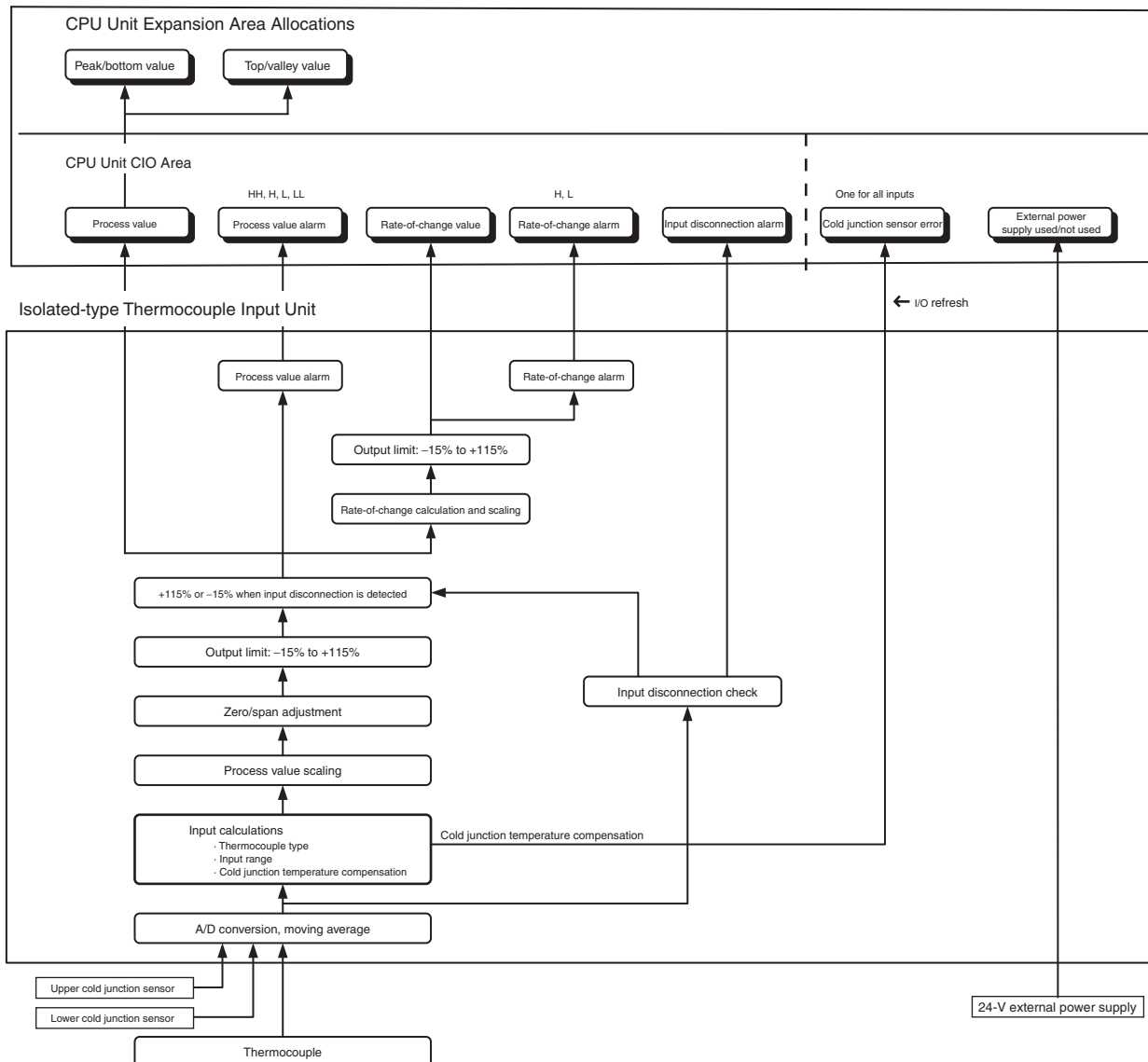

Specifications

| Item | | Specifications |
|--|--|--|
| Model | | CJ1W-PTS15 |
| Applicable PLC | | CJ Series |
| Unit classification | | CJ-series Special I/O Unit |
| Mounting position | | CJ-series CPU Rack or CJ-series Expansion Rack |
| Maximum number of Units | | 40 (within the allowable current consumption and power consumption range) |
| Unit numbers | | 00 to 95 (Cannot duplicate Special I/O Unit numbers.) |
| Areas for data exchange with CPU Unit | Special I/O Unit Area | 10 words/Unit Thermocouple Input Unit to CPU Unit: All process values, process value alarms (LL, L, H, HH), conversion data enabled flags, sensor errors. |
| | DM Area words allocated to Special I/O Units | 100 words/Unit CPU Unit to Thermocouple Input Unit: Temperature sensor type, input range (user set), process value alarm setting (L, H), zero/span adjustment value. |
| | Expansion Control/Monitor Area words | 35 words/Unit CPU Unit to Thermocouple Input Unit: Hold function selection start/reset, adjustment period control, control bits Thermocouple Input Unit to CPU Unit: Adjustment period warnings/notices (for each input), peak and bottom values, top and valley values |
| | Expansion Setting Area words | 46 words/Unit CPU Unit to Thermocouple Input Unit: Expansion Setting Area settings, adjustment period control, peak and bottom detection, top and valley detection |
| Number of temperature sensor inputs | | 2 |
| Temperature sensor type | | The sensor type, input range, and scaling can be set individually for each of 2 inputs, which are each selectable from B, E, J, K, L, N, R, S, T, U, WRe5-26, PL II, and mV. |
| Scaling | | Data to be stored in the allocated words in the CIO area must be scaled (with the minimum and maximum values set by user) (2 inputs set separately). For example, data can be stored at 0% to 100%. |
| Data storage in the CIO Area | | The value derived from carrying out the following processing in order of the actual process data in the input range is stored in four digits hexadecimal (binary values) in the allocated words in the CIO Area. 1) Mean value processing → 2) Scaling → 3) Zero/span adjustment → 4) Output limits |
| Accuracy (25°C) | | ±0.05% (Depends on the Sensor used and the measured temperature. Refer to <i>Accuracy by Sensor Type and Measured Temperature Range</i> on page 292 for details.) |
| Temperature coefficient | | ±0.01%/°C (For full scale of electromotive force. See note.) |
| Resolution | | 1/64000 |
| Cold junction compensation error | | ±1°C, at 20 ±10°C |
| Maximum signal input | | ±120 mV |
| Input impedance | | 20 kΩ min. |
| Input disconnection detection current | | 0.1 μA (typical) |
| Warmup time | | 45 min |
| Response time | | 100 ms (travel time from input 0% to 90%, for ±100 mV step input and with moving average for 4 samples) |
| Conversion period | | 10 ms/2 inputs |
| Maximum time to store data in CPU Unit | | Conversion period + one CPU Unit cycle |
| Disconnection detection | | Detects disconnections at each input and turns ON the Disconnection Detection Flag. Hardware detection time: Approx. 0.5 s max. The process value overrange direction for when a disconnection occurs can be specified. (High: 115% of set input range; low: -15% of set input range) |

| Item | | Specifications |
|-------------------------------|--------------------------------------|--|
| Function | Mean value processing (input filter) | Calculates the moving average for the specified number of process values (1 to 128), and stores that value in the CIO Area as the process value. |
| | Process value alarm | Process value 4-point alarm (LL, L, H, HH), alarm hysteresis, and ON-delay timer (0 to 60 s) are available. |
| | Rate-of-change calculation | Calculates the amount of change per comparison time interval (1 to 16 s). |
| | Rate-of-change alarm | Rate-of-change 2-point alarm (L, H), alarm hysteresis (shared with process value alarm), and ON-delay timer (0 to 60 s, shared with process value alarm) are available. |
| | Adjustment period control | When zero/span adjustment is executed, the date is internally recorded at the Unit. When the preset zero/span adjustment period and number of days notice have elapsed (allocated in Expansion Setting Area), this function turns ON a warning flag to give notice that it is time for readjustment. |
| | Peak and bottom detection | This function detects the maximum (peak) and minimum (bottom) analog input values, from when the Hold Start Bit (output) allocated to the Expansion Control/Monitor Area turns ON until it turns OFF, and stores them in the Expansion Control/Monitor Area. |
| | Top and valley detection | This function detects the top and valley values for analog inputs, from when the Hold Start Bit (output) allocated to the Expansion Control/Monitor Area turns ON until it turns OFF, and stores them in the Expansion Control/Monitor Area. |
| Isolation | | Between inputs and PLC signals, and between inputs: Isolation by transformer for power supply, and by photocoupler for signals. Cold junction compensation circuit: No isolation from input 2 |
| Insulation resistance | | 20 M Ω (at 500 V DC) between inputs |
| Dielectric strength | | Between inputs: 1,000 V AC, at 50/60 Hz, for 1 min, leakage current 10 mA max. |
| External connections | | Terminal block (detachable) |
| Unit number settings | | Set by rotary switches on front panel, from 0 to 95. |
| Indicators | | Four LED indicators on front panel (for normal operation, errors detected at the Thermocouple Input Unit, errors related to the CPU Unit, and use of external power supply). |
| Front panel connector | | Sensor input connector terminal block (detachable) |
| Effect on CPU Unit cycle time | | 0.3 ms |
| Current consumption | | 5 V DC at 180 mA max. |
| External power supply | | 24 VDC +10%/-15% 60 mA max., inrush current: 20 A for 1 ms max. (The external 24-VDC power supply must be isolated.) |
| Dimensions | | 31 × 90 × 65 mm (W × H × D) |
| Weight | | 150 g max. |
| Standard accessories | | Two cold junction sensors (installed in terminal block) |

Note The method for calculating the error in temperature measurements, including the temperature coefficient, is given below. The “full scale of electromotive force” is the difference between the high limit and low limit converted to electromotive force for each thermocouple.

Example

Ambient temperature: 30 °C
 Temperature Sensor: K thermocouple (–270 to 1,372 °C)
 Measured temperature: 500 °C

From electromotive force table

–270 °C: –6.458 mV
 1,372 °C: 54.86 mV
 Full scale: 61.344

Electromotive conversion of temperature coefficient:

$$61.344 \text{ mV} \times \pm 0.01\%/^{\circ}\text{C} = \pm 6.13 \text{ } \mu\text{V}/^{\circ}\text{C}$$

Error in electromotive force at 30°C:

$$\pm 6.13 \text{ } \mu\text{V}/^{\circ}\text{C} \times (30^{\circ}\text{C} - 25^{\circ}\text{C}) = 30.65 \text{ } \mu\text{V}/^{\circ}\text{C}$$

Temperature difference between measurement point and terminals on Unit (ambient temperature) (based on ambient temperature of 30 °C and Measured temperature of 500 °C):

$$470 \text{ }^{\circ}\text{C}$$

Electromotive force per °C at a measured temperature of 470 °C (from the electromotive force tables for a K thermocouple):

$$43 \text{ } \mu\text{V}/^{\circ}\text{C}$$

$$\text{Error in temperature coefficient: } \pm 30.65 \text{ } \mu\text{V} \div 43 \text{ } \mu\text{V}/^{\circ}\text{C} = \pm 0.7^{\circ}\text{C}$$

Error in measured temperature = Accuracy ± Error from temperature coefficient + Error in cold junction compensation = ±0.8°C + ±0.7°C + ±1.0°C = ±2.5°C

Sensor Type and Input Range

The Temperature Sensor type and input range are set in the allocated words in the DM Area for every four inputs. The input range can be set anywhere within the measurable input ranges shown in the following table. Accuracy and resolution, however, are not determined from the set input range, but rather from the measurable input range shown in the following table. Therefore, accuracy and resolution do not change even when a narrow input range is set.

| Sensor type | DM Area setting | Measurable input range |
|-------------|-----------------|------------------------|
| B | 0 | 0 to 1,820°C |
| E | 1 | -270 to 1,000°C |
| J | 2 | -210 to 1,200°C |
| K | 3 | -270 to 1,372°C |
| N | 4 | -270 to 1,300°C |
| R | 5 | -50 to 1,768°C |
| S | 6 | -50 to 1,768°C |
| T | 7 | -270 to 400°C |
| mV | 8 | -100 to 100 mV |
| L | 9 | -200 to 900°C |
| U | 10 | -200 to 600°C |
| WRe5-26 | 11 | 0 to 2,300°C |
| PLII | 12 | 0 to 1,300°C |

Accuracy by Sensor Type and Measured Temperature Range

| Sensor type | Temperature range | Standard accuracy | Details |
|-------------|-------------------|-------------------|---|
| B | 0 to 1,820°C | ±1.8°C (±0.1%) | 400 to 800°C: ±3°C Less than 400°C: Accuracy is not specified. |
| E | -270 to 1,000°C | ±0.6°C (±0.05%) | -250 to 200°C: ±1.2°C Less than -250°C: Accuracy is not specified. |
| J | -210 to 1,200°C | ±0.7°C (±0.05%) | |
| K | -270 to 1,372°C | ±0.8°C (±0.05%) | -250 to 200°C: ±2°C Less than -250°C: Accuracy is not specified. |
| N | -270 to 1,300°C | ±0.8°C (±0.05%) | -200 to 150°C: ±1.6°C Less than -200°C: Accuracy is not specified. |
| R | -50 to 1,769°C | ±1.8°C (±0.1%) | 0 to 100°C: ±2.5°C Less than 0°C: Accuracy is not specified. |
| S | -50 to 1,769°C | ±1.8°C (±0.1%) | 0 to 100°C: ±2.5°C Less than 0°C: 3.2°C |
| T | -270 to 400°C | ±0.35°C (±0.05%) | -180 to 0°C: ±0.7°C -200 to -180°C: ±1.3°C Less than -200°C: Accuracy is not specified. |

| Sensor type | Temperature range | Standard accuracy | Details |
|-------------|-------------------|-------------------|---|
| L | -200 to 900°C | ±0.5°C (±0.05%) | |
| U | -200 to 600°C | ±0.4°C (±0.05%) | -100 to 0°C: ±0.5°C Less than -100°C: ±0.7°C |
| WRe5-26 | 0 to 2,315°C | ±1.2°C (±0.05%) | More than 2,200°C: ±1.4°C |
| PLII | 0 to 1,395°C | ±0.7°C (±0.05%) | |

DM Area Allocations

First word: m = D20000 + unit number × 100 (unit number: 0 to 95)

| DM Area address | | Data range | | Default | Data contents |
|--|-------------|-----------------|------------------------------------|------------------|--|
| Input No. 1 | Input No. 2 | Decimal | Hexadecimal | | |
| m | | 12345, 0 | 3039, 0000 hex | 0000 hex | Default block read command Specifies the direction of data transfer when the PLC is turned ON or the Unit is restarted for DM words m+1 to m+93. <ul style="list-style-type: none"> 12345 (3039 hex): The data in words m+1 to m+93 is transferred from the Thermocouple Input Unit to the CPU Unit. When the transfer is completed, the value will become 0000 hex. Other than 12345 (3039 hex) (such as 0000 hex): The data in the allocated words of DM Area is transferred from the CPU Unit to the Thermocouple Input Unit. |
| m + 1 | | --- | --- | 0 (0000 hex) | Not used. |
| Setting Group 1 (continuously refreshed area): Parameters that are continuously refreshed during PLC operation (regardless of the CPU Unit's operation mode) | | | | | |
| | | | | | Process value alarm settings |
| m + 2 | m + 10 | -32768 to 32767 | 8000 to FFFF hex, 0000 to 7FFF hex | 4200 (1068 hex) | Process value HH (high high limit) alarm setting (Set at process value scaling value.) |
| m + 3 | m + 11 | -32768 to 32767 | 8000 to FFFF hex, 0000 to 7FFF hex | 4000 (0FA0 hex) | Process value H (high limit) alarm setting (Set at process value scaling value.) |
| m + 4 | m + 12 | -32768 to 32767 | 8000 to FFFF hex, 0000 to 7FFF hex | 0 (0000 hex) | Process value L (low limit) alarm setting (Set at process value scaling value.) |
| m + 5 | m + 13 | -32768 to 32767 | 8000 to FFFF hex, 0000 to 7FFF hex | -200 (FF38 hex) | Process value LL (low low limit) alarm setting (Set at process value scaling value.) |
| | | | | | Rate-of-change value alarm settings |
| m + 6 | m + 14 | -32768 to 32767 | 8000 to FFFF hex, 0000 to 7FFF hex | 4000 (0FA0 hex) | Rate-of-change value H (high limit) alarm setting (Set at rate-of-change scaling value.) |
| m + 7 | m + 15 | -32768 to 32767 | 8000 to FFFF hex, 0000 to 7FFF hex | 0 (0000 hex) | Rate-of-change value L (low limit) alarm setting (Set at rate-of-change scaling value.) |
| | | | | | Zero/span adjustment |
| m + 8 | m + 16 | 0 to 32000 | 0000 to 7D00 hex | 10000 (2710 hex) | Gain for span adjustment (set value × 0.0001%) |
| m + 9 | m + 17 | -32000 to 32000 | 8300 to FFFF hex, 0000 to 7D00 hex | 0 (0000 hex) | Zero adjustment value (Set at process value scaling value.) |
| Setting Group 2 (initial settings area): Parameters that are transferred one time from the CPU Unit to the Thermocouple Input Unit if word m contains other than 12345 when the PLC is turned ON or the Thermocouple Input Unit is restarted. | | | | | |
| m + 34 | m + 49 | 0 to 12 | 0000 to 000C hex | 0 (0000 hex) | Sensor type 0: B, 1: E, 2: J, 3: K, 4: N, 5: R, 6: S, 7: T, 8: mV, 9: L, 10: U, 11: Wre5-26, 12: PLII |
| | | | | | Process value input range settings |
| m + 35 | m + 50 | -32000 to 32000 | 8300 to FFFF hex, 0000 to 7D00 hex | 4000 (0FA0 hex) | Maximum input signal value (set value × 0.1°C/°F or mV) |
| m + 36 | m + 51 | -32000 to 32000 | 8300 to FFFF hex, 0000 to 7D00 hex | 0 (0000 hex) | Minimum input signal value (set value × 0.1°C/°F or mV) |
| m + 37 | m + 52 | 0, 1 | 0000, 0001 hex | 0 (0000 hex) | Unit 0: °C, 1: °F |

| DM Area address | | Data range | | Default | Data contents | |
|---|-------------|---------------------|------------------------------------|------------------|--|--|
| Input No. 1 | Input No. 2 | Decimal | Hexadecimal | | | |
| m + 38 | m + 53 | 0, 1 | 0000, 0001 hex | 0 (0000 hex) | Process value overrange direction at time of input disconnection 0: High; 1: Low | |
| Process value scaling | | | | | | |
| m + 39 | m + 54 | -32000 to 32000 | 8300 to FFFF hex, 0000 to 7D00 hex | 4000 (0FA0 hex) | Value stored for maximum value in range (span) | |
| m + 40 | m + 55 | -32000 to 32000 | 8300 to FFFF hex, 0000 to 7D00 hex | 0 (0000 hex) | Value stored for minimum value in range (zero) | |
| Alarm supplementary functions | | | | | | |
| m + 41 | m + 56 | 0 to 32000 | 0000 to 7D00 hex | 40 (0028 hex) | Alarm hysteresis (Set at process value scaling value. Shared with process value alarm and rate-of-change alarm.) | |
| m + 42 | m + 57 | 0 to 60 | 0000 to 003C hex | 0 (0000 hex) | Alarm ON-delay time (Unit: s) (Shared with process value alarm and rate-of-change alarm.) | |
| Rate-of-change function | | | | | | |
| m + 43 | m + 58 | -32000 to 32000 | 8300 to FFFF hex, 0000 to 7D00 hex | 4000 (0FA0 hex) | Rate-of-change range setting | Maximum rate-of-change value (Set value industrial unit; comparison time interval) |
| m + 44 | m + 59 | -32000 to 32000 | 8300 to FFFF hex, 0000 to 7D00 hex | -4000 (F060 hex) | | Minimum rate-of-change value (Set value industrial unit; comparison time interval) |
| m + 45 | m + 60 | 1 to 16 | 0001 to 0010 hex | 1 (0001 hex) | Rate-of-change comparison time interval (Unit: s) | |
| m + 46 | m + 61 | -32000 to 32000 | 8300 to FFFF hex, 0000 to 7D00 hex | 4000 (0FA0 hex) | Rate-of-change value scaling | Value stored for maximum value in range |
| m + 47 | m + 62 | -32000 to 32000 | 8300 to FFFF hex, 0000 to 7D00 hex | -4000 (F060 hex) | | Value stored for minimum value in range |
| Mean value processing function | | | | | | |
| m + 48 | m + 63 | 1 to 128 | 0001 to 0080 hex | 25 (0019 hex) | Number of process values for calculating moving average for mean value processing | |
| Display parameter | | | | | | |
| m + 94 | m + 95 | 0 to 99, 100 to 1XX | 0000 to 0063 hex, 0064 to 0XXX hex | 0 (0000 hex) | Address of Data Range Error (See note.) | |
| Expansion Setting Area allocations | | | | | | |
| m+98 | | 0 to 5 | 0000 to 0005 hex | --- | Expansion Setting Area allocations: 0: Not used; 1: DM; 2: CIO; 3: W; 4: H; 5: EM | |
| m+99 | | 0 to 32767 | 0000 to 7FFF hex | --- | Expansion Setting Area first word | |

- Note**
1. The ERC indicator on the Unit's front panel will light if an out-of-range setting is made in either Setting Group 1 (continuously refreshed area) or 2 (initial settings area), or in the Expansion Setting Area. The offset from word m to the first word containing the out-of-range error will be stored as the Address of Data Range Error in the DM Area in four digits hexadecimal. If the first memory address containing the out-of-range error is in the Expansion Setting Area, the Address of Data Range Error will be over +100 (or +100 if the first word in the Expansion Setting Area is an error.)
 2. When specifying an expansion setting area, be sure that it does not overlap with other areas that are being used. If areas overlap, the words that are allocated may be overwritten, resulting in unexpected operation.
 3. When specifying the first word in an expansion setting area, be sure that the end of the memory area is not exceeded.

Expansion Setting Area

First word: word o. (o = address specified in word m+99 in the area specified in word m+98 in the DM Area)

| DM Area address | | Data range | | Default | Data contents |
|---|--------------|-----------------|------------------------------------|------------------|--|
| Input No. 1 | Input No. 2 | Decimal | Hexadecimal | | |
| Setting Group 3 (initial settings area): Parameters that are transferred one time from the CPU Unit to the Thermocouple Input Unit if word m contains other than 12345, and if Expansion Setting Area settings are allocated, when the PLC is turned ON or the Thermocouple Input Unit is restarted. | | | | | |
| | | | | | Expansion Control/Monitor Area settings |
| o | | 0 to 5 | 0000 to 0005 hex | --- | Expansion Control/Monitor Area allocation 0: Not used. 1: DM; 2: CIO; 3: W; 4: H; 5: EM |
| o+1 | | 0 to 32767 | 0000 to 7FFF hex | --- | Expansion Control/Monitor Area first word |
| | | | | | Zero/span adjustment supplementary function |
| o+2 | o+13 | 0 to 32000 | 0000 to 7D00 hex | 10000 (2710 hex) | Span adjustment position (Input span percentage) |
| o+3 | o+14 | -32000 to 32000 | 8300 to FFFF hex, 0000 to 7D00 hex | 0 (0000 hex) | Zero adjustment position (Input span percentage) |
| o+4 | o+15 | 0 to 9999 | 0000 to 270F hex | 365 (016D hex) | Zero/span adjustment period (Unit: Days) |
| o+5 | o+16 | 0 to 9999 | 0000 to 270F hex | 30 (001E hex) | Notice of days remaining (Unit: Days) |
| | | | | | Not used. |
| o+6 to o+8 | o+17 to o+19 | --- | --- | 0 (0000 hex) | Not used. |
| | | | | | Top and valley hold |
| o+9 | o+20 | 0 to 32000 | 0000 to 7D00 hex | 40 (0028 hex) | Hysteresis |
| | | | | | Not used. |
| o+10 | o+21 | --- | --- | 0 (0000 hex) | Not used. |
| o+11 | o+22 | | | | |
| o+12 | o+23 | | | | |

- Note**
1. When specifying an expansion control/monitor area be sure that it does not overlap with other areas that are being used. If areas overlap, the words that are allocated may be overwritten, resulting in unexpected operation.
 2. When specifying the first word in an expansion control/monitor area be sure that the end of the memory area is not exceeded.

CIO Area AllocationsFirst word: $n = 2000 + \text{unit number} \times 10$ (unit number: 0 to 95)

| Direction | Word | Bit | Name | | Data range | Contents | |
|---|---------------|-----------|-------------------------------------|--|--|---|--|
| Thermocouple Input Unit to CPU Unit | n | 00 | Input No. 1 | Process value LL (low low limit) alarm | 0, 1 | 0: Process value > Set value 1: Process value ≤ Set value | |
| | | 01 | | Process value L (low limit) alarm | 0, 1 | | |
| | | 02 | | Process value H (high limit) alarm | 0, 1 | | 0: Process value < Set value 1: Process value ≥ Set value |
| | | 03 | | Process value HH (high high limit) alarm | 0, 1 | | |
| | | 04 | Input No. 2 | Process value LL (low low limit) alarm | 0, 1 | Same as for input No. 1. | |
| | | 05 | | Process value L (low limit) alarm | 0, 1 | | |
| | | 06 | | Process value H (high limit) alarm | 0, 1 | | |
| | | 07 | | Process value HH (high high limit) alarm | 0, 1 | | |
| | 08 to 15 | Not used. | | 0 | --- | | |
| | n + 1 | 00 to 15 | Input No. 1 process value | | -32768 to 32767 (8000 to FFFF hex, 0000 to 7FFF hex) | The present process value is stored according to the scal- ing set in the allocated words of the DM Area. | |
| | n + 2 | 00 to 15 | Input No. 2 process value | | -32768 to 32767 (8000 to FFFF hex, 0000 to 7FFF hex) | | |
| | n + 3, n+4 | --- | Not used. | | 0000 | ---- | |
| | n + 5 | 00 to 15 | Input No. 1 rate-of-change value | | -32768 to 32767 (8000 to FFFF hex, 0000 to 7FFF hex) | The process value rate of change is stored according to the scaling set in the allo- cated words of the DM Area. | |
| | n + 6 | 00 to 15 | Input No. 2 rate-of-change value | | -32768 to 32767 (8000 to FFFF hex, 0000 to 7FFF hex) | | |
| | n + 7, n+8 | --- | Not used. | | --- | --- | |

| Direction | Word | Bit | Name | | Data range | Contents |
|---|-------|----------|---------------------------------------|---|------------|--|
| Thermocouple Input Unit to CPU Unit | n + 9 | 00 | Input No. 1 | Rate-of-change value L (low limit) alarm | 0, 1 | 0: Rate-of-change value > Set value 1: Rate-of-change value ≤ Set value |
| | | 01 | | Rate-of-change value H (high limit) alarm | 0, 1 | 0: Rate-of-change value < Set value 1: Rate-of-change value ≥ Set value |
| | | 02 | Input No. 2 | Rate-of-change value L (low limit) alarm | 0, 1 | Same as for input No. 1. |
| | | 03 | | Rate-of-change value H (high limit) alarm | 0, 1 | |
| | | 04 to 07 | Not used. | | 0 | --- |
| | | 08 | Input No. 1 input disconnec- tion | | 0, 1 | 0: Normal 1: Disconnection |
| | | 09 | Input No. 2 input disconnec- tion | | 0, 1 | |
| | | 10, 11 | Not used. | | 0 | --- |
| | | 12 | Cold junction sensor error | | 0, 1 | 0: Normal 1: Error |
| | | 13 | Zero/span adjustment period end | | 0, 1 | 0: Adjustment enabled 1: Adjustment ended |
| | | 14 | Zero/span adjustment period notice | | 0, 1 | 0: Adjustment enabled 1: Notice period |
| | | 15 | External power supply | | 0, 1 | 0: External power supply not used 1: External power supply used |

Note The External Power Supply Flag turns ON after external power is supplied and the internal voltage stabilizes (which requires approximately 2 s). The indicator on the front of the Unit will turn ON as soon as external power is supplied.

Expansion Control/Monitor Area Allocations

First word: word p. (p = address specified in word o+1 in the area specified in word o in the Expansion Setting Area)

| Direction | Word | Bit | Name | Data range | Contents |
|-------------------------------------|--------|-----------|---|------------|---|
| CPU Unit to Thermocouple Input Unit | p | 00 to 15 | Not used. | Not used. | Not used. |
| | p+1 | 00 | Input No. 1 hold function selection | 0, 1 | 0: Peak and bottom 1: Top and valley |
| | | 01 | Input No. 2 hold function selection | | |
| | | 02 to 07 | Not used. | 0 | Not used. |
| | | 08 | Input No. 1 hold start | 0, 1 | 0: Do not hold. 1: Hold |
| | | 09 | Input No. 2 hold start | | |
| | | 10, 11 | Not used. | 0 | Not used. |
| | | 12 | Input No. 1 hold value reset | 0, 1 | 0: Normal operation 1: Reset hold value. |
| | | 13 | Input No. 2 hold value reset | | |
| | 14, 15 | Not used. | 0 | Not used. | |
| | p+2 | 00 | Input No. 1 zero/span adjustment update bit | 0, 1 | 0: Normal operation 1: Update adjustment date (Remains ON while writing external FROM.) |
| | | 01 | Input No. 2 zero/span adjustment update bit | | |
| | | 02 to 15 | Not used. | 0 | Not used. |

| Direction | Word | Bit | Name | | Data range | Contents |
|-------------------------------------|--------------|----------|--------------------------|---|---|---|
| Thermocouple Input Unit to CPU Unit | p+3 | 00 | Input No. 1 | Zero/span adjustment period end | 0, 1 | 0: Adjustment enabled. 1: Adjustment period end |
| | | 01 | | Zero/span adjustment period notice | 0, 1 | 0: Adjustment enabled. 1: Notice period in effect. |
| | | 02 | Input No. 2 | Zero/span adjustment period end | 0, 1 | Remains set to 1 if the zero/span adjustment bit has never been ON. |
| | | 03 | | Zero/span adjustment period notice | 0, 1 | |
| | | 04 to 07 | Not used. | | 0 | Not used. |
| | | 08 | External FROM Error Flag | | 0, 1 | 0: Normal operation 1: External FROM error |
| | | 09 to 15 | Not used. | | 0 | Not used. |
| | p+4 | 00 to 15 | Input No. 1 | Day of final adjustment date | 0100 to 3100 (BCD) | Remains set to FFFF if the zero/span adjustment bit has never been ON. |
| | p+5 | 00 to 15 | | Year and month of final adjustment date | 0001 to 9912 (BCD) | |
| | p+6 | 00 to 15 | Input No. 2 | Day of final adjustment date | 0100 to 3100 (BCD) | |
| | p+7 | 00 to 15 | | Year and month of final adjustment date | 0001 to 9912 (BCD) | |
| | p+8 to p+15 | --- | Not used. | | 0000 | Not used. |
| | p+16 | 00 to 15 | Input No. 1 | Peak/top value | -32728 to +32767 (8000 to FFFF hex, 0000 to 7FFF hex) | Counts the number of repetitions of conditional operations set in the Expansion Setting Area. |
| | p+17 | 00 to 15 | | Bottom/valley value | -32728 to +32767 (8000 to FFFF hex, 0000 to 7FFF hex) | The bottom or valley value is stored according to the scaling set in the DM Area. |
| | p+18 | 00 to 15 | Input No. 2 | Peak/top value | -32728 to +32767 (8000 to FFFF hex, 0000 to 7FFF hex) | Same as for Input No. 1. |
| | p+19 | 00 to 15 | | Bottom/valley value | -32728 to +32767 (8000 to FFFF hex, 0000 to 7FFF hex) | |
| | p+20 to p+34 | --- | Not used. | | 0000 | Not used. |

Terminal Connection Diagram

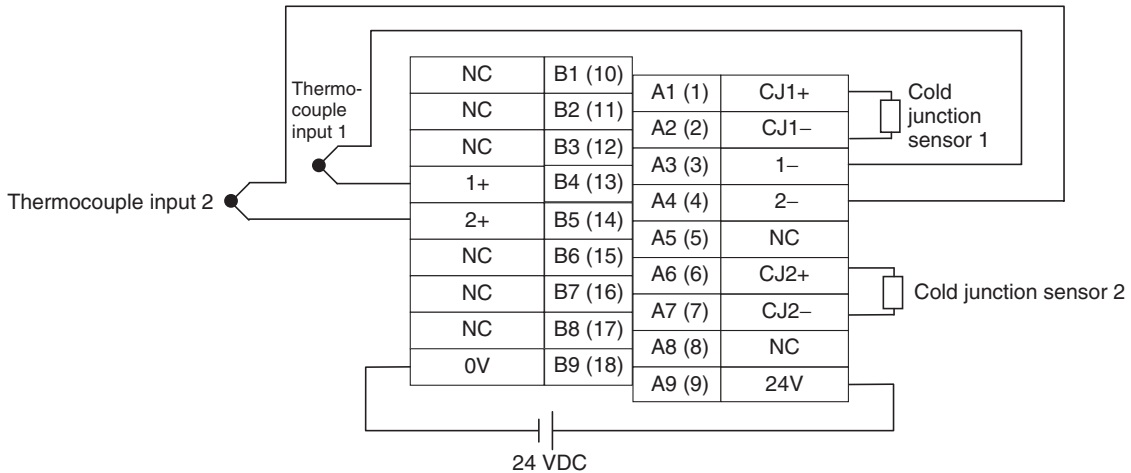

Note Action for Unused Input Terminals

- Short-circuit the positive (+) and negative (-) sides of the thermocouple input section using a lead wire. For example, short terminals A4 and B5 for No. 2 thermocouple input.
- Cold junction sensors are mounted between A1 and A2, and A6 and A7 before shipment. If one of the cold junction sensors is disconnected, cold junction compensation will stop and correct measurement of temperatures cannot be made. Always make sure the cold junction sensors are connected when using the Units.
- Cold junction sensors are calibrated separately for each Unit and connected circuit, so correct temperatures will not be measured if a cold junction sensor from another Unit is used or if the two cold junction sensors in a Unit are swapped. Use the cold junction sensors as they are provided, without making any changes.
- Always ground the GR terminal on the Power Supply Unit of the PLC.
- If the input device uses a voltage generator, temperature compensator, or similar device, then ground the input device if it has a ground terminal.

Terminal Block Diagram

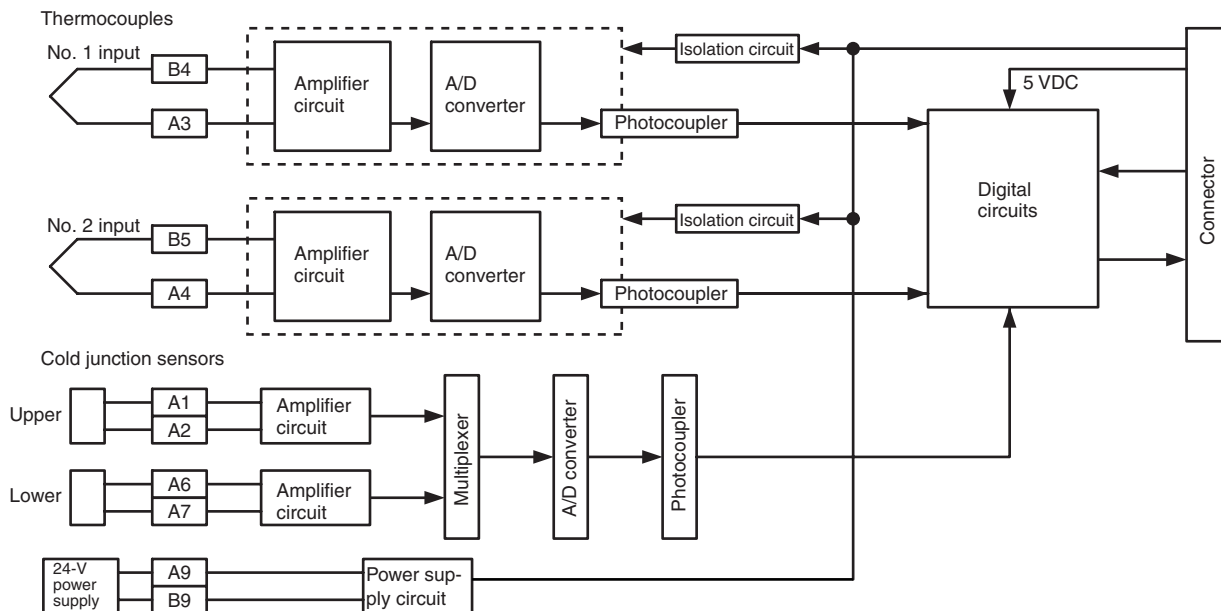

Error Processing**Conversion Data Does Not Change.**

| Probable cause | Remedy |
|--|--|
| The gain for span adjustment is set to 0. | Set the gain for span adjustment to a value other than 0. |
| The minimum and maximum values for process value scaling are either the same or are set extremely low. | Set the minimum and maximum values correctly. |
| The sensor type, input range, or process value scaling is not set correctly. | Check and correct the settings. |
| An input device is malfunctioning, input wiring is faulty, or wiring is disconnected. | Check whether the input voltage or current has changed. Check for faulty or disconnected wiring. Check whether a wiring disconnection has been detected in the I/O Area. |

Values are Not Converted as Intended.

| Probable cause | Remedy |
|---|--|
| The sensor type, input range, or process value scaling is not set correctly. | Check and correct the settings. |
| The zero/span adjustment data is incorrect. | Check and correct the zero/span adjustment settings. |
| Cold junction compensation is not operating. | Check the Cold Junction Error Flag. |
| A compensation conductor has not been used or a different compensation conductor is used. | Use the correct compensation conductor for the thermocouple. |
| Incorrect input wiring (incorrect thermocouple or compensation conductor polarity.) | Correct the input wiring. |

Converted Values are Unstable.

| Probable cause | Remedy |
|--|---|
| Input signals are being affected by external noise. | Change the connection paths of the input signal lines. (Separate them from sources of noise or use shielded cable.) |
| | Insert a 0.01 to 0.1 μ F ceramic capacitor between the positive (+) and negative (-) input terminals. |
| | Increase the number of values for calculating the moving average in mean value processing. |
| The process value scaling value is greater than the Unit's resolution. | Reduce the process value scaling value. |
| The input signal range setting is too small. | Match the input signal range to the internal ranges. |

3-3 CJ1W-PTS52 Isolated-type Resistance Thermometer Input Unit (Pt100, JPt100)

Overview

The CJ1W-PTS52 Isolated-type Resistance Thermometer Input Unit provides four direct platinum resistance thermometer inputs, and sends the data to the CPU Unit each cycle. All inputs are isolated.

CJ1W-PTS52

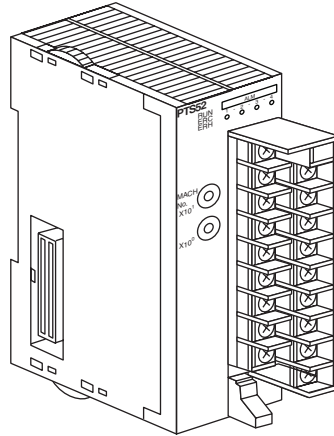

System Configuration

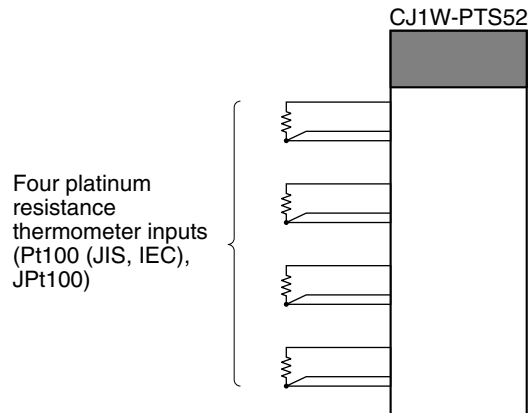

Features

- Up to four platinum resistance thermometers can be connected for each Unit. (The temperature sensor and input range settings are the same for all four inputs.)
- Pt100 (JIS, IEC), JPt100 can be selected.
- Temperature sensor values are transmitted to the CPU Unit in four digits hexadecimal. (Either binary or BCD data output can be selected.)
- Process value alarm (two alarms in internal memory and one external alarm output for each input).
- Alarm ON-delay timer and hysteresis for process value.
- Zero/span adjustment capability during operation.
- Sensor error detection.
- Maximum or minimum process value can be specified for when a sensor error is detected.

Model Information

| Unit classification | Model number | Inputs | Input types |
|----------------------------|--------------|--------|--|
| CJ-series Special I/O Unit | CJ1W-PTS52 | 4 | Platinum resistance thermometer Pt100 (JIS, IEC), JPt100 |

Block Diagram (Order of Processing)

The processing for the inputs is as shown in the following diagram.

CPU Unit

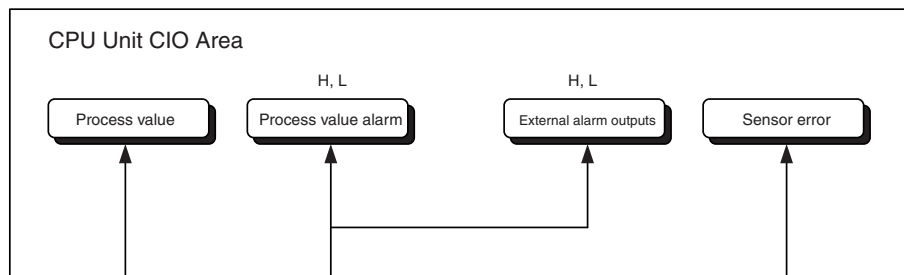

Isolated-type Resistance Thermometer Input Unit

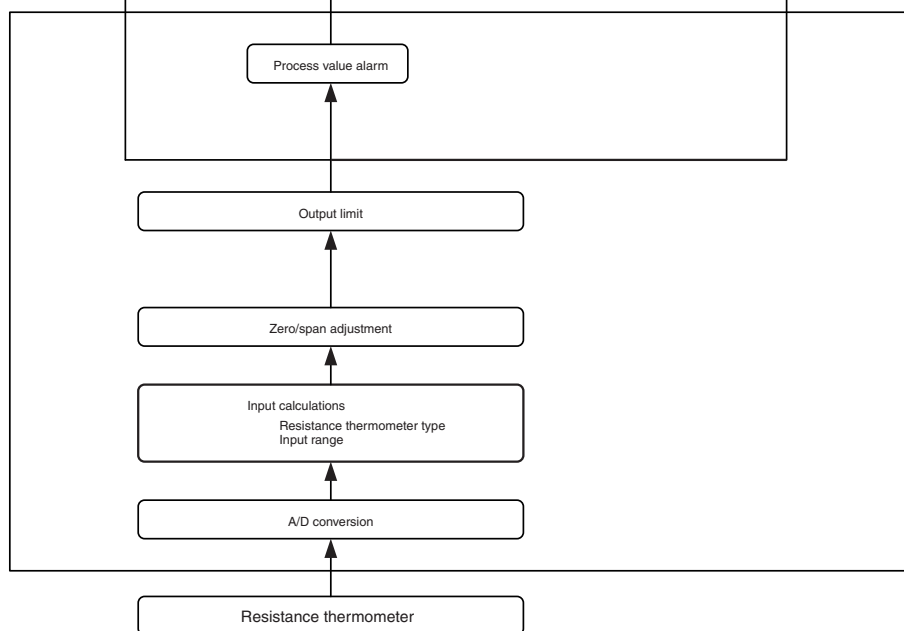

Specifications

| Item | Specifications |
|-------------------------|---|
| Model | CJ1W-PTS52 |
| Applicable PLC | CJ Series |
| Unit classification | CJ-series Special I/O Unit |
| Mounting position | CJ-series CPU Rack or CJ-series Expansion Rack |
| Maximum number of Units | 40 (within the allowable current consumption and power consumption range) |
| Unit numbers | 00 to 95 (Cannot duplicate Special I/O Unit numbers.) |

| Item | | Specifications |
|--|--|--|
| Areas for data exchange with CPU Unit | Special I/O Unit Area | 10 words/Unit Resistance Thermometer Input Unit to CPU Unit: All process values, process value alarms (L, H), conversion data enabled flags, sensor errors. |
| | DM Area words allocated to Special I/O Units | 100 words/Unit CPU Unit to Resistance Thermometer Input Unit: Temperature sensor type, input range (user set), process value alarm setting (L, H), zero/span adjustment value. |
| Number of temperature sensor inputs | | 4 |
| Temperature sensor type | | Pt100 (JIS, IEC), JPt100 Sensor type, input range, and scaling to industrial units are the same for all I/O. |
| Data storage in the CIO Area | | The actual process data in the input range is stored in four digits hexadecimal (binary or BCD values) in the allocated words in the CIO Area. |
| Accuracy (25°C) | | ±0.3% of PV or ±0.8°C, whichever is greater, ±1 digit max. ±0.3% of PV or ±1.6°F, whichever is greater, ±1 digit max. PV: Process value data |
| Temperature characteristics | | Refer to <i>Temperature Characteristics According to Platinum Resistance Thermometer Type</i> on page 305. |
| Sensing method | | 3-wire method |
| Influence of conductor resistance | | 0.4°C/Ω max. |
| Warmup time | | 10 min |
| Conversion period | | 250 ms/4 inputs |
| Maximum time to store data in CPU Unit | | Conversion period + one CPU Unit cycle |
| Sensor error detection | | Detects sensor error at each input and turns ON the Sensor error Flag. Hardware detection time: Approx. 0.5 s max. The process value overrange direction for when a sensor error occurs can be specified. (High: +20 digit of set input range; low: -20 digit of set input range) |
| Function | Process value alarm | Process value 2-point alarm (H, L), alarm hysteresis, and ON-delay timer (0 to 60 s are available). |
| | External alarm outputs | NPN outputs (with short-circuit protection) External power supply voltage: 20.4 to 26.4 V DC Max. switching capacity: 100 mA (for one output) Leakage current: 0.3 mA max. Residual voltage: 3 V max. |
| Isolation | | Between inputs and PLC signal: Transformer for power supply and photocoupler for signals Between each input: Transformer for power supply and photocoupler for signals |
| Insulation resistance | | 20 MΩ max. (at 500 V DC). Between all output and NC terminals and external AC terminals (Power Supply Unit) Between all input terminals and external AC terminals (Power Supply Unit) Between all input terminals and all output terminals Between all external DC terminals (input, output, and NC terminals) and FG plate Between all input and output terminals and all NC terminals |
| Dielectric strength | | Between all output and NC terminals and external AC terminals (Power Supply Unit) 2,000 V AC, 50/60 Hz 1 min., detection current: 1 mA Between all input terminals and external AC terminals (Power Supply Unit) Between all input terminals and all output terminals Between all external DC terminals (input, output, and NC terminals) and FG plate 1,000 V AC, 50/60 Hz 1 min., detection current: 1 mA Between all channels 500 V AC, 50/60 Hz 1 min., detection current: 1 mA |
| External connections | | Terminal block (detachable) |

| Item | Specifications |
|-------------------------------|--|
| Unit number settings | Set by rotary switches on front panel, from 0 to 95. |
| Indicators | Seven LED indicators on front panel (for normal operation, errors detected at the Resistance Thermometer Input Unit, errors detected at the CPU Unit, and four indicators for external alarm outputs.) |
| Effect on CPU Unit cycle time | 0.4 ms |
| Current consumption | 5 V DC at 250 mA max |
| Dimensions | 31 × 90 × 65 mm (W × H × D) Note The height including the Backplane is 145 mm. |
| Weight | 150 g max. |

Sensor Type and Input Range

The Platinum Resistance Thermometer type and input range are set in the allocated words in the DM Area for every four inputs.

The measurable data range is ±20 digits wider than the sensor input range.

| Setting | Input | °C | | | °F | | |
|---------|---|---|---|------------------------------------|--|--|--|
| | | 16-bit binary | BCD | | 16-bit binary | BCD | |
| | | | F□□□ indicates minus sign. | Leftmost bit indicates minus sign. | | Leftmost 4 bits (bits 15 to 12) indicate minus sign. | Leftmost bit (bit 15) indicates minus sign. |
| 0 | Pt100: -200.0 to 650.0°C (-300.0 to 1200.0°F) | F830 to FFFF to 1964 (-200.0 to -0.1 to 650.0) | F999 to 6500 (See note 2.) (-99.9 to 650.0) | A000 to 6500 (-200.0 to 650.0) | F448 to FFFF to 2EE0 (-300.0 to -0.1 to 1200.0) | F999 to 9999 (See note 2.) (-99.9 to 999.9) | B000 to 7999 (See note 2.) (-300.0 to 799.9) |
| 1 | JPt100: -200.0 to 650.0°C (-300.0 to 1200.0°F) | F830 to FFFF to 1964 (-200.0 to -0.1 to 650.0) | F999 to 6500 (See note 2.) (-99.9 to 650.0) | A000 to 6500 (-200.0 to 650.0) | F448 to FFFF to 2EE0 (-300.0 to -0.1 to 1200.0) | F999 to 9999 (See note 2.) (-99.9 to 999.9) | B000 to 7999 (See note 2.) (-300.0 to 799.9) |
| 2 to 9 | Do not set. | | | | Do not set. | | |

- Note**
- If the indication range is exceeded, a sensor error will occur and the sensor error bit will turn ON. The process value will be clamped at the lower or upper limit of the indication range, depending on the setting for data direction at sensor error.
 - The indicator range for BCD display will be clamped at the lower (or upper) limit in the region between the lower (or upper) limit of the setting range and the point where a sensor error occurs.
For 0.1°C/0.1°F indication with minus sign indicated by leftmost 4 bits (bits 12 to 15): Lower limit = -99.9, Upper limit = 999.9.
For 0.1°C/0.1°F indication with minus sign indicated by leftmost bit (bit 15): Lower limit = -799.9, Upper limit = 799.9.

Temperature Characteristics According to Platinum Resistance Thermometer Type

| Platinum Resistance Thermometer | Temperature range | Set value error when ambient temperature changes by 1°C |
|---------------------------------|-------------------|---|
| Pt100 | -200 to 200°C | ±0.06°C |
| | 200 to 650°C | 285 ppm of PV |
| JPt100 | -200 to 200°C | ±0.06°C |
| | 200 to 650°C | 285 ppm of PV |

The measured temperature error is calculated as shown in the following example.

| Item | Details |
|---------------------------------|---|
| Ambient temperature | 30°C |
| Platinum Resistance Thermometer | Pt100 |
| Measured temperature (PV) | 500°C |
| Reference accuracy (25°C) | ±0.3°C of PV or ±0.8°C, whichever is greater, ±1 digit. In this example, ±1.5°C. |
| Temperature characteristics | 200 to 650°C: 285 ppm of PV. In this example, 285 ppm × 500°C = 0.143°C. |
| Change in ambient temperature | 5°C (25 to 30°C) |

Overall accuracy =
 Reference accuracy + Temperature characteristic × Change in ambient temperature = ±1.5°C + ±0.143°C × 5 = Approx. ±2.2°C ±1 digit.

DM Area Allocations

First word: word m. m = D20000 + unit number × 100 (unit number: 0 to 95)

| DM Area address | | | | Data range | | Default | Data contents |
|--|-------------|-------------|-------------|-----------------------------------|------------------|--|---|
| Input No. 1 | Input No. 2 | Input No. 3 | Input No. 4 | Decimal | Hexadecimal | | |
| m | | | | 12345, 0 | 3039, 0000 hex | 0000 hex | Default block read command Specifies the direction of data transfer when the PLC is turned ON or the Unit is restarted for DM Area words m+1 to m+31. <ul style="list-style-type: none"> 12345 (3039 hex): The data in words m+1 to m+31 is transferred from the Resistance Thermometer Input Unit to the CPU Unit. When the transfer is completed, the value will become 0000 hex. Other than 12345 (3039 hex) (such as 0000 hex): The data in the allocated words of DM Area is transferred from the CPU Unit to the Resistance Thermometer Input Unit. |
| Display parameter | | | | | | | |
| m + 1 | | | | 0 to 31 | 0000 to 001F hex | 0 (0000 hex) | Address of Data Range Error (See note 1.) |
| Setting Group 1 (continuously refreshed area): Parameters that are continuously refreshed during PLC operation (regardless of the CPU Unit's operation mode) | | | | | | | |
| | | | | | | | Process value alarm settings |
| m + 2 | m + 6 | m + 10 | m + 14 | Low to high limit for all sensors | 6500 (1964 hex) | Process value H (high limit) alarm setting | |
| m + 3 | m + 7 | m + 11 | m + 15 | | -2000 (F830 hex) | Process value L (low limit) alarm setting | |
| | | | | | | | Span adjustment value |
| m + 4 | m + 8 | m + 12 | m + 16 | 0 to 9999 | 0000 to 270F hex | 1000 (03E8 hex) | m+32 contains 0: Set value × 0.001 |
| | | | | 0 to 32000 | 0000 to 7D00 hex | 10000 (2710 hex) | m+32 contains 1: Set value × 0.0001 |
| | | | | | | | Zero adjustment value |
| m + 5 | m + 9 | m + 13 | m + 17 | -9999 to 9999 | D8F1 to 270F hex | 0 (0000 hex) | Set value × 0.1 |
| Setting Group 2 (initial settings area): Parameters that are transferred one time from the CPU Unit to the Resistance Thermometer Input Unit if word m contains other than 12345 when the PLC is turned ON or the Resistance Thermometer Input Unit is restarted. | | | | | | | |
| | | | | | | | Operation settings (See note 2.) |
| m + 18 | | | | (See note 2.) | (See note 2.) | 0 (0000 hex) | 00 to 03: Temperature unit (°C or °F) 04 to 07: Data display (binary or BCD) 08 to 11: Minus sign display format for BCD display 12 to 15: Data direction at sensor error |
| | | | | | | | Sensor type |
| m + 19 | | | | 0, 1 | 0000, 0001 hex | 0 (0000 hex) | 0: Pt100; 1: JPt100 |
| | | | | | | | External alarm output mode |
| m + 20 | m + 23 | m + 26 | m + 29 | 0, 1 | 0000, 0001 hex | 0 (0000 hex) | Select either high limit or low limit alarm output. 0: High limit alarm; 1: Low limit alarm |
| | | | | | | | Alarm hysteresis |
| m + 21 | m + 24 | m + 27 | m + 30 | 0 to 9999 | 0000 to 270F hex | 0 (0000 hex) | Set value × 0.1 |
| | | | | | | | Alarm ON-delay time |
| m + 22 | m + 25 | m + 28 | m + 31 | 0 to 60 | 0000 to 003C hex | 0 (0000 hex) | Unit: s |
| m + 32 | | | | 0, 1 | 0000, 0001 hex | 1 (See note 3.) | Span adjustment mode 0: 1/1,000 1: 1/10,000 |

Note 1. The ERC indicator on the Unit's front panel will light if an out-of-range setting is made in either Setting Group 1 or 2. The offset from word m to the

first word containing the out-of-range error will be stored as the Address of Data Range Error in the DM Area in four digits hexadecimal.

2. The operation settings are shown in the following table.

| Word | Bits | Description | Settings |
|------|------|---|---|
| m+18 | 00 | Temperature unit setting | 0: °C 1: °F |
| | 04 | Data format | 0: Binary (Negative values are given as 2's complements). 1: BCD |
| | 08 | Minus sign display format for BCD display | 0: "F" used to indicate the minus sign. 1: Leftmost bit used to indicate the minus sign. The setting is disabled if bits 04 to 07 are set to 0. |
| | 12 | Data direction at sensor error | 0: Goes to upper limit at sensor error 1: Goes to lower limit at sensor error |

Example: For a temperature in degrees Celsius (°C), a binary data format, and a data direction at sensor error of "lower limit," word m+18 contains 1000.

3. Indicates the value after transferring the default value (set when 12345 is written to word m).

CIO Area Allocations

First word: word n. n = 2000 + unit number × 10 (unit number: 0 to 95)

| Direction | Word | Bit | Name | | Data range | Contents |
|---|----------|-----------|-------------|------------------------------------|---------------------------|--|
| Resistance Thermometer Input Unit to CPU Unit | n | 00 | Input No. 1 | Process value L (low limit) alarm | 0, 1 | 0: Process value > Set value 1: Process value ≤ Set value |
| | | 01 | | Process value H (high limit) alarm | 0, 1 | 0: Process value < Set value 1: Process value ≥ Set value |
| | | 02 | Input No. 2 | Process value L (low limit) alarm | 0, 1 | Same as for input No. 1. |
| | | 03 | | Process value H (high limit) alarm | 0, 1 | |
| | | 04 | Input No. 3 | Process value L (low limit) alarm | 0, 1 | |
| | | 05 | | Process value H (high limit) alarm | 0, 1 | |
| | | 06 | Input No. 4 | Process value L (low limit) alarm | 0, 1 | |
| | | 07 | | Process value H (high limit) alarm | 0, 1 | |
| | 08 to 15 | Not used. | | | | |
| | n + 1 | 00 to 15 | Input No. 1 | Process value | Depends on type of input. | |
| | n + 2 | 00 to 15 | Input No. 2 | | | |
| | n + 3 | 00 to 15 | Input No. 3 | | | |
| | n + 4 | 00 to 15 | Input No. 4 | | | |
| | n + 5 | Not used. | | | | |
| | n + 6 | | | | | |
| | n + 7 | | | | | |
| n + 8 | | | | | | |

| Direction | Word | Bit | Name | | Data range | Contents |
|---|-------|----------|---|--------------|-------------------------------------|-----------------------|
| Resistance Thermometer Input Unit to CPU Unit | n + 9 | 00 | Input No. 1 | Sensor error | 0, 1 | 0: Normal 1: Error |
| | | 01 | Input No. 2 | | 0, 1 | |
| | | 02 | Input No. 3 | | 0, 1 | |
| | | 03 | Input No. 4 | | 0, 1 | |
| | | 04 to 14 | Not used. | | | |
| | 15 | 15 | Conversion data enabled flag. (See note.) | 0, 1 | 0: Data disabled 1: Data enabled | |

Note The Conversion Data Enabled Flag remains OFF after the PLC is turned ON or the Unit is restarted until the AD conversion data becomes stable (approximately 2 to 4 s), then is ON during operation.

Terminal Connection Diagram

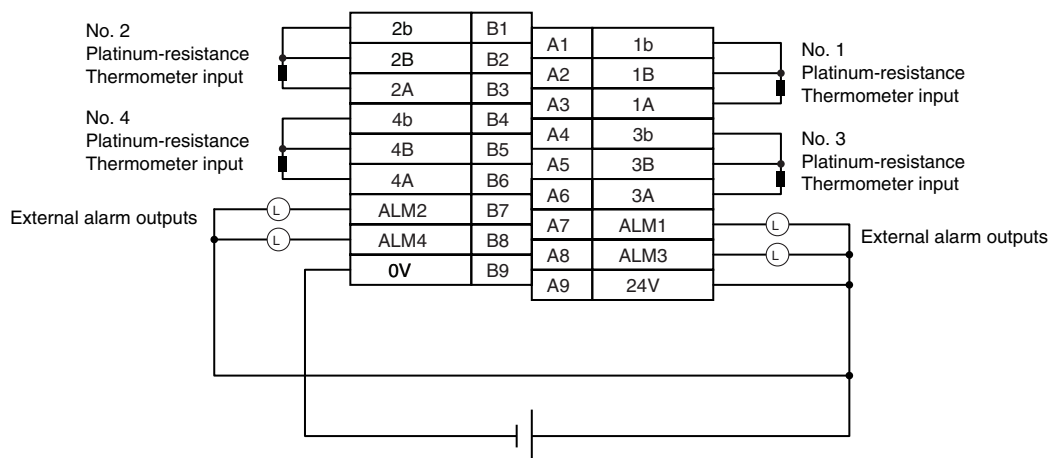

- Note**
- Wire the same length to A, B, and b, so that the impedance will be the same. In particular, do not short circuit between B and b at the terminal block.
 - For unused input terminals, connect approximately 100 Ω between the platinum-resistance thermometer input terminals A and B and short terminals B and b with a lead wire. If resistance is not connected between terminals A and B and terminals B and b are shorted or if terminals A and B and terminals B and b are left open, the alarm output will turn ON and the ALM indicator will light.
 - Always ground the GR terminal on the Power Supply Unit of the PLC.
 - If the input device uses a voltage generator, temperature compensator, or similar device, then ground the input device if it has a ground terminal.

Terminal Block Diagram

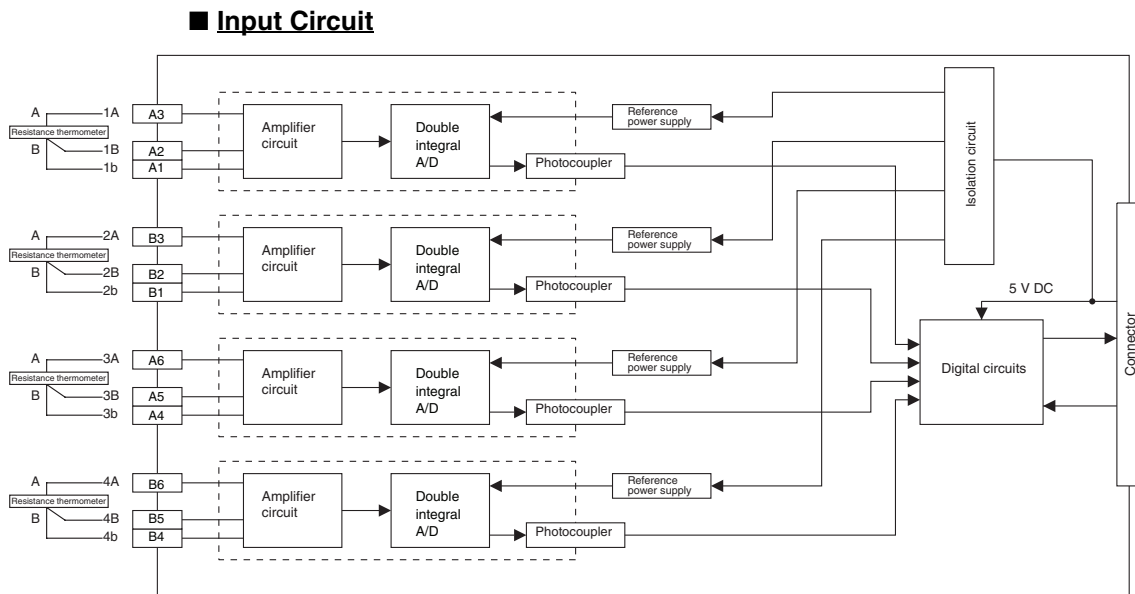

■ Output Circuit

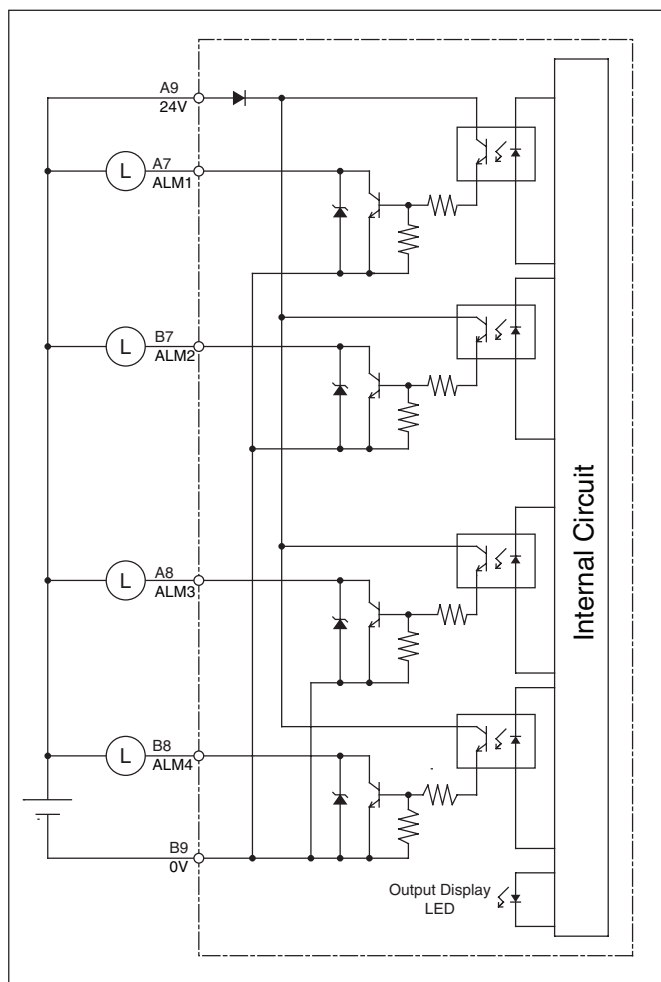

Error Processing**Conversion Data Does Not Change.**

| Probable cause | Remedy |
|---|--|
| The gain for span adjustment is set to 0. | Set the gain for span adjustment to a value other than 0. |
| The sensor type is not set correctly. | Check and reset the sensor type. |
| An input device is malfunctioning, input wiring is faulty, or wiring is disconnected. | Check whether the resistance has changed. Check for faulty or disconnected wiring. Check whether a sensor error has been detected in the I/O Area. |

Values are Not Converted as Intended.

| Probable cause | Remedy |
|---|--|
| The sensor type is set incorrectly. | Check and reset the sensor type settings. |
| The zero/span adjustment data is incorrect. | Check and correct the zero/span adjustment settings. |
| The platinum-resistance thermometer input wiring is faulty. | Check and correct the input wiring. |
| The compensating conductor is too long and measurements are being affected by conductor resistance. | Use a thicker compensating conductor. |

Converted Values are Unstable.

| Probable cause | Remedy |
|---|---|
| Input signals are being affected by external noise. | Change the connection paths of the input signal lines. (Separate them from sources of noise or use shielded cable.) |

3-4 CJ1W-PTS16 Isolated-type Resistance Thermometer Input Unit (Pt100, JPt100, Pt50, Ni508.4)

Overview

The CS1W-PTS16 Isolated-type Resistance Thermometer Input Unit provides two direct resistance thermometer inputs, and sends the data to the CPU Unit each cycle. All inputs are isolated.

CS1W-PTS16

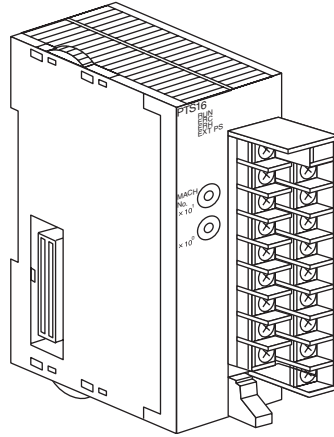

System Configuration

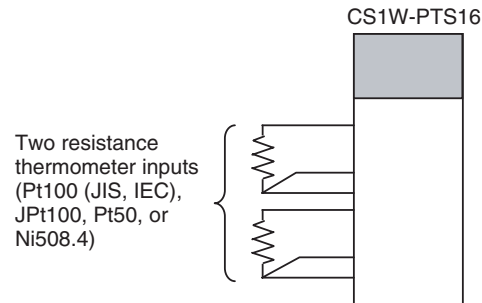

Features

- Up to two resistance thermometers can be connected for each Unit (with two separate settings for temperature sensors and input ranges).
- Pt100 (JIS, IEC), JPt100, Pt50, or Ni508.4 can be selected.
- 1/64,000 resolution for all temperature specifications.
- High-speed conversion of 10 ms/2 inputs.
- Temperature sensor values are transmitted to the CPU Unit in four digits hexadecimal.
- Variable input range setting.
- Four values for each process value alarm input.
- ON-delay timer for process value alarm.
- Mean value processing.
- Rate-of-change calculation.
- Two values for each rate-of-change alarm input.
- Zero/span adjustment capability during operation.
- Disconnection detection.
- Maximum or minimum process value can be specified for when a disconnection is detected.
- Adjustment period control.

- Peak and bottom detection.
- Top and valley detection.

Model Information

| Unit classification | Model number | Inputs | Input types |
|----------------------------|--------------|--------|---|
| CJ-series Special I/O Unit | CJ1W-PTS16 | 2 | Resistance thermometer Pt100 (JIS, IEC), JPt100, Pt50, or Ni508.4 |

Block Diagram (Order of Processing)

The processing for the inputs is as shown in the following diagram.

CPU Unit

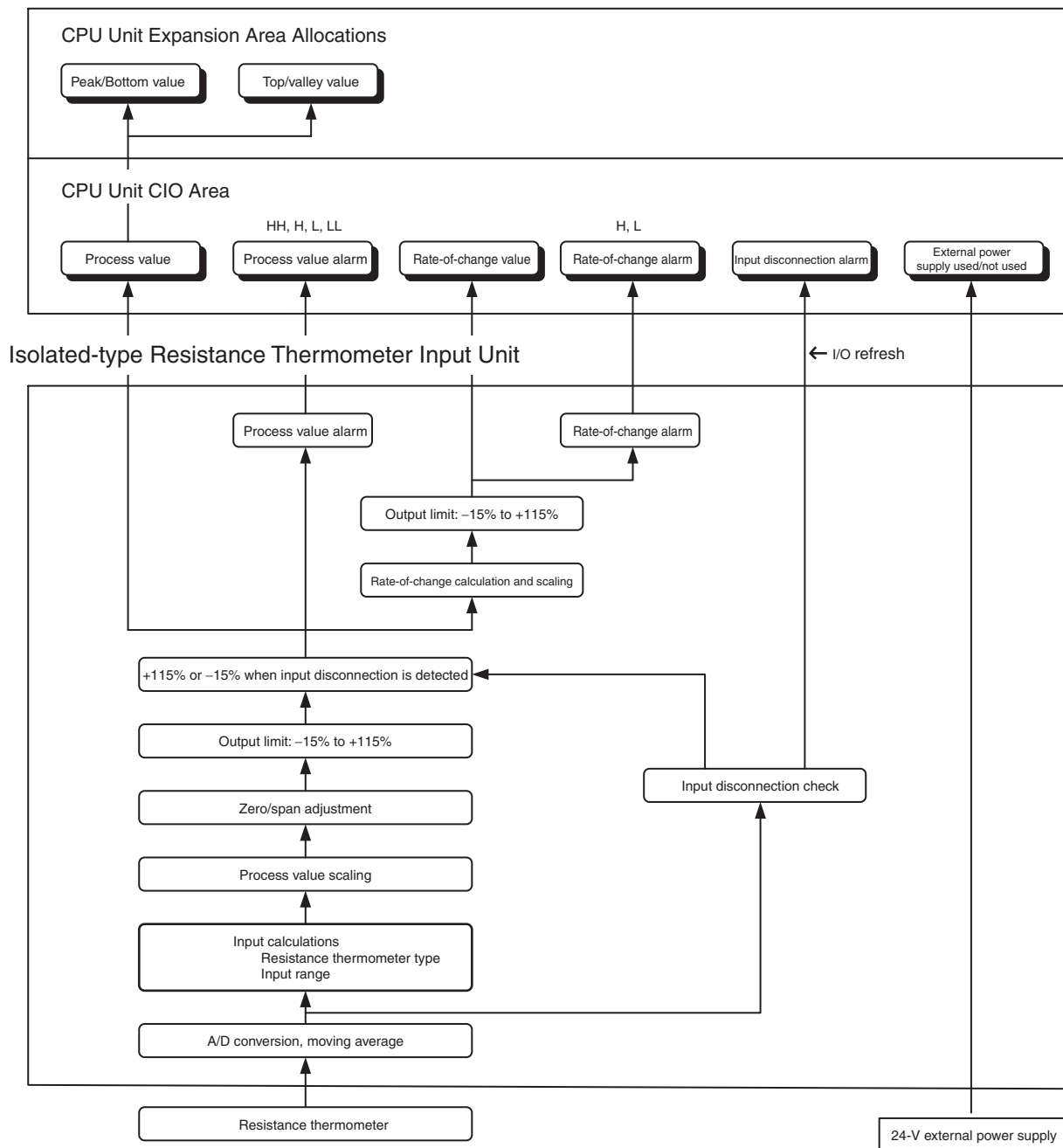

Specifications

| Item | | Specifications |
|--|--|--|
| Model | | CJ1W-PTS16 |
| Applicable PLC | | CJ Series |
| Unit classification | | CJ-series Special I/O Unit |
| Mounting position | | CJ-series CPU Rack or CJ-series Expansion Rack |
| Maximum number of Units | | 40 (within the allowable current consumption and power consumption range) |
| Unit numbers | | 00 to 95 (Cannot duplicate Special I/O Unit numbers.) |
| Areas for data exchange with CPU Unit | Special I/O Unit Area | 10 words/Unit Resistance Thermometer Input Unit to CPU Unit: All process values, process value alarms (LL, L, H, HH), rate-of-change values, rate-of-change alarms (L, H), disconnection alarms, adjustment period end/notices. |
| | DM Area words allocated to Special I/O Units | 100 words/Unit CPU Unit to Resistance Thermometer Input Unit: Temperature sensor type, input range (user set), scaling of process value data to be stored in allocated words in CIO area, rate-of-change input range, scaling of rate-of-change data, number of items for moving average, process value alarm setting (LL, L, H, HH), rate-of-change alarm setting (L, H), zero/span adjustment value. |
| | Expansion Control/Monitor Area words | 35 words/Unit CPU Unit to Resistance Thermometer Input Unit: Hold function selection start/reset, adjustment period control, control bits Resistance Thermometer Input Unit to CPU Unit: Adjustment period warnings/notices, peak and bottom values, top and valley values |
| | Expansion Setting Area words | 46 words/Unit CPU Unit to Resistance Thermometer Input Unit: Expansion Setting Area settings, adjustment period control, peak and bottom detection, top and valley detection |
| Number of temperature sensor inputs | | 2 |
| Temperature sensor type | | Pt100 (JIS, IEC), JPt100, Pt50, Ni508.4 Sensor type, input range, and scaling to industrial units are separate for each of the 2 inputs. |
| Scaling | | Data to be stored in the allocated words in the CIO area must be scaled (with the minimum and maximum values set by user) (2 inputs set separately). Data can be stored at 0% to 100%. |
| Data storage in the CIO Area | | The value derived from carrying out the following processing in order of the actual process data in the input range is stored in four digits hexadecimal (binary values) in the allocated words in the CIO Area. 1) Mean value processing → 2) Scaling → 3) Zero/span adjustment → 4) Output limits |
| Accuracy (25°C) | | The greater of the following: ±0.05% or ±0.1°C |
| Temperature coefficient | | Pt100: 0.009%/°C JPt100: 0.01%/°C Pt50: 0.02%/°C Ni508.4: 0.012%/°C |
| Resolution | | 1/64,000 |
| Sensing method | | 3-wire method |
| Allowable lead wire resistance | | 20 Ω max. per wire |
| Input detection current | | 0.5 mA |
| Warmup time | | 10 min |
| Response time | | 100 ms (travel time from input 0% to 90%, for step input and with moving average for 4 samples) |
| Conversion period | | 10 ms/2 inputs |
| Maximum time to store data in CPU Unit | | Conversion period + one CPU Unit cycle |

| Item | | Specifications |
|-------------------------------|--------------------------------------|---|
| Disconnection detection | | Detects disconnections at each input and turns ON the Disconnection Detection Flag. Hardware detection time: Approx. 0.5 s max. The process value overrange direction for when a disconnection occurs can be specified. (High: 115% of set input range; low: -15% of set input range) |
| Function | Mean value processing (input filter) | Calculates the moving average for the specified number of process values (1 to 128), and stores that value in the CIO Area as the process value. |
| | Process value alarm | Process value 4-point alarm (HH, H, LL, L), alarm hysteresis, and ON-delay timer (0 to 60 s are available). |
| | Rate-of-change calculation | Calculates the amount of change per comparison time interval (1 to 16 s). |
| | Rate-of-change alarm | Rate-of-change 2-point alarm (H, L), alarm hysteresis, and ON-delay timer (0 to 60 s are available, shared with process value alarm). |
| | Adjustment period control | When zero/span adjustment is executed, the date is internally recorded at the Unit. When the preset zero/span adjustment period and the notice of days remaining have elapsed, this function turns ON a warning flag to give notice that it is time for readjustment. |
| | Peak and bottom detection | Detects the maximum (peak) and minimum (bottom) analog input values, from when the Hold Start Bit (output) allocated to the Expansion Control/Monitor Area turns ON until it turns OFF. These values are stored as the peak and bottom values in the Expansion Control/Monitor Area. |
| Top and valley detection | | This function detects the top and valley values for analog inputs, from when the Hold Start Bit (output) allocated to the Expansion Control/Monitor Area turns ON until it turns OFF. These values are stored as the top and valley values in the Expansion Control/Monitor Area. |
| Isolation | | Between temperature inputs and between input terminals and PLC signals: Power supply isolated by transformers, signals isolated by photocouplers. |
| Insulation resistance | | 20 M Ω (at 500 V DC) between inputs |
| Dielectric strength | | Between inputs: 1,000 V AC, at 50/60 Hz, for 1 min, leakage current 10 mA max. |
| External connections | | Terminal block (detachable) |
| Unit number settings | | Set by rotary switches on front panel, from 0 to 95. |
| Indicators | | Four LED indicators on front panel (for normal operation, errors detected at the Resistance Thermometer Input Unit, errors detected at the CPU Unit, and use of external power supply). |
| Front panel connector | | Sensor input connector terminal block (detachable) |
| Effect on CPU Unit cycle time | | 0.3 ms |
| Current consumption | | 5 V DC at 180 mA max. |
| External power supply | | 24 VDC +10%/-15% 70 mA max., inrush current: 20 A for 1 ms max. (The external 24-VDC power supply must be isolated.) |
| Dimensions | | 31 × 90 × 65 mm (W × H × D) |
| Weight | | 150 g max. |
| Standard accessories | | None |

Sensor Type and Input Range

The resistance thermometer type and input range are set in the allocated words in the DM Area for every four inputs. The input range can be set anywhere within the measurable input ranges shown in the following table. Accuracy and resolution, however, are not determined from the set input range, but rather from the measurable input range shown in the following table. Therefore, accuracy and resolution do not change even when a narrow input range is set.

| Sensor type | DM Area setting | Measurable input range |
|-------------|-----------------|------------------------|
| Pt100 | 0 | -200 to 850°C |
| JPt100 | 1 | -200 to 500°C |

| Sensor type | DM Area setting | Measurable input range |
|-------------|-----------------|------------------------|
| Pt50 | 2 | -200 to 649°C |
| Ni508.4 | 3 | -50 to 150°C |

DM Area Allocations

First word: word m. m = D20000 + unit number × 100 (unit number: 0 to 95)

| DM Area address | | Data range | | Default | Data contents |
|--|-------------|-----------------|------------------------------------|------------------|--|
| Input No. 1 | Input No. 2 | Decimal | Hexadecimal | | |
| m | | 12345, 0 | 3039, 0000 hex | 0000 hex | Default block read command Specifies the direction of data transfer when the PLC is turned ON or the Unit is restarted for DM Area words m+1 to m+93. <ul style="list-style-type: none"> 12345 (3039 hex): The data in words m+1 to m+93 is transferred from the Resistance Thermometer Input Unit to the CPU Unit. When the transfer is completed, the value will become 0000 hex. Other than 12345 (3039 hex) (such as 0000 hex): The data in the allocated words of DM Area is transferred from the CPU Unit to the Resistance Thermometer Input Unit. |
| m+1 | | --- | --- | 0 (0000 hex) | Not used. |
| Setting Group 1 (continuously refreshed area): Parameters that are continuously refreshed during PLC operation (regardless of the CPU Unit's operation mode) | | | | | |
| | | | | | Process value alarm settings |
| m + 2 | m + 10 | -32768 to 32767 | 8000 to FFFF hex, 0000 to 7FFF hex | 4200 (1068 hex) | Process value HH (high high limit) alarm setting (Set at process value scaling value.) |
| m + 3 | m + 11 | -32768 to 32767 | 8000 to FFFF hex, 0000 to 7FFF hex | 4000 (0FA0 hex) | Process value H (high limit) alarm setting (Set at process value scaling value.) |
| m + 4 | m + 12 | -32768 to 32767 | 8000 to FFFF hex, 0000 to 7FFF hex | 0 (0000 hex) | Process value L (low limit) alarm setting (Set at process value scaling value.) |
| m + 5 | m + 13 | -32768 to 32767 | 8000 to FFFF hex, 0000 to 7FFF hex | -200 (FF38 hex) | Process value LL (low low limit) alarm setting (Set at process value scaling value.) |
| | | | | | Rate-of-change value alarm settings |
| m + 6 | m + 14 | -32768 to 32767 | 8000 to FFFF hex, 0000 to 7FFF hex | 4000 (0FA0 hex) | Rate-of-change value H (high limit) alarm setting (Set at rate-of-change scaling value.) |
| m + 7 | m + 15 | -32768 to 32767 | 8000 to FFFF hex, 0000 to 7FFF hex | 0 (0000 hex) | Rate-of-change value L (low limit) alarm setting (Set at rate-of-change scaling value.) |
| | | | | | Zero/span adjustment |
| m + 8 | m + 16 | 0 to 32000 | 0000 to 7D00 hex | 10000 (2710 hex) | Gain for span adjustment (set value x 0.0001%) |
| m + 9 | m + 17 | -32000 to 32000 | 8300 to FFFF hex, 0000 to 7D00 hex | 0 (0000 hex) | Zero adjustment value (Set at process value scaling.) |
| Setting Group 2 (initial settings area): Parameters that are transferred one time from the CPU Unit to the Resistance Thermometer Input Unit if word m contains other than 12345 when the PLC is turned ON or the Resistance Thermometer Input Unit is restarted. | | | | | |
| | | | | | Sensor type |
| m+34 | m+49 | 0 to 3 | 0000 to 0003 hex | 0 (0000 hex) | 0: Pt100; 1: JPt100; 2: Pt50; 3: Ni508.4 |
| | | | | | Process value input range settings |
| m+35 | m+50 | -32000 to 32000 | 8300 to FFFF hex, 0000 to 7D00 hex | 4000 (0FA0 hex) | Maximum input signal value (set value x 0.1°C/°F) |
| m+36 | m+51 | -32000 to 32000 | 8300 to FFFF hex, 0000 to 7D00 hex | 0 (0000 hex) | Minimum input signal value (set value x 0.1°C/°F) |
| m+37 | m+52 | 0, 1 | 0000, 0001 hex | 0 (0000 hex) | Unit 0: °C, 1: °F |

| DM Area address | | Data range | | Default | Data contents | |
|---|-------------|---------------------|------------------------------------|------------------|--|--|
| Input No. 1 | Input No. 2 | Decimal | Hexadecimal | | | |
| | | | | | Process value overrange direction at time of input disconnection | |
| m+38 | m+53 | 0, 1 | 0000, 0001 hex | 0 (0000 hex) | 0: High; 1: Low | |
| | | | | | Process value scaling | |
| m+39 | m+54 | -32000 to 32000 | 8300 to FFFF hex, 0000 to 7D00 hex | 4000 (0FA0 hex) | Value stored for maximum value in range (span) | |
| m+40 | m+55 | -32000 to 32000 | 8300 to FFFF hex, 0000 to 7D00 hex | 0 (0000 hex) | Value stored for minimum value in range (zero) | |
| | | | | | Alarm supplementary functions | |
| m+41 | m+56 | 0 to 32000 | 0000 to 7D00 hex | 40 (0028 hex) | Alarm hysteresis (Set at process value scaling value. Shared with process value alarm and rate-of-change alarm.) | |
| m+42 | m+57 | 0 to 60 | 0000 to 003C hex | 0 (0000 hex) | Alarm ON-delay time (Unit: s) (Shared with process value alarm and rate-of-change alarm.) | |
| | | | | | Rate-of-change function | |
| m+43 | m+58 | -32000 to 32000 | 8300 to FFFF hex, 0000 to 7D00 hex | 4000 (0FA0 hex) | Rate-of-change range setting | Maximum rate-of-change value (Set value industrial unit; comparison time interval) |
| m+44 | m+59 | -32000 to 32000 | 8300 to FFFF hex, 0000 to 7D00 hex | -4000 (F060 hex) | | Minimum rate-of-change value (Set value industrial unit; comparison time interval) |
| m+45 | m+60 | 1 to 16 | 0001 to 0010 hex | 1 (0001 hex) | Rate-of-change comparison time interval (Unit: s) | |
| m+46 | m+61 | -32000 to 32000 | 8300 to FFFF hex, 0000 to 7D00 hex | 4000 (0FA0 hex) | Rate-of-change value scaling | Value stored for maximum value in range |
| m+47 | m+62 | -32000 to 32000 | 8300 to FFFF hex, 0000 to 7D00 hex | -4000 (F060 hex) | | Value stored for minimum value in range |
| | | | | | Mean value processing function | |
| m+48 | m+63 | 1 to 128 | 0001 to 0080 hex | 25 (0019 hex) | Number of process values for calculating moving average for mean value processing | |
| Display parameter | | | | | | |
| m+94 | m+95 | 0 to 99, 100 to 1XX | 0000 to 0063 hex, 0064 to 0XXX hex | 0 (0000 hex) | Address of Data Range Error (See note.) | |
| Expansion Setting Area allocation settings | | | | | | |
| m+98 | | 0 to 5 | 0000 to 0005 hex | --- | Expansion Setting Area allocation 0: Not used; 1: DM; 2: CIO; 3: W; 4: H; 5: EM | |
| m+99 | | 0 to 32767 | 0000 to 7FFF hex | --- | First word for Expansion Setting Area | |

- Note**
- The ERC indicator on the Unit's front panel will light if an out-of-range setting is made in either Setting Group 1 or 2, or in the Expansion Setting Area. The offset from word m to the first word containing the out-of-range error will be stored as the Address of Data Range Error in the DM Area in four digits hexadecimal. For more information, refer to *1-6 Error Processing*.

If the first memory address where the out-of-range error occurred is in the Expansion Setting Area, the Address of Data Range Area will be +100 or later. If the first word of the Expansion Setting Area has the error, the Address of Data Range Area will be +100.

- When specifying an expansion setting area, be sure that it does not overlap with other areas that are being used. If areas overlap, the words that are allocated may be overwritten, resulting in unexpected operation.
- When specifying the first word in an expansion setting area, be sure that the end of the memory area is not exceeded.

Expansion Setting Area Allocations

First word: word o. o = address specified in word m+99 in the area specified by word m+98 in the DM Area.

| DM Area address | | Data range | | Default | Data contents |
|---|--------------|-----------------|------------------------------------|-----------------|--|
| Input No. 1 | Input No. 2 | Decimal | Hexadecimal | | |
| Setting Group 3 (initial settings area): Parameters that are transferred one time from the CPU Unit to the Resistance Thermometer Input Unit if word m contains other than 12345, and if Expansion Setting Area settings are allocated, when the PLC is turned ON or the Resistance Thermometer Input Unit is restarted. | | | | | |
| | | | | | Expansion Control/Monitor Area settings |
| o | | 0 to 5 | 0000 to 0005 hex | --- | Expansion Control/Monitor Area allocation 0: Not used. 1: DM; 2: CIO; 3: W; 4: H; 5: EM |
| o+1 | | 0 to 32767 | 0000 to 7FFF hex | --- | Expansion Control/Monitor Area first word |
| | | | | | Zero/span adjustment supplementary function |
| o+2 | o+13 | 0 to 32000 | 0000 to 7D00 hex | 1000 (2710 hex) | Span adjustment position (Input span percentage) |
| o+3 | o+14 | -32000 to 32000 | 8300 to FFFF hex, 0000 to 7D00 hex | 0 (0000 hex) | Zero adjustment position (Input span percentage) |
| o+4 | o+15 | 0 to 9999 | 0000 to 270F hex | 365 (016D hex) | Zero/span adjustment period (Unit: Days) |
| o+5 | o+16 | 0 to 9999 | 0000 to 270F hex | 30 (001E hex) | Notice of days remaining (Unit: Days) |
| | | | | | Not used. |
| o+6 to o+8 | o+17 to o+19 | --- | --- | 0 (0000 hex) | Not used. |
| | | | | | Top and valley hold |
| o+9 | o+20 | 0 to 32000 | 0000 to 7D00 hex | 40 (0028 hex) | Hysteresis |
| | | | | | Not used. |
| o+10 to o+12 | o+21 to o+23 | --- | --- | 0 (0000 hex) | Not used. |

- Note**
1. When specifying an expansion control/monitor area be sure that it does not overlap with other areas that are being used. If areas overlap, the words that are allocated may be overwritten, resulting in unexpected operation.
 2. When specifying the first word in an expansion control/monitor area be sure that the end of the memory area is not exceeded.

CIO Area Allocations

First word: word n. $n = 2000 + \text{unit number} \times 10$ (unit number: 0 to 95)

| Direction | Word | Bit | Name | | Data range | Contents |
|---|----------|-----|-------------|--|------------|------------------------------|
| Resistance Thermometer Input Unit to CPU Unit | n | 00 | Input No. 1 | Process value LL (low low limit) alarm | 0, 1 | 0: Process value > Set value |
| | | 01 | | Process value L (low limit) alarm | 0, 1 | 1: Process value ≤ Set value |
| | | 02 | | Process value H (high limit) alarm | 0, 1 | 0: Process value < Set value |
| | | 03 | | Process value HH (high high limit) alarm | 0, 1 | 1: Process value ≥ Set value |
| | | 04 | Input No. 2 | Process value LL (low low limit) alarm | 0, 1 | Same as for input No. 1. |
| | | 05 | | Process value L (low limit) alarm | 0, 1 | |
| | | 06 | | Process value H (high limit) alarm | 0, 1 | |
| | | 07 | | Process value HH (high high limit) alarm | 0, 1 | |
| | 08 to 15 | | Not used. | | 0 | --- |

| Direction | Word | Bit | Name | | Data range | Contents | |
|---|-----------------|----------|------------------------------------|---------------------------------|--|--|--|
| Resistance Thermometer Input Unit to CPU Unit | n + 1 | 00 to 15 | Input No. 1 process value | | -32768 to 32767 (8000 to FFFF hex, 0000 to 7FFF hex) | The present process value is stored according to the scaling set in the allocated words of the DM Area. | |
| | n + 2 | 00 to 15 | Input No. 2 process value | | -32768 to 32767 (8000 to FFFF hex, 0000 to 7FFF hex) | | |
| | n + 3, n + 4 | --- | Not used. | | 0000 | --- | |
| | n + 5 | 00 to 15 | Input No. 1 rate-of-change value | | -32768 to 32767 (8000 to FFFF hex, 0000 to 7FFF hex) | The present rate of change is stored according to the scaling set in the allocated words of the DM Area. | |
| | n + 6 | 00 to 15 | Input No. 2 rate-of-change value | | -32768 to 32767 (8000 to FFFF hex, 0000 to 7FFF hex) | | |
| | n + 7, n + 8 | --- | Not used. | | 0000 | --- | |
| | n + 9 | 00 | | Input No. 1 | Rate-of-change value L (low limit) alarm | 0, 1 | 0: Rate-of-change value > Set value 1: Rate-of-change value ≤ Set value |
| | | | | | Rate-of-change value H (high limit) alarm | 0, 1 | 0: Rate-of-change value < Set value 1: Rate-of-change value ≥ Set value |
| | | 02 | | Input No. 2 | Rate-of-change value L (low limit) alarm | 0, 1 | Same as for input No. 1. |
| | | | | | Rate-of-change value H (high limit) alarm | 0, 1 | |
| | | 04 to 07 | | | Not used. | 0 | --- |
| | | 08 | | | Input No. 1 input error | 0, 1 | 0: Normal 1: Disconnection |
| | | 09 | | | Input No. 2 input error | 0, 1 | |
| | 10 to 12 | | | Not used. | 0 | --- | |
| | 13 | | | Zero/span adjustment period end | 0, 1 | 0: Adjustment enabled 1: Adjustment ended | |
| 14 | | | Zero/span adjustment period notice | 0, 1 | 0: Adjustment enabled 1: Notice period | | |
| 15 | | | External power supply | 0, 1 | 0: External power supply not used 1: External power supply used | | |

Note The External Power Supply Flag turns ON after external power is supplied and the internal voltage stabilizes (which requires approximately 2 s). The indicator on the front of the Unit will turn ON as soon as external power is supplied.

Expansion Control/Monitor Area Allocations

First word: word p. p = address specified in word o+1 in the area specified by word o in the Expansion Setting Area.

| Direction | Word | Bit | Name | Data range | Contents |
|---|------|----------|---|------------|--|
| CPU Unit to Resistance Thermometer Input Unit | p | 00 to 15 | Not used. | Not used. | Not used. |
| | p+1 | 00 | Input No. 1 hold function selection | 0, 1 | 0: Peak and bottom 1: Top and valley |
| | | 01 | Input No. 2 hold function selection | 0, 1 | |
| | | 02 to 07 | Not used. | 0 | Not used. |
| | | 08 | Input No. 1 hold start | 0, 1 | 0: Do not hold. |
| | | 09 | Input No. 2 hold start | 0, 1 | 1: Hold |
| | | 10, 11 | Not used. | 0 | Not used. |
| | | 12 | Input No. 1 hold value reset | 0, 1 | 0: Normal operation 1: Reset hold value. |
| | | 13 | Input No. 2 hold value reset | 0, 1 | |
| | | 14, 15 | Not used. | 0 | Not used. |
| | p+2 | 00 | Input No. 1 zero/span adjustment update bit | 0, 1 | 0: Normal operation |
| | | 01 | Input No. 2 zero/span adjustment update bit | 0, 1 | 1: Update adjustment date (Remains ON while writing external FROM.) |
| | | 02 to 15 | Not used. | 0 | Not used. |

| Direction | Word | Bit | Name | | Data range | Contents |
|---|-------------|-----------|--------------------------|---|---|---|
| Resistance Thermometer Input Unit to CPU Unit | p+3 | 00 | Input No. 1 | Zero/span adjustment period end | 0, 1 | 0: Adjustment enabled. 1: Adjustment period end |
| | | 01 | | Zero/span adjustment period notice | 0, 1 | 0: Adjustment enabled. 1: Notice period in effect. |
| | | 02 | Input No. 2 | Zero/span adjustment period end | 0, 1 | Remains set to 1 if the zero/span adjustment bit has never been ON. |
| | | 03 | | Zero/span adjustment period notice | 0, 1 | |
| | | 04 to 07 | Not used. | | 0 | Not used. |
| | | 08 | External FROM Error Flag | | 0, 1 | 0: Normal operation 1: External FROM error |
| | | 09 to 15 | Not used. | | 0 | Not used. |
| | p+4 | 00 to 15 | Input No. 1 | Day of final adjustment date | 0100 to 3100 (BCD) | Remains set to FFFF if the zero/span adjustment bit has never been ON. |
| | p+5 | 00 to 15 | | Year and month of final adjustment date | 0001 to 9912 (BCD) | |
| | p+6 | 00 to 15 | Input No. 2 | Day of final adjustment date | 0100 to 3100 (BCD) | |
| | p+7 | 00 to 15 | | Year and month of final adjustment date | 0001 to 9912 (BCD) | |
| | p+8 to p+15 | --- | Not used. | | 0 | Not used. |
| | p+16 | 00 to 15 | Input No. 1 | Peak/top value | -32728 to +32767 (8000 to FFFF hex, 0000 to 7FFF hex) | Counts the number of repetitions of conditional operations set in the Expansion Setting Area. |
| | p+17 | 00 to 15 | | Bottom/valley value | -32728 to +32767 (8000 to FFFF hex, 0000 to 7FFF hex) | |
| | p+18 | 00 to 15 | Input No. 2 | Peak/top value | -32728 to +32767 (8000 to FFFF hex, 0000 to 7FFF hex) | Same as for Input No. 1. |
| | p+19 | 00 to 15 | | Bottom/valley value | -32728 to +32767 (8000 to FFFF hex, 0000 to 7FFF hex) | |
| p+20 to p+34 | --- | Not used. | | 0 (0000 hex) | Not used. | |

Terminal Connection Diagram

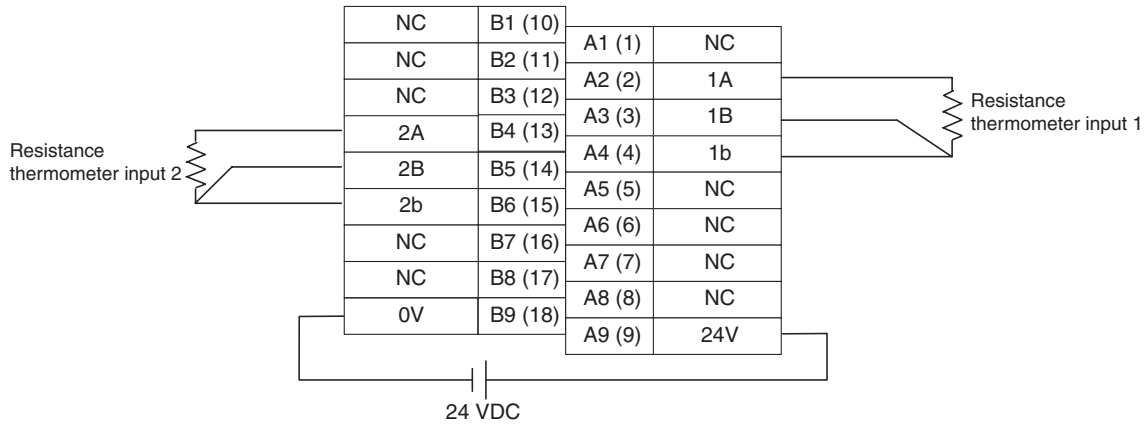

Note

- Wire the same length to A, B, and b, so that the impedance will be the same. In particular, do not short circuit between B and b at the terminal block.
- For unused input terminals, short-circuit between A–B and B–b (e.g., B4–B5 and B5–B6 for input No. 2) of the resistance thermometer inputs with the lead wire.
- Always ground the GR terminal on the Power Supply Unit of the PLC.
- If the input device uses a voltage generator, temperature compensator, or similar device, then ground the input device if it has a ground terminal.

Terminal Block Diagram

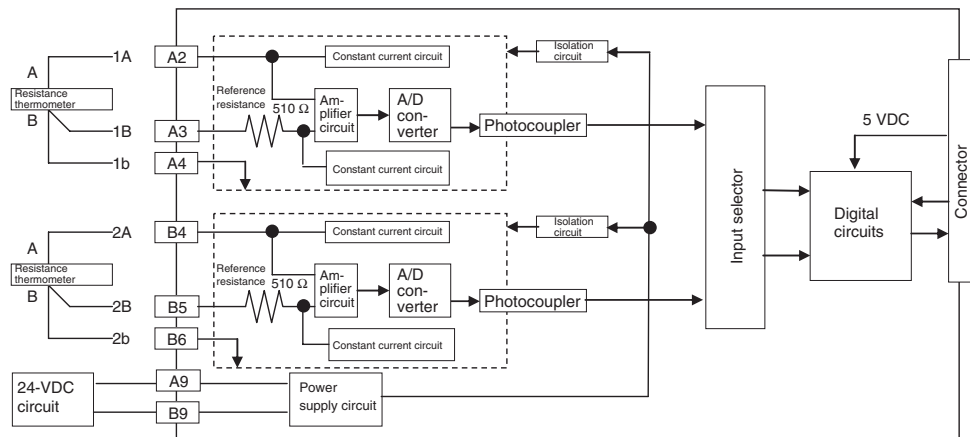

Error Processing

Conversion Data Does Not Change.

| Probable cause | Remedy |
|--|---|
| The gain for span adjustment is set to 0. | Set the gain for span adjustment to a value other than 0. |
| The minimum and maximum values for process value scaling are either the same or are set extremely low. | Set the minimum and maximum process value scaling correctly. |
| The sensor type, or process value scaling is not set correctly. | Check and reset the sensor type, and the process value scaling settings. |
| An input device is malfunctioning, input wiring is faulty, or wiring is disconnected. | Check whether the input voltage or current has changed. Check for faulty or disconnected wiring. Check whether a disconnection has been detected in the I/O Area. |

Values are Not Converted as Intended.

| Probable cause | Remedy |
|---|--|
| The sensor type, or process value scaling is set incorrectly. | Check and reset the sensor type, and the process value scaling settings. |
| The zero/span adjustment data is incorrect. | Check and correct the zero/span adjustment settings. |
| The resistance thermometer input wiring is faulty. | Check and correct the input wiring. |

Converted Values are Unstable.

| Probable cause | Remedy |
|--|---|
| Input signals are being affected by external noise. | Change the connection paths of the input signal lines. (Separate them from sources of noise or use shielded cable.) |
| | Increase the number of values for calculating the moving average in mean value processing. |
| The scaling value is greater than the Unit's resolution. | Reduce the process value scaling. |
| The input signal range is too small. | Change to match the internal range. |

3-5 CJ1W-PDC15 Isolated-type Direct Current Input Unit

Overview

The CJ1W-PDC15 Isolated-type Direct Current Input Unit provides two direct-current inputs, and sends the data to the CPU Unit each cycle. All inputs are isolated.

CJ1W-PDC15

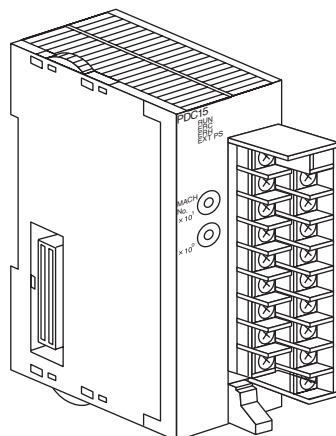

System Configuration

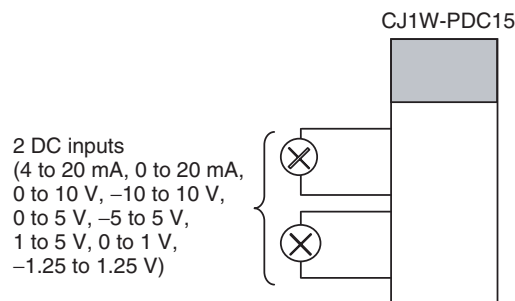

Features

- Up to two DC inputs can be made to each Unit.
4 to 20 mA, 0 to 20 mA, 0 to 10 V, -10 to 10 V, 0 to 5 V, -5 to 5 V, 1 to 5 V, 0 to 1.25 V, or -1.25 to 1.25 V can be selected separately for each input.
- Resolution of 1/64,000 for all input range specifications.
- High-speed conversion, at 10 ms/2 inputs.
- Scaling values are transmitted to the CPU Unit in four digits hexadecimal.
- There is isolation between channels, so unwanted signal paths between input signals can be prevented.
- Square root function.
- Four values for each process value alarm input.
- ON-delay timer for process value alarm.
- Mean value processing.
- Rate-of-change calculation.
- Two values for each rate-of-change alarm input.
- Input error detection.
- Zero/span adjustment capability during operation.
- Adjustment period control.
- Peak and bottom detection.
- Top and valley detection.

- Integral value calculation.

Model Information

| Unit classification | Model number | Inputs | Input types |
|----------------------------|--------------|--------|---|
| CJ-series Special I/O Unit | CJ1W-PDC15 | 2 | 4 to 20 mA, 0 to 20 mA, 0 to 10 V, -10 to 10 V, 0 to 5 V, -5 to 5 V, 1 to 5 V, 0 to 1.25 V, and -1.25 to 1.25 V (separate for each input) |

Block Diagram

CPU Unit

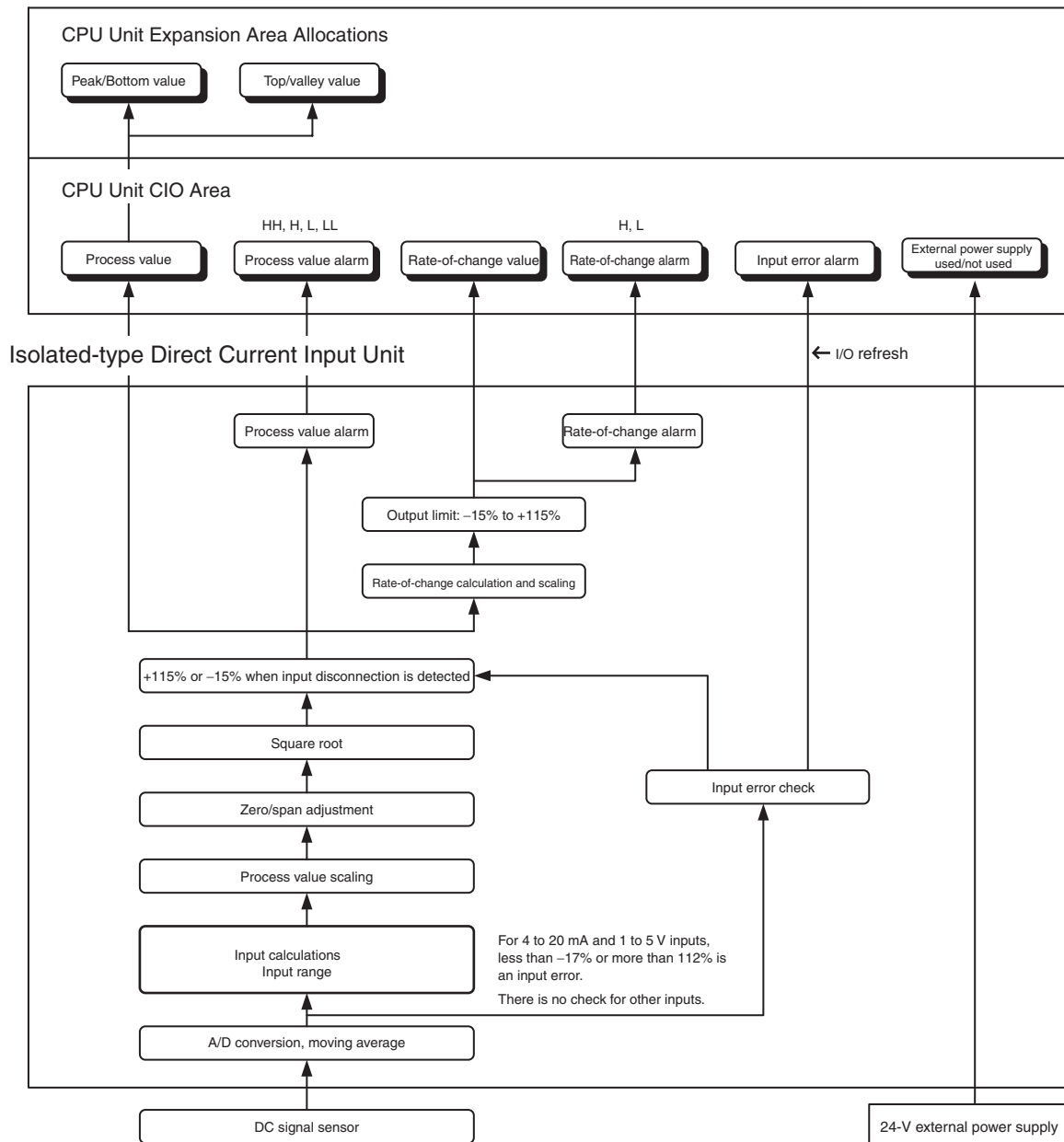

Specifications

| Item | Specifications |
|---------------------|----------------------------|
| Model | CJ1W-PDC15 |
| Applicable PLC | CJ Series |
| Unit classification | CJ-series Special I/O Unit |

| Item | | Specifications |
|--|--|--|
| Mounting position | | CJ-series CPU Rack or CJ-series Expansion Rack |
| Maximum number of Units | | 40 (within the allowable current consumption and power consumption range) |
| Unit numbers | | 00 to 95 (Cannot duplicate Special I/O Unit numbers.) |
| Areas for data exchange with CPU Unit | Special I/O Unit Area | 10 words/Unit Direct Current Input Unit to CPU Unit: All process values, process value alarms (LL, L, H, HH), rate-of-change values, rate-of-change alarms (L, H), disconnection alarms, cold junction sensor errors, adjustment period end/notice |
| | DM Area words allocated to Special I/O Units | 100 words/Unit CPU Unit to Direct Current Input Unit: Input signal type, scaling of process value in industrial units, process value alarm setting (L, H), inrush input upper limit, inrush input upper limit time, zero/span adjustment value, Square root function. Temperature input signal type, input range (user set), scaling of process value data to be stored in allocated words in CIO area, rate-of-change input range, scaling of rate-of-change data, number of items for moving average, process value alarm setting (LL, L, H, HH), rate-of-change alarm setting (L, H), zero/span adjustment value |
| | Expansion Control/Monitor Area | 35 words/Unit CPU Unit to Direct Current Input Unit: Bits for beginning or resetting the hold function selection, adjustment period control, control bits Direct Current Input Unit to CPU Unit: Adjustment period notices, peak and bottom values, top and valley values, integral values |
| | Expansion Setting Area | 46 words/Unit CPU Unit to Direct Current Input Unit: Expansion Setting Area settings, adjustment period control, peak and bottom detection, top and valley detection, integral value calculation |
| Number of inputs | | 2 |
| Input signal type | | 4 to 20 mA, 0 to 20 mA, 0 to 10 V, -10 to 10 V, 0 to 5 V, -5 to 5 V, 1 to 5 V, 0 to 1.25 V, -1.25 to 1.25 V (separate for each input), and ± 10 -V user-set range (specified range within -10.000 V to 10.000 V) |
| Scaling | | Data to be stored in the allocated words in the CIO area must be scaled (Any minimum and maximum values can be set.) (2 inputs set separately.) Data can be converted at 0% to 100%. |
| Data storage in the CIO Area | | The value derived from carrying out the following processing in order of the actual process data in the input range is stored in four digits hexadecimal (binary values) in the allocated words in the CIO Area. 1) Mean value processing → 2) Scaling → 3) Zero/span adjustment → 4) Square root calculation → 5) Output limits |
| Accuracy (25°C) | | $\pm 0.05\%$ |
| Temperature coefficient | | $\pm 0.008\%/^{\circ}\text{C}$ |
| Resolution | | 1/64,000 |
| Input signal range | | For 4 to 20 mA, 0 to 20 mA, 0 to 10 V, 0 to 5 V, 1 to 5 V, 0 to 1.25 V inputs: -15 to 115% For -10 to 10 V, -5 to 5 V, -1.25 to 1.25 V inputs: -7.5 to 107.5% |
| Input impedance | | For current inputs: 250 Ω (typical) For voltage inputs: 1 M Ω min. |
| Warmup time | | 10 min |
| Conversion period | | 10 ms/2 inputs |
| Maximum time to store data in CPU Unit | | Conversion period + one CPU Unit cycle |
| Input error detection | | Check only for 4 to 20 mA and 1 to 5 V. Error detected for -17.2% (1.25 mA, 0.3125 V) or less and 112.5% (22 mA, 5.5 V) or more. |

| Item | | Specifications |
|--|--------------------------------------|--|
| Operation at input disconnection | | For 4 to 20 mA and 1 to 5 V: Stores -15% process value. For all other ranges: Stores same process value as 0-V or 0-mA inputs. |
| Input disconnection detection delay time | | Approx. 1 s. |
| Function | Mean value processing (input filter) | Calculates the moving average for the past specified number of process values (1 to 128 can be specified), and stores that value in the CIO Area as the process value. |
| | Process value alarm | Process value 4-point alarm (LL, L H, HH), hysteresis, and ON-delay timer (0 to 60 s) are available. |
| | Rate-of-change calculation | Calculates the amount of change per comparison time interval (1 to 16 s). |
| | Rate-of-change alarm | Rate-of-change 2-point alarm (H, L), alarm hysteresis, and ON-delay timer (0 to 60 s are available, shared with process value alarm). |
| | Square root calculation | When the maximum value for process value scaling is A and the minimum value is B, Output = $\sqrt{(A - B) \times (\text{input} - B) + B}$ Drop-out: Output approx. 7% max. linear (output = input) characteristic Note 1 The square root function can only be used when the maximum scaling value is greater than the minimum scaling value. The square root will not be found if the maximum is smaller than the minimum. Note 2 When the square root function is used, set the scaling values after square root calculation (e.g., for flow rates or other values) for the process value scaling A and B settings. |
| | Adjustment period control | When zero/span adjustment is executed, the date is internally recorded at the Unit. When the preset zero/span adjustment period and the notice of days remaining set in the Expansion Setting Area have elapsed, this function turns ON a warning flag to give notice that it is time for readjustment. |
| | Peak and bottom detection | Detects the maximum (peak) and minimum (bottom) analog input values, from when the Hold Start Bit (output) allocated to the Expansion Control/Monitor Area turns ON until it turns OFF. These values are stored as the peak and bottom values in the Expansion Control/Monitor Area. |
| | Top and valley detection | This function detects the top and valley values for analog inputs, from when the Hold Start Bit (output) allocated to the Expansion Control/Monitor Area turns ON until it turns OFF. These values are stored as the top and valley values in the Expansion Control/Monitor Area. |
| Integral value calculation | | This function calculates the analog input value's time integral. The integral value is calculated and output to the Expansion Control/Monitor Area when the Integral Value Calculation Start Bit in the Expansion Control/Monitor Area is turned ON. |
| Isolation | | Between inputs and between inputs and PLC signals: Isolation by transformer and photocoupler. |
| Insulation resistance | | 20 M Ω (at 500 V DC) between all inputs |
| Dielectric strength | | Between inputs: 1,000 V AC, at 50/60 Hz, for 1 min, leakage current 10 mA max. |
| External connections | | Terminal block (detachable) |
| Unit number settings | | Set by rotary switches on front panel, from 0 to 95. |
| Indicators | | Four LED indicators on front panel (for normal operation, errors detected at the Direct Current Input Unit, and errors detected at the CPU Unit). |
| Front panel connector | | Sensor input connector terminal block (detachable) |
| Effect on CPU Unit cycle time | | 0.3 ms |
| Current consumption | | 5 V DC at 180 mA max. |
| External power supply | | 24 V DC +10%/-15% 90 mA max., inrush current: 20 A for 1 ms max. (The external 24-VDC power supply must be isolated.) |
| Dimensions | | 31 × 130 × 65 mm (W × H × D) |
| Weight | | 150 g max. |
| Standard accessories | | Short bars (for current input) |

Accuracy and Resolution in ± 10 -V User-set Range

The ± 10 -V user-set range allows the input signal's input range to be set to any range within -10.000 V to 10.000 V. Accuracy and resolution, however, are not determined by the input range, but rather by the measurable input range (-10.000 V to 10.000 V). Therefore, accuracy and resolution do not change even if a narrow input range is set.

DM Area Allocations

First word: word m. $m = D20000 + \text{unit number} \times 100$ (unit number: 0 to 95)

| DM Area address | | Data range | | Default | Data contents |
|--|-------------|-----------------|------------------------------------|------------------|--|
| Input No. 1 | Input No. 2 | Decimal | Hexadecimal | | |
| m | | 12345, 0 | 3039, 0000 hex | 0000 hex | Default block read command Specifies the direction of data transfer when the PLC is turned ON or the Unit is restarted for DM Area words m+1 to m+93. <ul style="list-style-type: none"> 12345 (3039 hex): The data in words m+1 to m+93 is transferred from the Direct Current Input Unit to the CPU Unit. When the transfer is completed, the value will become 0000 hex. Other than 12345 (such as 0000 hex): The data in the allocated words of DM Area is transferred from the CPU Unit to the Direct Current Input Unit. |
| m+1 | | --- | --- | 0 (0000 hex) | Not used. |
| Setting Group 1 (continuously refreshed area): Parameters that are continuously refreshed during PLC operation (regardless of the CPU Unit's operation mode) | | | | | |
| | | | | | Process value alarm settings |
| m+2 | m+10 | -32768 to 32767 | 8000 to FFFF hex, 0000 to 7FFF hex | 4200 (1068 hex) | Process value HH (high high limit) alarm setting (Set at process value scaling value.) |
| m+3 | m+11 | -32768 to 32767 | 8000 to FFFF hex, 0000 to 7FFF hex | 4000 (0FA0 hex) | Process value H (high limit) alarm setting (Set at process value scaling value.) |
| m+4 | m+12 | -32768 to 32767 | 8000 to FFFF hex, 0000 to 7FFF hex | 0 (0000 hex) | Process value L (low limit) alarm setting (Set at process value scaling value.) |
| m+5 | m+13 | -32768 to 32767 | 8000 to FFFF hex, 0000 to 7FFF hex | -200 (FF38 hex) | Process value LL (low low limit) alarm setting (Set at process value scaling value.) |
| | | | | | Rate-of-change value alarm settings |
| m+6 | m+14 | -32768 to 32767 | 8000 to FFFF hex, 0000 to 7FFF hex | 4000 (0FA0 hex) | Rate-of-change value H (high limit) alarm setting (Set at rate-of-change scaling value.) |
| m+7 | m+15 | -32768 to 32767 | 8000 to FFFF hex, 0000 to 7FFF hex | 0 (0000 hex) | Rate-of-change value L (low limit) alarm setting (Set at rate-of-change scaling value.) |
| | | | | | Zero/span adjustment |
| m+8 | m+16 | 0 to 32000 | 0000 to 7D00 hex | 10000 (2710 hex) | Gain for span adjustment (set value \times 0.0001%) |
| m+9 | m+17 | -32000 to 32000 | 8300 to FFFF hex, 0000 to 7D00 hex | 0 (0000 hex) | Zero adjustment value (Set at process value scaling value.) |
| Setting Group 2 (initial settings area): Parameters that are transferred one time from the CPU Unit to the Direct Current Input Unit if word m contains other than 12345 when the PLC is turned ON or the Direct Current Input Unit is restarted. | | | | | |
| | | | | | Input signal type |
| m+34 | m+48 | 0 to 9 | 0000 to 0009 hex | 1 (0001 hex) | 0: ± 10 V; 1: 0 to 10 V; 2: ± 5 V; 3: 0 to 5 V; 4: 1 to 5 V; 5: 4 to 20 mA; 6: ± 10 V user-set range; 7: 0 to 20 mA; 8: ± 1.25 V; 9: 0 to 1.25 V |
| | | | | | Process value input range |
| m+35 | m+49 | -1000 to 1000 | D8F0 to FFFF hex, 0000 to 2710 hex | 10000 (2710 hex) | ± 10 -V user-set range Maximum value in range (set value \times 0.001 V) |
| m+36 | m+50 | -1000 to 1000 | D8F0 to FFFF hex, 0000 to 2710 hex | 0 (0000 hex) | Minimum value in range (set value \times 0.001 V) |

| DM Area address | | Data range | | Default | Data contents | |
|---|-------------|---------------------|------------------------------------|------------------|---|--|
| Input No. 1 | Input No. 2 | Decimal | Hexadecimal | | | |
| | | | | | Square root function | |
| m+37 | m+51 | 0, 1 | 0000, 0001 hex | 0 (0000 hex) | Square root extraction (when maximum scaling value > minimum scaling value) 0: Disable; 1: Enable | |
| | | | | | Process value scaling | |
| m+38 | m+52 | -32000 to 32000 | 8300 to FFFF hex, 0000 to 7D00 hex | 4000 (0FA0 hex) | Value stored for maximum value in range (span) | |
| m+39 | m+53 | -32000 to 32000 | 8300 to FFFF hex, 0000 to 7D00 hex | 0 (0000 hex) | Value stored for minimum value in range (zero) | |
| | | | | | Alarm supplementary functions | |
| m+40 | m+54 | 0 to 32000 | 0000 to 7D00 hex | 40 (0028 hex) | Alarm hysteresis (Set at process value scaling value. Shared with process value alarm and rate-of-change alarm.) | |
| m+41 | m+55 | 0 to 60 | 0000 to 003C hex | 0 (0000 hex) | Alarm ON-delay time (Unit: s) (Shared with process value alarm and rate-of-change alarm.) | |
| | | | | | Rate-of-change function | |
| m+42 | m+56 | -32000 to 32000 | 8300 to FFFF hex, 0000 to 7D00 hex | 4000 (0FA0 hex) | Rate-of-change range setting | Maximum rate-of-change value (Process value industrial unit; comparison time interval) |
| m+43 | m+57 | -32000 to 32000 | 8300 to FFFF hex, 0000 to 7D00 hex | -4000 (F060 hex) | | Minimum rate-of-change value (Process value industrial unit; comparison time interval) |
| m+44 | m+58 | 1 to 16 | 0001 to 0010 hex | 1 (0001 hex) | Rate-of-change comparison time interval (Unit: s) | |
| m+45 | m+59 | -32000 to 32000 | 8300 to FFFF hex, 0000 to 7D00 hex | 4000 (0FA0 hex) | Rate-of-change value scaling | Value stored for maximum value in range |
| m+46 | m+60 | -32000 to 32000 | 8300 to FFFF hex, 0000 to 7D00 hex | -4000 (F060 hex) | | Value stored for minimum value in range |
| | | | | | Mean value processing function | |
| m+47 | m+61 | 1 to 128 | 0001 to 0080 hex | 25 (0019 hex) | Number of process values for calculating moving average for mean value processing | |
| Display parameter | | | | | | |
| m+90 | m+91 | 0 to 99, 100 to 1XX | 0000 to 0063 hex, 0064 to 0XXX hex | 0 (0000 hex) | Address of Data Range Error (See note.) | |
| Expansion Setting Area Allocation Settings | | | | | | |
| m+98 | | 0 to 5 | 0000 to 0005 hex | --- | Area of Expansion Setting Area 0: Not used; 1: DM; 2: CIO; 3: W; 4: H; 5: EM | |
| m+99 | | 0 to 32767 | 0000 to 7FFF hex | --- | First Word in Expansion Setting Area | |

- Note**
- The ERC indicator on the Unit's front panel will light if an out-of-range setting is made in either Setting Group 1 (continually refreshed area) or 2 (initial settings area), or in the Expansion Setting Area. The offset from word m to the first address containing the out-of-range error will be stored as the Address of Data Range Error in the DM Area in four digits hexadecimal.
If the first memory address where the out-of-range error occurred is in the Expansion Setting Area, the Address of Data Range Area will be +100 or later. If the first word of the Expansion Setting Area has the error, the Address of Data Range Area will be +100.
 - When specifying an expansion setting area, be sure that it does not overlap with other areas that are being used. If areas overlap, the words that are allocated may be overwritten, resulting in unexpected operation.
 - When specifying the first word in an expansion setting area, be sure that the end of the memory area is not exceeded.

Expansion Setting Area Allocations

First word: word o. o = address specified in word m+99 in the area specified by word m+98 in the DM Area.

| DM Area address | | Data range | | Default | Data contents |
|--|-------------|-----------------|------------------------------------|------------------|--|
| Input No. 1 | Input No. 2 | Decimal | Hexadecimal | | |
| Setting Group 3 (initial settings area): Parameters that are transferred one time from the CPU Unit to the Direct Current Input Unit if word m contains other than 12345 when the PLC is turned ON or the Direct Current Input Unit is restarted. | | | | | |
| | | | | | Expansion Control/Monitor Area Settings |
| o | | 0 to 5 | 0000 to 0005 hex | --- | Expansion Control/Monitor Area allocation 0: Not used. 1: DM; 2: CIO; 3: W; 4: H; 5: EM |
| o+1 | | 0 to 32767 | 0000 to 7FFF hex | --- | Expansion Control/Monitor Area first word |
| | | | | | Zero/span adjustment supplementary function |
| o+2 | o+13 | 0 to 32000 | 0000 to 7D00 hex | 10000 (2710 hex) | Span adjustment position (Input span percentage) |
| o+3 | o+14 | -32000 to 32000 | 8300 to FFFF hex, 0000 to 7D00 hex | 0 (0000 hex) | Zero adjustment position (Input span percentage) |
| o+4 | o+15 | 0 to 9999 | 0000 to 270F hex | 365 (016D hex) | Zero/span adjustment period (Unit: Days) |
| o+5 | o+16 | 0 to 9999 | 0000 to 270F hex | 30 (001E hex) | Notice of days remaining (Unit: Days) |
| | | | | | Not used |
| o+6 | o+17 | --- | --- | 0 (0000 hex) | Not used |
| o+7 | o+18 | | | | |
| o+8 | o+19 | | | | |
| | | | | | Top and valley hold |
| o+9 | o+20 | 0 to 32000 | 0000 to 7D00 hex | 40 (0028 hex) | Hysteresis |
| | | | | | Integral value calculation |
| o+10 | o+21 | 0, 1 | 0000, 0001 hex | 0 (0000 hex) | Integer unit 0: Minutes; 1: Hours |
| | | | | | Not used |
| o+11 | o+22 | --- | --- | 0 (0000 hex) | Not used. |
| o+12 | o+23 | | | | |

- Note**
1. When specifying an expansion control/monitor area be sure that it does not overlap with other areas that are being used. If areas overlap, the words that are allocated may be overwritten, resulting in unexpected operation.
 2. When specifying the first word in an expansion control/monitor area be sure that the end of the memory area is not exceeded.

CIO Area AllocationsFirst word: word n. $n = 2000 + \text{unit number} \times 10$ (unit number: 0 to 95)

| Direction | Word | Bit | Name | Data range | Contents | |
|---------------------------------------|----------|-----------|----------------------------------|--|---|--|
| Direct Current Input Unit to CPU Unit | n | 00 | Input No. 1 | Process value LL (low low limit) alarm | 0, 1 | 0: Process value > Set value 1: Process value ≤ Set value |
| | | 01 | | Process value L (low limit) alarm | 0, 1 | |
| | | 02 | | Process value H (high limit) alarm | 0, 1 | 0: Process value < Set value 1: Process value ≥ Set value |
| | | 03 | | Process value HH (high high limit) alarm | 0, 1 | |
| | | 04 | Input No. 2 | Process value LL (low low limit) alarm | 0, 1 | Same as for input No. 1. |
| | | 05 | | Process value L (low limit) alarm | 0, 1 | |
| | | 06 | | Process value H (high limit) alarm | 0, 1 | |
| | | 07 | | Process value HH (high high limit) alarm | 0, 1 | |
| | 08 to 15 | Not used. | | 0 | Not used. | |
| | n+1 | 0 to 15 | Input No. 1 process value | | -32768 to 32767 (8000 to FFFF hex, 0000 to 7FFF hex) | The present process value is stored according to the scaling set in the allocated words of the DM Area. |
| | n+2 | 0 to 15 | Input No. 2 process value | | | |
| | n+3, n+4 | --- | Not used. | | 0000 | Not used. |
| | n+5 | 0 to 15 | Input No. 1 rate-of-change value | | -32768 to 32767 (8000 to FFFF hex, 0000 to 7FFF hex) | The present rate-of-change value is stored according to the scaling set in the allocated words of the DM Area. |
| | n+6 | 0 to 15 | Input No. 2 rate-of-change value | | | |
| | n+7, n+8 | --- | Not used. | | 0000 | Not used. |

| Direction | Word | Bit | Name | | Data range | Contents |
|--|------|----------|------------------------------------|---|------------|--|
| Direct Current Input Unit to CPU Unit, continued | n+9 | 00 | Input No. 1 | Rate-of-change value L (low limit) alarm | 0, 1 | 0: Rate-of-change value > set value 1: Rate-of-change value ≤ set value |
| | | 01 | | Rate-of-change value H (high limit) alarm | | 0: Rate-of-change value < set value 1: Rate-of-change value ≥ set value |
| | | 02 | Input No. 2 | Rate-of-change value L (low limit) alarm | 0, 1 | Same as for input No. 1. |
| | | 03 | | Rate-of-change value H (high limit) alarm | | |
| | | 04 to 07 | Not used. | | 0 | Not used. |
| | | 08 | Input No. 1 input error | | 0, 1 | 0: Normal 1: Error (less than -17.2% or greater than 112.5%) Note Checks are conducted for inputs of 4 to 20 mA and 1 to 5 V. |
| | | 09 | Input No. 2 input error | | | |
| | | 10 to 12 | Not used. | | 0 | Not used. |
| | | 13 | Zero/span adjustment period end | | 0, 1 | 0: Adjustment enabled 1: Adjustment ended |
| | | 14 | Zero/span adjustment period notice | | | |
| | | 15 | External power supply | | 0, 1 | 0: External power supply not used 1: External power supply used |

Note The External Power Supply Flag turns ON after external power is supplied and the internal voltage stabilizes (which requires approximately 2 s). The indicator on the front of the Unit will turn ON as soon as external power is supplied.

Expansion Control/Monitor Area Allocations

First word: p. p = address specified in word o+1 in the area specified by word o in the Expansion Setting Area.

| Direction | Word | Bit | Name | Data range | Contents |
|--|----------|----------|--|--|--|
| CPU Unit to Direct Current Input Unit, continued | p | 00 to 15 | Not used. | 0000 | Not used. |
| | p+1 | 00 | Input No. 1 hold function selection | 0, 1 | 0: Peak and bottom 1: Top and valley |
| | | 01 | Input No. 2 hold function selection | 0, 1 | |
| | | 02 to 07 | Not used. | 0 | Not used. |
| | | 08 | Input No. 1 hold start | 0, 1 | 0: Do not hold. |
| | | 09 | Input No. 2 hold start | 0, 1 | 1: Hold |
| | | 10, 11 | Not used. | 0 | Not used. |
| | | 12 | Input No. 1 hold value reset | 0, 1 | 0: Normal operation |
| | | 13 | Input No. 2 hold value reset | 0, 1 | 1: Reset hold value. |
| | | 14, 15 | Not used. | 0 | Not used. |
| | | p+2 | 00 | Input No. 1 integral value calculation start | 0, 1 |
| | 01 | | Input No. 2 integral value calculation start | 0, 1 | 1: Start calculation |
| | 02, 03 | | Not used. | 0 | Not used. |
| | 04 | | Input No. 1 integral value reset | 0, 1 | 0: Normal operation |
| | 05 | | Input No. 2 integral value reset | 0, 1 | 1: Integral value reset |
| | 06 to 15 | | Not used. | 0 | Not used. |
| | p+3 | 00 | Input No. 1 zero/span adjustment update bit | 0, 1 | 0: Normal operation |
| | | 01 | Input No. 2 zero/span adjustment update bit | 0, 1 | 1: Update adjustment date (Remains ON while writing external FROM.) |
| | | 02 to 15 | Not used. | 0 | Not used. |

| Direction | Word | Bit | Name | | Data range | Contents |
|---------------------------------------|-------------|---------------------|------------------------------|---|---|---|
| Direct Current Input Unit to CPU Unit | p+4 | 00 | Input No. 1 | Zero/span adjustment period end | 0, 1 | 0: Adjustment enabled. 1: Adjustment period end |
| | | 01 | | Zero/span adjustment period notice | 0, 1 | 0: Adjustment enabled. |
| | | 02 | Input No. 2 | Zero/span adjustment period end | 0, 1 | 1: Notice period in effect. |
| | | 03 | | Zero/span adjustment period notice | 0, 1 | Remains set to 1 if the zero/span adjustment bit has never been ON. |
| | | 04 to 07 | Not used. | | 0 | Not used. |
| | | 08 | External FROM error | | 0, 1 | 0: Normal operation. 1: External FROM error. |
| | | 09 to 15 | Not used. | | 0 | Not used. |
| | p+5 | 00 to 15 | Input No. 1 | Day of final adjustment date | 0100 to 3100 (BCD) | Remains set to FFFF if the zero/span adjustment bit has never been ON. |
| | p+6 | 00 to 15 | | Year and month of final adjustment date | 0001 to 9912 (BCD) | |
| | p+7 | 00 to 15 | Input No. 2 | Day of final adjustment date | 0100 to 3100 (BCD) | |
| | p+8 | 00 to 15 | | Year and month of final adjustment date | 0001 to 9912 (BCD) | |
| | p+9 to p+16 | 00 to 15 | Not used. | | 0000 | Not used. |
| | p+17 | 00 to 15 | Input No. 1 | Peak/top value | -32728 to +32767 (8000 to FFFF hex, 0000 to 7FFF hex) | Counts the number of repetitions of conditional operations set in the Expansion Setting Area. |
| | p+18 | 00 to 15 | | Bottom/valley value | -32728 to +32767 (8000 to FFFF hex, 0000 to 7FFF hex) | The bottom or valley value is stored according to the scaling set in the DM Area. |
| | p+19 | 00 to 15 | Input No. 2 | Peak/top value | -32728 to +32767 (8000 to FFFF hex, 0000 to 7FFF hex) | Same as for Input No. 1. |
| p+20 | 00 to 15 | Bottom/valley value | | -32728 to +32767 (8000 to FFFF hex, 0000 to 7FFF hex) | | |
| p+21 to p+24 | --- | Not used. | | 0 | Not used. | |
| p+25 | 00 to 15 | Input No. 1 | Integral value (lower digit) | -2147483648 to 2147483647 (80000000 to FFFFFFFF hex, 00000000 to 7FFFFFFF hex) | The integral value for the present value is stored according to the scaling set in the DM Area. | |
| p+26 | 00 to 15 | | Integral value (upper digit) | | | |
| p+27 | 00 to 15 | Input No. 2 | Integral value (lower digit) | | | |
| p+28 | 00 to 15 | | Integral value (upper digit) | | | |
| p+29 to p+34 | 00 to 15 | Not used. | | 0000 | Not used. | |

Terminal Connection Diagram

Voltage Inputs

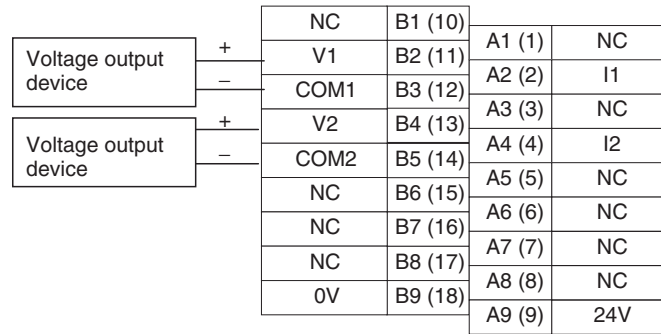

Current inputs

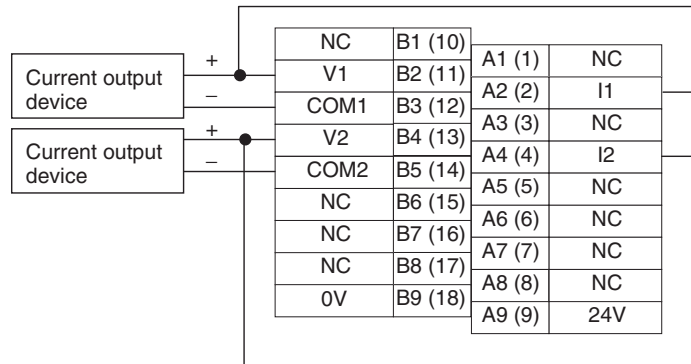

Note

- In both of the above cases, leave all unused inputs open between the positive and negative terminals (e.g., between B2 and B3 for voltage input No. 1).
- Always ground the GR terminal on the Power Supply Unit of the PLC.
- If the input device uses a voltage generator, temperature compensator, or similar device, then ground the input device if it has a ground terminal.
- Always short-circuit the V and I terminals when using current input.

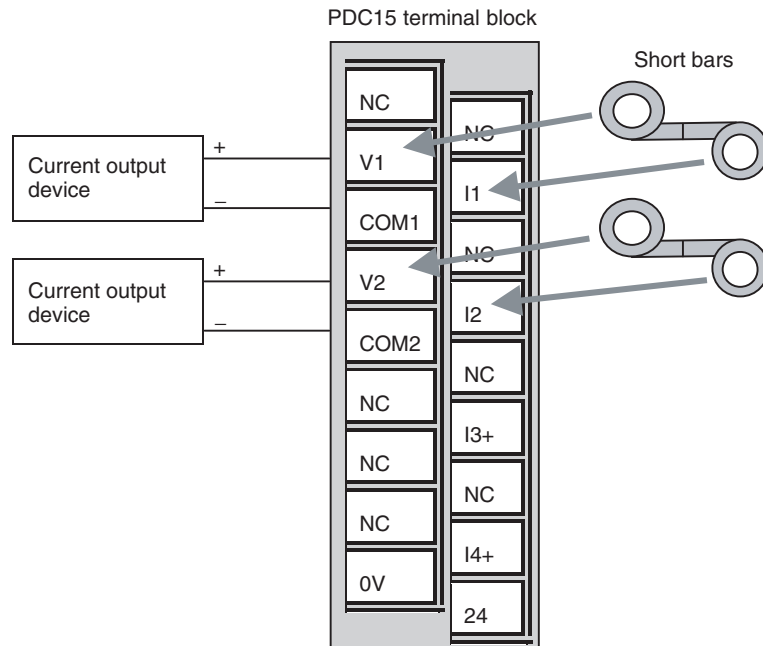

Terminal Block Diagram

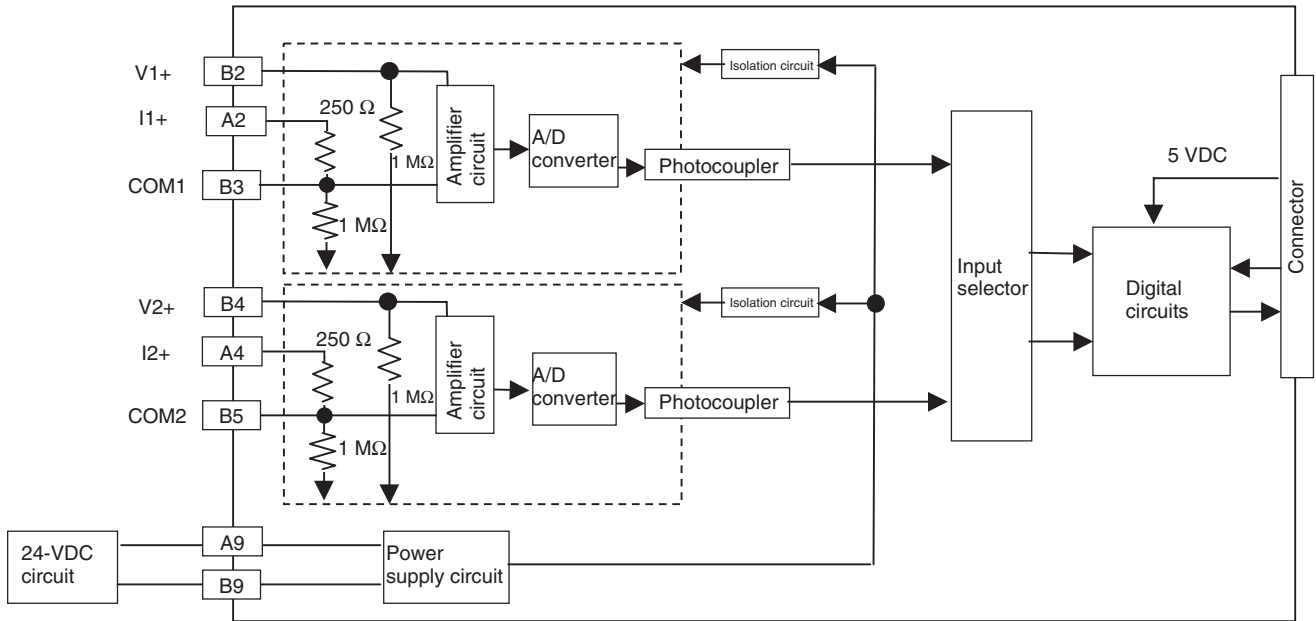

Error Processing

Conversion Data Does Not Change.

| Probable cause | Remedy |
|--|---|
| The gain for span adjustment is set to 0. | Set the gain for span adjustment to a value other than 0. |
| The minimum and maximum values for process value scaling are either the same or are set extremely low. | Set the minimum and maximum values correctly. |
| The input signal type or process value range is set incorrectly. | Check and reset the input signal type and the process value range settings. |
| An input device is malfunctioning, input wiring is faulty, or wiring is disconnected. | Check whether the input voltage or current has changed. Check for faulty or disconnected wiring. Check whether an input error has been detected in the I/O Area. |

Values are Not Converted as Intended.

| Probable cause | Remedy |
|--|---|
| The input signal type or process value scaling is set incorrectly. | Check and reset the input signal type and the process value scaling settings. |
| The zero/span adjustment data is incorrect. | Check and correct the zero/span adjustment settings. |
| The square root function is operating. | Set the square function so that it does not operate. |

Converted Values are Unstable.

| Probable cause | Remedy |
|--|---|
| Input signals are being affected by external noise. | Change the connection paths of the input signal lines. (Separate them from sources of noise or use shielded cable.) |
| | Insert 0.01- μ F to 0.1- μ F ceramic capacitors between the I+ and COM input terminals. |
| | Increase the number of values for calculating the moving average in mean value processing. |
| The scaling value is greater than the Unit's resolution. | Reduce the scaling value. |

3-6 CJ1W-PH41U Isolated-type Universal Input Unit

Overview

The CJ1W-PH41U Isolated-type Universal Input Unit supports four input channels, each of which can be set to a resistance thermometer, thermocouple, DC signal, or potentiometer input. All inputs are isolated.

CJ1W-PH41U

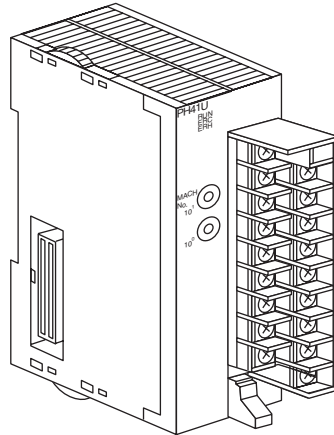

System Configuration

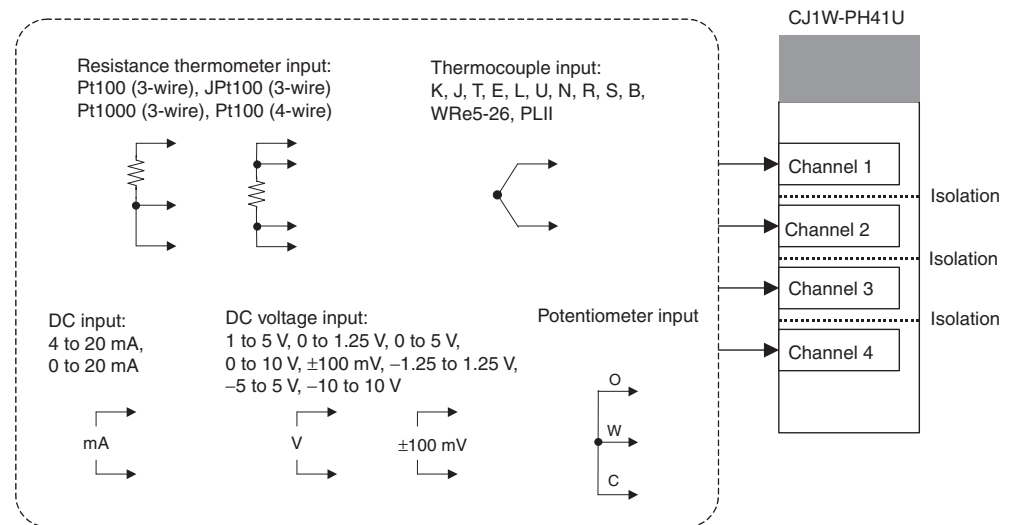

Features

- A single Unit supports a maximum of four inputs: resistance thermometer, thermocouple, DC current/voltage, and potentiometer. The input type is set separately for each input.
Resistance thermometer input Pt100 (JIS, IEC 3-wire), JPt100 (3-wire), Pt1000 (3-wire), or Pt100 (JIS, IEC 4-wire) can be selected.
Thermocouple input K, J, T, E, L, U, N, R, S, B, WRe5-26, or PLII can be selected.
For DC signal, 4 to 20 mA, 0 to 20 mA, 1 to 5 V, 0 to 1.25 V, 0 to 5 V, 0 to 10 V, ± 100 mV, -1.25 to 1.25 V, -5 to 5 V, or -10 to 10 V can be selected.
In addition, a potentiometer input can be selected.
- Isolation between input channels prevents unwanted current paths between input channels.
- A minimum resolution of $1/256,000$ is achieved.
- The conversion period is 60 ms/4 points at a resolution of $1/256,000$, 10 ms/4 points at $1/64,000$ (Pt1000 or a potentiometer input cannot be

selected), and 5 ms/4 points at 1/16,000 (K and E thermocouple inputs only can be selected). The fastest conversion period is automatically set for the resolution.

- Scaled values are transferred to the CPU Unit in eight or four digits hexadecimal.
- Input ranges can be set to any values.
- Process value alarms (four alarms for each point) are provided.
- Alarm ON/OFF delay timer and hysteresis are provided for process values.
- Averaging function is provided.
- Rate-of-change function is provided.
- Rate-of-change alarms (two alarms for each point) are provided.
- Zero/span adjustment during operation is supported.
- Input error detection is supported.
- Process value clamp direction is supported for input burnout.
- Adjustment period control is provided.
- Peak and bottom value detection is supported.
- Top and valley value detection is supported.
- Square root extraction (DC input only) is supported.
- Integral value calculation is supported.

Model Information

| Type of Unit | Model | Number of inputs | Input types |
|----------------------------|------------|------------------|---|
| CJ-series Special I/O Unit | CJ1W-PH41U | 4 | Resistance thermometer: Pt100 (JIS, IEC 3-wire), JPt100 (3-wire), Pt1000 (3-wire), Pt100 (JIS, IEC 4-wire) Thermocouple: K, J, T, E, L, U, N, R, S, B, WRe5-26, PLII Current: 4 to 20 mA, 0 to 20 mA Voltage: 1 to 5 V, 0 to 1.25 V, 0 to 5 V, 0 to 10 V, ± 100 mV, -1.25 to 1.25 V, -5 to 5 V, -10 to 10 V Potentiometer: The input type is set separately for each input. |

Block Diagram (Order of Processing)

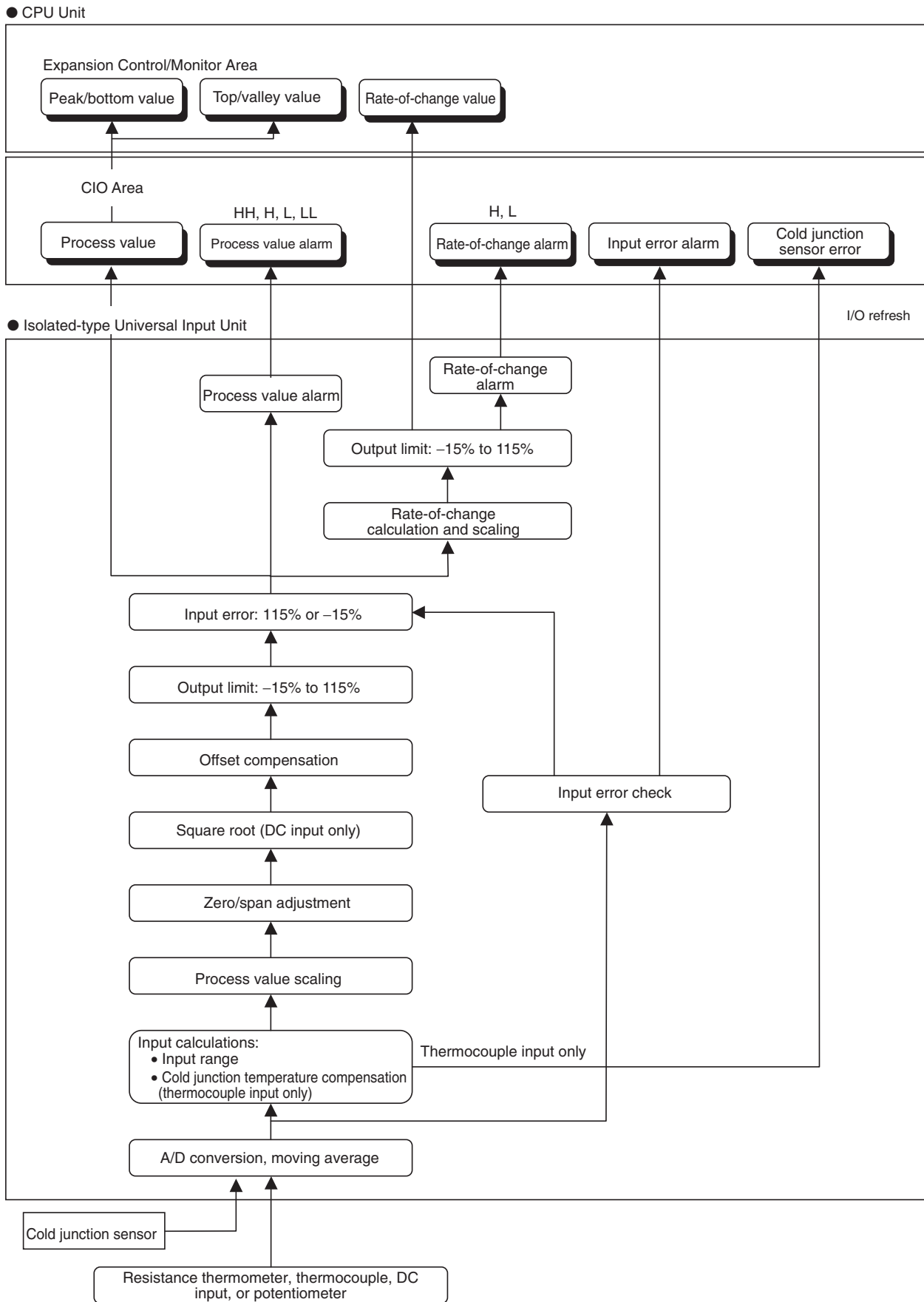

Specifications

| Item | | Specifications |
|---|--|---|
| Model | | CJ1W-PH41U |
| Applicable PLC | | CJ Series |
| Type of Unit | | CJ-series Special I/O Unit |
| Mounting position | | CPU Rack or CJ-series Expansion Rack |
| Maximum number of Units | | 40 (within the allowable current consumption and power consumption range) |
| Unit numbers | | 00 to 95 (Cannot duplicate Special I/O Unit numbers.) |
| Areas for exchanging data with the CPU Unit | Special I/O Unit Area words in the CIO Area | 10 words/Unit Isolated-type Universal Input Unit to CPU Unit: All process values, process value alarms (LL, L, H, HH), rate-of-change alarms (L, H), input errors (such as disconnection alarms), cold junction sensor errors, and zero/span adjustment period end/notices. |
| | Special I/O Unit words in the DM Area | 100 words/Unit CPU Unit to Isolated-type Universal Input Unit: Operation settings, input type, input range (user set), temperature unit, process value clamp direction for input burnout, scaling upper and lower limits, scaling offset value, alarm hysteresis, alarm ON/OFF delay time, number of items for moving average, Expansion Setting Area settings, process value alarm setting (L, H), zero/span adjustment value. |
| | Expansion Control/Monitor Area | 46 words/Unit CPU Unit to Isolated-type Universal Input Unit: Hold function selection start/reset, integral value calculation start/reset, zero/span adjustment period flag Isolated-type Universal Input Unit to CPU Unit: All rate-of-change values, zero/span adjustment period notices (all inputs), EEPROM errors, day of final adjustment date, top and valley detection flags, peak and bottom values, top and valley values, integral value. |
| | Expansion Setting Area | 100 words/Unit CPU Unit to Isolated-type Universal Input Unit: Expansion Control/Monitor Area settings, square root calculation enable, rate-of-change input range, rate-of-change comparison time interval, rate-of-change scaling upper and lower limits, zero/span adjustment position, zero/span adjustment period and notice of days remaining, top and valley hysteresis, integral value calculation integer unit and integer coefficient, temperature resistance thermometer compensation enable, temperature resistance thermometer reference resistance, cold junction compensation method, process value alarm settings (LL, HH), rate-of-change alarm settings (L, H). |
| Number of inputs | | 4 |
| Input type | Resolution: 1/256,000 (Conversion period: 60 ms) | Pt100 (JIS, IEC 3-wire), JPt100 (3-wire), Pt1000 (3-wire), Pt100 (JIS, IEC 4-wire), K, J, T, E, L, U, N, R, S, B, WRe5-26, PLII, 4 to 20 mA, 0 to 20 mA, 1 to 5 V, 0 to 1.25 V, 0 to 5 V, 0 to 10 V, ± 100 mV user-set range, -1.25 to 1.25 V, -5 to 5 V, -10 to 10 V, ± 10 V user-set range, potentiometer (all inputs). The input type, input range, and scaling can be set for individual inputs. The input range for DC inputs, however, can be set only for input types with user-set input ranges. |
| | Resolution: 1/64,000 (Conversion period: 10 ms) | Pt100 (JIS, IEC 3-wire), JPt100 (3-wire), Pt100 (JIS, IEC 4-wire), K, J, T, E, L, U, N, R, S, B, WRe5-26, PLII, 4 to 20 mA, 0 to 20 mA, 1 to 5 V, 0 to 1.25 V, 0 to 5 V, 0 to 10 V, ± 100 mV user-set range, -1.25 to 1.25 V, -5 to 5 V, -10 to 10 V, ± 10 V user-set range (all inputs). The input type, input range, and scaling can be set for individual inputs. The input range for DC inputs, however, can be set only for input types with user-set input ranges. |
| | Resolution: 1/16,000 (Conversion period: 5 ms) | K, E |

| Item | Specifications |
|---|--|
| Applicable standards for resistance thermometer and thermocouple inputs | Pt100: JIS C1604-1997, IEC 60751-95 JPt100: JIS C1604-1989 K, J, T, E, N, R, S, B: JIS C1602-1995 L, U: DIN 43710-1985 WRe5-26: ASTM E988-96 PLII: ASTM E1751-00 |
| Scaling | Data to be stored in the allocated words in the CIO area must be scaled (with user-set minimum and maximum values for data and offsets). The inputs are set individually. Data can be converted at 0% to 100%. |
| Data storage in the Special I/O Unit Area in the CIO Area | The values derived from carrying out the following processing in order of the actual process data in the input range are stored in four digits hexadecimal (binary values) in the allocated words in the Special I/O Unit Area. 1) Averaging → 2) Scaling → 3) Zero/span adjustment → 4) Square root calculation → 5) Offset compensation → 6) Output limits |
| Accuracy (25°C) | Resistance thermometer or thermocouple input: ±0.05% (The accuracy depends on the input type and the measured temperature. For details, refer to the <i>Accuracy and Temperature Coefficient According to Resistance Thermometer and Thermocouple Input Types and Measured Temperatures</i> on page 347. Current or voltage input: ±0.05% Potentiometer input: ±1% |
| Temperature coefficient | Resistance thermometer or thermocouple input: The temperature coefficient depends on the input type and the measured temperature. For details, refer to the <i>Accuracy and Temperature Coefficient According to Resistance Thermometer and Thermocouple Input Types and Measured Temperatures</i> on page 347. Current or voltage input: ±80 ppm/°C (for full scale) Potentiometer input: ±100 ppm/°C (for full scale) |
| Cold junction compensation error | Thermocouple input: ±1.2°C |
| Resolution | 1/256,000 (Conversion period: 60 ms) (See note.), 1/64,000 (Conversion period: 10 ms), 1/16,000 (Conversion period: 5 ms) Note: The resolution for a potentiometer input is 1/4,000. |
| Input signal range | Resistance thermometer, thermocouple, ±100 mV user-set input: –15% to 115% of measurable input range 4 to 20 mA, 1 to 5 V, 0 to 1.25 V, 0 to 5 V, 0 to 10 V input: –15% to 115% 0 to 20 mA input: 0% to 115% –1.25 to 1.25 V, –5 to 5 V, –10 to 10 V, ±10 V user-set range input: –7.5% to 107.5% Potentiometer input: –15% to 115% of 0 to 2,500 Ω |
| Influence of lead wire resistance | Resistance thermometer input: 0.06°C/Ω (20 Ω max.) (3-wire) 0.006°C/Ω (20 Ω max.) (4-wire) |
| Input detection current | Resistance thermometer input: Approx. 0.21 mA (3-wire), approx. 0.42 mA (4-wire) Potentiometer input: Approx. 0.21 mA |
| Absolute maximum ratings | Thermocouple, ±100 mV user-set range input: ±130 mV Current input: 30 mA Voltage input (excluding ±100 mV user-set range): ±15 V |
| Input impedance | Thermocouple, ±100 mV user-set range input: 20 kΩ min. Current input: 150 Ω max. Voltage input (excluding ±100 mV user-set range): 1 MΩ min. |
| Input disconnection detection current | Thermocouple, ±100 mV user-set range input: Approx. 0.1 μA |

| Item | Specifications |
|--|---|
| Warmup time | Resistance thermometer input: 30 min Thermocouple, ± 100 mV user-set range input: 45 min Current or voltage input (excluding ± 100 mV user-set range): 30 min Potentiometer input: 10 min |
| Response time | <p>1/256,000 resolution:</p> <p>Resistance thermometer input: 180 ms max. (travel time from input 0% to 90%, for step input and with moving average for 1 sample)</p> <p>Thermocouple, ± 100 mV user-set range input: 180 ms max. (travel time from input 0% to 90%, for ± 100 mV step input and with moving average for 1 sample)</p> <p>Current or voltage input: 180 ms max. (travel time from input 0% to 90%, for ± 10 V step input and with moving average for 1 sample)</p> <p>Potentiometer input: 180 ms max. (travel time from input 0% to 90%, for step input and with moving average for 1 sample)</p> <p>1/64,000 resolution:</p> <p>Resistance thermometer input: 100 ms max. (travel time from input 0% to 90%, for step input and with moving average for 4 samples)</p> <p>Thermocouple, ± 100 mV user-set range input: 100 ms max. (travel time from input 0% to 90%, for ± 100 mV step input and with moving average for 4 samples)</p> <p>Current or voltage input: 100 ms max. (travel time from input 0% to 90%, for ± 10 V step input and with moving average for 4 samples)</p> <p>1/16,000 resolution:</p> <p>Thermocouple input: 100 ms max. (travel time from input 0% to 90%, for ± 100 mV step input and with moving average for 4 samples)</p> |
| Conversion period | 60 ms/4 inputs (1/256,000 resolution), 10 ms/4 inputs (1/64,000 resolution, 5 ms/4 inputs (1/16,000 resolution) |
| Maximum time to store data in CPU Unit | Conversion period + one CPU Unit cycle |

| Item | Specifications |
|---|--|
| Input disconnection and input error detection | <p>Resistance thermometer, thermocouple, ± 100 mV user-set range, potentiometer input:</p> <p>Input Error Flag turns ON when a disconnection occurs or when 115% or -15% of the measurable input range is exceeded. The process value clamp direct direction for when a disconnection occurs can be specified. (High: 115% of set input range. Low: -15% of set input range.) Disconnection detection time: Approx. 5 s max. (4-wire Pt100) Approx. 1 s max. (± 100 mV user-set range) Approx. 0.5 s max. (not 4-wire Pt100 or ± 100 mV user-set range)</p> <p>4 to 20 mA, 1 to 5 V, 0 to 1.25 V, 0 to 5 V, 0 to 10 V input: An error is detected and the Input Error Flag turns ON when a disconnection occurs or when 115% or -15% of the measurable input range is exceeded. When a disconnection occurs in the 4 to 20 mA/1 to 5 V range, the -15% process value is stored. When a disconnection occurs in any other range, a process value the same as for a 0 V input is stored.</p> <p>0 to 20 mA input: An error is detected and the Input Error Flag turns ON when 115% of the measurable input range is exceeded. When a disconnection occurs, a process value the same as for a 0 mA input is stored.</p> <p>-1.25 to 1.25 V, -5 to 5 V, -10 to 10 V, ± 10 V user-set range input: An error is detected and the Input Error Flag turns ON when 107.5% or -7.5% of the measurable input range is exceeded. When a disconnection occurs, a process value the same as for a 0 V input is stored.</p> |

| Item | | Specifications |
|---|--|--|
| Function | Process value alarm | Four process value alarms (HH, H, LL, L), hysteresis, and ON/OFF-delay timer (0 to 60 s) can be set. |
| | Rate-of-change calculation | Calculates the amount of change per process value comparison time interval (Either 1 to 16 s or the conversion period can be set.) |
| | Rate-of-change alarm | Two rate-of-change alarms (H, L), hysteresis, and ON/OFF-delay timer (0 to 60 s) can be set (shared with process value alarm). |
| | Process value averaging (input filter) | Calculates the moving average for the specified number of past process values (1 to 128), and stores that value in the CIO Area as the process value. |
| | Square root extraction | When the process value scaling maximum value is A and the minimum value is B: $Output = \sqrt{(A - B) \times (Input - B)} + B$ Dropout: Output approx. 7% maximum linear (output = input) characteristics Note 1: The square root function is enabled for DC inputs only. It is not performed for temperature inputs. Note 2: The square root function is enabled only when the maximum scaling value is greater than the minimum value. It is not performed when the minimum value is greater. Note 3: When performing square root calculation, set the maximum and minimum scaling values to the scaling values following square root extraction of the flowrate or other input value. |
| | Adjustment period control | When zero/span adjustment is executed, the date is internally recorded at the Unit. When the preset zero/span adjustment period and the notice of days remaining set in the Expansion Setting Area have elapsed, this function turns ON a warning flag to give notice that it is time for readjustment. |
| | Peak and bottom detection | Detects the maximum (peak) and minimum (bottom) process values, from when the Hold Start Bit (output) allocated to the Expansion Control/Monitor Area turns ON until it turns OFF. These values are stored as the peak and bottom values in the Expansion Control/Monitor Area. |
| | Top and valley detection | This function detects the top and valley values for process values, from when the Hold Start Bit (output) allocated to the Expansion Control/Monitor Area turns ON until it turns OFF. These values are stored as the top and valley values in the Expansion Control/Monitor Area. |
| | Integral value calculation | This function calculates the process value's time integral. The integral value is calculated and the result is output to the Expansion Control/Monitor Area when the Integral Value Calculation Start Bit in the Expansion Control/Monitor Area is turned ON. |
| Cold junction compensation method | Specifies whether cold junction compensation is to be executed internally or externally. Note: This function is supported only for thermocouple inputs. | |
| Resistance thermometer input compensation | Compensation is enabled for a connected resistance thermometer by setting the resistance for 23°C. Note: This function is supported only for resistance thermometer inputs. | |
| Isolation | Between inputs and PLC signals, and between inputs: Power supply = Transformer, Signal = Digital isolator | |
| Insulation resistance | 20 MΩ (at 500 V DC) between all inputs | |
| Dielectric strength | Between all inputs: 500 V AC, at 50 or 60 Hz, for 1 min, leakage current 10 mA max. | |
| External connections | Terminal block (detachable) | |
| Unit number settings | Set by rotary switches on front panel, from 0 to 95. | |
| Indicators | Three LED indicators on front panel (for normal operation, errors detected at the Universal Input Unit, and errors detected at the CPU Unit). | |
| Front panel connector | Input connector terminal block (detachable) | |
| Effect on CPU Unit cycle time | 0.4 ms | |
| Current consumption (supplied by Power Supply Unit) | 5 VDC at 300 mA max. | |
| Dimensions | 31 × 90 × 65 mm (W × H × D) | |

| Item | Specifications |
|----------------------|--|
| Weight | 150 g max. |
| Standard accessories | One cold junction sensor (mounted to terminal block) |

Input Types and Input Ranges

The input type and range are set in the DM Area for each input. Each input range can be set within the measurable input range shown in the following table. (DC input ranges are user-set.) The accuracy and resolution are determined by the measurable input ranges shown in the table, and not by the set input ranges. The accuracy and resolution are not changed by narrowing the input range.

■ Resolution: 1/256,000

| Input type | DM Area settings | Measurable input range |
|------------------------|------------------|------------------------|
| Pt100 (3-wire) | 0 | -200.00 to 850.00°C |
| JPt100 (3-wire) | 3 | -200.00 to 500.00°C |
| Pt1000 (3-wire) | 7 | -200.00 to 850.00°C |
| Pt100 (4-wire) | 9 | -200.00 to 850.00°C |
| | 10 | 0.000 to 50.000°C |
| K | 15 | -200.0 to 1300.0°C |
| | 16 | -20.00 to 600.00°C |
| J | 17 | -200.0 to 1200.0°C |
| | 18 | -20.00 to 600.00°C |
| T | 19 | -200.00 to 400.00°C |
| E | 20 | -200.0 to 1000.0°C |
| L | 21 | -200.0 to 900.0°C |
| U | 22 | -200.0 to 600.0°C |
| N | 23 | -200.0 to 1300.0°C |
| R | 24 | -50.0 to 1700.0°C |
| S | 25 | -50.0 to 1700.0°C |
| B | 26 | 0.0 to 1800.0°C |
| WRe5-26 | 27 | 0.0 to 2300.0°C |
| PLII | 28 | 0.0 to 1300.0°C |
| 4 to 20 mA | 30 | 4 to 20 mA |
| 0 to 20 mA | 31 | 0 to 20 mA |
| 1 to 5 V | 32 | 1 to 5 V |
| 0 to 1.25 V | 34 | 0 to 1.25 V |
| 0 to 5 V | 35 | 0 to 5 V |
| 0 to 10 V | 36 | 0 to 10 V |
| ±100 mV user-set range | 37 | -100 to 100 mV |
| ±1.25 V | 38 | -1.25 to 1.25 V |
| ±5 V | 39 | -5 to 5 V |
| ±10 V | 40 | -10 to 10 V |
| ±10 V user-set range | 41 | -10 to 10 V |
| Potentiometer | 50 | 0 to (100 to 2500) Ω |

■ Resolution: 1/64,000

| Input type | DM Area settings | Measurable input range |
|------------------------|------------------|------------------------|
| Pt100 (3-wire) | 0 | -200.00 to 850.00°C |
| JPt100 (3-wire) | 3 | -200.00 to 500.00°C |
| Pt100 (4-wire) | 9 | -200.00 to 850.00°C |
| K | 15 | -200.0 to 1300.0°C |
| J | 17 | -200.0 to 1200.0°C |
| T | 19 | -200.00 to 400.00°C |
| E | 20 | -200.0 to 1000.0°C |
| L | 21 | -200.0 to 900.0°C |
| U | 22 | -200.0 to 600.0°C |
| N | 23 | -200.0 to 1300.0°C |
| R | 24 | -50.0 to 1700.0°C |
| S | 25 | -50.0 to 1700.0°C |
| B | 26 | 0.0 to 1800.0°C |
| WRe5-26 | 27 | 0.0 to 2300.0°C |
| PLII | 28 | 0.0 to 1300.0°C |
| 4 to 20 mA | 30 | 4 to 20 mA |
| 0 to 20 mA | 31 | 0 to 20 mA |
| 1 to 5 V | 32 | 1 to 5 V |
| 0 to 1.25 V | 34 | 0 to 1.25 V |
| 0 to 5 V | 35 | 0 to 5 V |
| 0 to 10 V | 36 | 0 to 10 V |
| ±100 mV user-set range | 37 | -100 to 100 mV |
| ±1.25 V | 38 | -1.25 to 1.25 V |
| ±5 V | 39 | -5 to 5 V |
| ±10 V | 40 | -10 to 10 V |
| ±10 V user-set range | 41 | -10 to 10 V |

■ Resolution: 1/16,000

| Input type | DM Area settings | Measurable input range |
|------------|------------------|------------------------|
| K | 15 | -200.0 to 1300.0°C |
| E | 20 | -200.0 to 1000.0°C |

Accuracy and Temperature Coefficient According to Resistance Thermometer and Thermocouple Input Types and Measured Temperatures

| Input classification | | Measured temperature (°C) | Standard accuracy °C (%) | Temperature coefficient (See note 1.) °C/°C (ppm/°C) (See note 2.) |
|-------------------------|------------------------|---------------------------|--------------------------|--|
| Temperature sensor type | Temperature range (°C) | | | |
| Pt100 (3-wire) | -200.00 to 850.00 | -200.00 to -50.00 | ±0.5°C (±0.05%) | ±0.08°C/°C (±78ppm/°C) |
| | | -50.00 to 150.00 | ±0.21°C (±0.02%) | ±0.03°C/°C (±29ppm/°C) |
| | | 150.00 to 850.00 | ±0.5°C (±0.05%) | ±0.08°C/°C (±78ppm/°C) |
| JPt100 (3-wire) | -200.00 to 500.00 | Same as on the left. | ±0.4°C (±0.05%) | ±0.07°C/°C (±96ppm/°C) |
| Pt1000 (3-wire) | -200.00 to 850.00 | Same as on the left. | ±0.5°C (±0.05%) | ±0.09°C/°C (±85ppm/°C) |
| Pt100 (4-wire) | -200.00 to 850.00 | Same as on the left. | ±0.5°C (±0.05%) | ±0.02°C/°C (±17ppm/°C) |
| | 0.000 to 50.000 | Same as on the left. | ±0.025°C (±0.05%) | ±0.005°C/°C (±90ppm/°C) |
| K | -200.0 to 1300.0 | Same as on the left. | ±0.75°C (±0.05%) | ±0.08°C/°C (±50ppm/°C) |
| | -20.00 to 600.00 | Same as on the left. | ±0.3°C (±0.05%) | ±0.03°C/°C (±48ppm/°C) |

| Input classification | | Measured temperature (°C) | Standard accuracy °C (%) | Temperature coefficient (See note 1.) °C/°C (ppm/°C) (See note 2.) |
|-------------------------|------------------------|---------------------------|--------------------------|--|
| Temperature sensor type | Temperature range (°C) | | | |
| J | -200.0 to 1200.0 | -200.0 to 0.0 | ±0.7°C (±0.05%) | ±0.13°C/°C (±96ppm/°C) |
| | | 0.0 to 1200.0 | | |
| | -20.00 to 600.00 | Same as on the left. | ±0.3°C (±0.05%) | ±0.04°C/°C (±72ppm/°C) |
| T | -200.00 to 400.00 | -200.00 to -180.00 | ±1.3°C (±0.22%) | ±0.05°C/°C (±75ppm/°C) |
| | | -180.00 to 0.00 | ±0.7°C (±0.12%) | |
| | | 0.00 to 400.00 | ±0.33°C (±0.055%) | |
| E | -200.0 to 1000.0 | -200.0 to 0.0 | ±0.6°C (±0.05%) | ±0.12°C/°C (±100ppm/°C) |
| | | 0.0 to 1000.0 | | ±0.06°C/°C (±50ppm/°C) |
| L | -200.0 to 900.0 | Same as on the left. | ±0.5°C (±0.05%) | ±0.04°C/°C (±40ppm/°C) |
| U | -200.0 to 600.0 | -200.0 to -100.0 | ±0.7°C (±0.09%) | ±0.06°C/°C (±75ppm/°C) |
| | | -100.0 to 0.0 | ±0.5°C (±0.07%) | |
| | | 0.0 to 600.0 | ±0.4°C (±0.05%) | |
| N | -200.0 to 1300.0 | -200.0 to -150.0 | ±1.6°C (±0.11%) | ±0.11°C/°C (±70ppm/°C) |
| | | -150.0 to -100.0 | ±0.75°C (±0.05%) | ±0.08°C/°C (±50ppm/°C) |
| | | -100.0 to 1300.0 | | |
| R | -50.0 to 1700.0 | -50.0 to 0.0 | ±3.2°C (±0.19%) | ±0.13°C/°C (±77ppm/°C) |
| | | 0.0 to 100.0 | ±2.5°C (±0.15%) | ±0.11°C/°C (±60ppm/°C) |
| | | 100.0 to 1700.0 | ±1.75°C (±0.1%) | |
| S | -50.0 to 1700.0 | -50.0 to 0.0 | ±3.2°C (±0.19%) | ±0.13°C/°C (±77ppm/°C) |
| | | 0.0 to 100.0 | ±2.5°C (±0.15%) | ±0.11°C/°C (±60ppm/°C) |
| | | 100.0 to 1700.0 | ±1.75°C (±0.1%) | |
| B | 0.0 to 1800.0 | 0.0 to 400.0 | May not be accurate. | May not be accurate. |
| | | 400.0 to 800.0 | ±3°C (±0.17%) | ±0.12°C/°C (±66ppm/°C) |
| | | 800.0 to 1800.0 | ±1.8°C (±0.1%) | |
| WRe5-26 | 0.0 to 2300.0 | 0.0 to 1500.0 | ±1.15°C (±0.05%) | ±0.13°C/°C (±58ppm/°C) |
| | | 1500.0 to 2200.0 | | ±0.21°C/°C (±91ppm/°C) |
| | | 2200.0 to 2300.0 | ±1.4°C (±0.07%) | |
| PLII | 0.0 to 1300.0 | Same as on the left. | ±0.65°C (±0.05%) | ±0.07°C/°C (±57ppm/°C) |

- Note**
1. Error in process value when ambient temperature changes by 1°C.
 2. For full-scale.

DM Area Allocations

First word: word m. m = D20000 + unit number × 100 (unit number: 0 to 95)

| DM Area address | | | | Data range | | Default | Data contents | |
|--|-------------|-------------|-------------|---------------------------|--|-------------------------------------|---|--|
| Input No. 1 | Input No. 2 | Input No. 3 | Input No. 4 | Decimal | Hexadecimal | | | |
| m | | | | 12345, 0 | 3039 hex, 0000 hex | 0 (0000 hex) | Default Block Read Command Specifies the direction of data transfer when the PLC is turned ON or the Unit is restarted. <ul style="list-style-type: none"> • 12345 (3039 hex): The initial settings for the Analog I/O Unit are transferred from the Analog I/O Unit to words m+1 to m+93 in the CPU Unit. When the transfer is completed, the value will become 0000 hex. • Other than 12345 (3039 hex), such as 0 (0000 hex): The data in the allocated words of DM Area is transferred from the CPU Unit to the Analog Input Unit. | |
| | | | | | | | Operation Settings (See note 1.) | |
| m+1 | | | | (See note 1.) | (See note 1.) | 0 (0000 hex) | Bits 00 to 03: Resolution Switch Bits 04 to 07: Process Value Data Length | |
| Setting Group 1 (continuously refreshed area): Parameters that are continuously refreshed during PLC operation (can be set regardless of the CPU Unit's operation mode) | | | | | | | | |
| | | | | | | Process value alarm settings | | |
| m+2 | m+10 | m+18 | m+26 | -2147483648 to 2147483647 | 80000000 to FFFFFFFF hex, 00000000 to 7FFFFFFF hex | 40000 (00009C40 hex) | Lower | Process Value H (High Limit) Alarm Setting (Set to process value scaling value.) |
| m+3 | m+11 | m+19 | m+27 | | | | Upper | |
| m+4 | m+12 | m+20 | m+28 | -2147483648 to 2147483647 | 80000000 to FFFFFFFF hex, 00000000 to 7FFFFFFF hex | 0 (00000000 hex) | Lower | Process Value L (Low Limit) Alarm Setting (Set to process value scaling value.) |
| m+5 | m+13 | m+21 | m+29 | | | | Upper | |
| | | | | | | Zero/span adjustment | | |
| m+6 | m+14 | m+22 | m+30 | 1 to 100000000 | 00000001 to 05F5E100 hex | 1000000 (00989680 hex) | Lower | Gain for Span Adjustment (set value × 0.0000001% (10 ⁻⁷)%) |
| m+7 | m+15 | m+23 | m+31 | | | | Upper | |
| m+8 | m+16 | m+24 | m+32 | -2147483648 to 2147483647 | 80000000 to FFFFFFFF hex, 00000000 to 7FFFFFFF hex | 0 (00000000 hex) | Lower | Zero Adjustment Value (Set to process value scaling value.) |
| m+9 | m+17 | m+25 | m+33 | | | | Upper | |

| DM Area address | | | | Data range | | Default | Data contents |
|--|-------------|-------------|-------------|-----------------|--------------------------------------|---------------------|--|
| Input No. 1 | Input No. 2 | Input No. 3 | Input No. 4 | Decimal | Hexadecimal | | |
| Setting Group 2 (initial settings area): Parameters that are transferred one time from the CPU Unit to the Analog Input Unit if word m contains other than 12345 when the PLC is turned ON or the Analog Input Unit is restarted. | | | | | | | |
| | | | | | | | Input Signal Type |
| m+34 | m+49 | m+64 | m+79 | 0 to 50 | 0 to 32 hex | 36 (0024 hex) | <ul style="list-style-type: none"> When the Resolution Switch Is Set to 0 (1/256,000) 0: Pt100, 3-wire, 3: JPt100, 3-wire, 7: Pt1000, 3-wire, 9: Pt100, 4-wire (1), 10: Pt100, 4-wire (2), 15: K (1), 16: K (2), 17: J (1), 18: J (2), 19: T, 20: E, 21: L, 22: U, 23: N, 24: R, 25: S, 26: B, 27: WRe5-26, 28: PLII, 30: 4 to 20 mA, 31: 0 to 20 mA, 32: 1 to 5 V, 34: 0 to 1.25 V, 35: 0 to 5 V, 36: 0 to 10 V, 37: ±100 mV user-set range, 38: ±1.25 V, 39: ±5 V, 40: ±10 V, 41: ±10 V user-set range, 50: Potentiometer When the Resolution Switch Is Set to 1 (1/64,000) 0: Pt100, 3-wire, 3: JPt100, 3-wire, 9: Pt100, 4-wire (1), 15: K (1), 17: J (1), 19: T, 20: E, 21: L, 22: U, 23: N, 24: R, 25: S, 26: B, 27: WRe5-26, 28: PLII, 30: 4 to 20 mA, 31: 0 to 20 mA, 32: 1 to 5 V, 34: 0 to 1.25 V, 35: 0 to 5 V, 36: 0 to 10 V, 37: ±100 mV user-set range, 38: ±1.25 V, 39: ±5 V, 40: ±10 V, 41: ±10 V user-set range When the Resolution Switch Is Set to 2 (1/16,000) 15: K (1), 20: E |
| | | | | | | | Process Value Input Range |
| m+35 | m+50 | m+65 | m+80 | -32000 to 32000 | 8300 to FFFF hex 0000 to 7D00 hex | 10000 (2710 hex) | <p>Maximum Input Signal Value (Set value × 0.1°C for °C, set value × 0.1°F for °F, set value × 0.1 mV for ±100 mV user-set range, set value × 0.001 V for ±10 V user-set range, set value × 1 Ω for potentiometer)</p> <p>Note: Only for a temperature input user-set range for a DC input, or a potentiometer input.</p> |
| m+36 | m+51 | m+66 | m+81 | -32000 to 32000 | 8300 to FFFF hex 0000 to 7D00 hex | 0 (0000 hex) | <p>Minimum Input Signal Value (Set value × 0.1°C for °C, set value × 0.1°F for °F, set value × 0.1 mV for ±100 mV user-set range, set value × 0.001 V for ±10 V user-set range, set value × 1 Ω for potentiometer)</p> <p>Note: Only for a temperature input user-set range for a DC input, or a potentiometer input.</p> |
| m+37 | m+52 | m+67 | m+82 | 0, 1 | 0000, 0001 hex | 0 (0000 hex) | <p>Unit 0: °C, 1: °F</p> |
| | | | | | | | Process Value Clamp Direction for Input Burnout |
| m+38 | m+53 | m+68 | m+83 | 0, 1 | 0000, 0001 hex | 0 (0000 hex) | 0: Upper limit, 1: Lower limit |

| DM Area address | | | | Data range | | Default | Data contents | |
|---|-------------|-------------|-------------|---------------------------|--|----------------------|--|--|
| Input No. 1 | Input No. 2 | Input No. 3 | Input No. 4 | Decimal | Hexadecimal | | | |
| | | | | | | | Process Value Scaling | |
| m+39 | m+54 | m+69 | m+84 | -2147483648 to 2147483647 | 80000000 to FFFFFFFF hex, 00000000 to 7FFFFFFF hex | 10000 (00002710 hex) | Lower | Value Stored for Maximum Value in Range (Span) |
| m+40 | m+55 | m+70 | m+85 | | | | Upper | |
| m+41 | m+56 | m+71 | m+86 | -2147483648 to 2147483647 | 80000000 to FFFFFFFF hex, 00000000 to 7FFFFFFF hex | 0 (00000000 hex) | Lower | Value Stored for Minimum Value in Range (Zero) |
| m+42 | m+57 | m+72 | m+87 | | | | Upper | |
| m+43 | m+58 | m+73 | m+88 | -2147483648 to 2147483647 | 80000000 to FFFFFFFF hex, 00000000 to 7FFFFFFF hex | 0 (00000000 hex) | Lower | Scaling Offset |
| m+44 | m+59 | m+74 | m+89 | | | | Upper | |
| | | | | | | | Alarm Supplementary Functions | |
| m+45 | m+60 | m+75 | m+90 | 0 to 32767 | 0000 to 7FFF hex | 40 (0028 hex) | Alarm Hysteresis (Set to process value scaling value. Shared with process value alarm and rate-of-change alarm.) | |
| m+46 | m+61 | m+76 | m+91 | 0 to 60 | 0000 to 003C hex | 0 (0000 hex) | Alarm ON-delay Time (Unit: s) (Shared with process value alarm and rate-of-change alarm.) | |
| m+47 | m+62 | m+77 | m+92 | 0 to 60 | 0000 to 003C hex | 0 (0000 hex) | Alarm OFF-delay Time (Unit: s) (Shared with process value alarm and rate-of-change alarm.) | |
| | | | | | | | Mean Value Processing Function | |
| m+48 | m+63 | m+78 | m+93 | 0 to 128 | 0000 to 0080 hex | 0 (0000 hex) | Number of Process Values for Calculating Moving Average for Mean Value Processing 0: 4 values for a resolution of 1/256,000, 25 values for a resolution of 1/64,000 or 1/16,000 1 to 128: Number of process values | |
| Display parameter | | | | | | | | |
| m+94 | m+95 | m+96 | m+97 | 0 to 99, 100 to 1XX | 0000 to 0063 hex, 0064 to 0XXX hex | 0 (0000 hex) | Address of Data Range Error (See note 2.) | |
| Expansion Setting Area Allocation Settings | | | | | | | | |
| m+98 | | | | 0 to 5 | 0000 to 0005 hex | --- | Area of Expansion Setting Area 0: Not used; 1: DM; 2: CIO; 3: W; 4: H; 5: EM | |
| m+99 | | | | 0 to 32767 | 0000 to 7FFF hex | --- | First Word in Expansion Setting Area | |

Note 1. The operation settings are as follows:

| Address | Bits | Descriptions | Settings |
|---------|----------|---|---|
| m+1 | 00 to 03 | Resolution Switch | 0: 1/256,000 (conversion period: 60 ms) 1: 1/64,000 (conversion period: 10 ms) 2: 1/16,000 (conversion period: 5 ms) |
| | 04 to 07 | Process Value Data Length (Sets the data length for the process value, rate of change, peak value, top value, bottom value, and valley value.) | 0: 2 words (signed double word binary data) 1: 1 word (Restricted to the following range: -32768 to 32767 (8000 to FFFF hex, 0000 to 7FFF hex).) |

- The ERC indicator on the front of the Analog Input Unit will light if a setting in the Set Group 1 (continuously refreshed area), Setting Group 2 (initial settings area), or Expansion Setting Area Allocation Settings Area is out of range. The offset from word m to the first address containing the out-of-range error will be stored as the Address of Data Range Error in the DM Area in four digits hexadecimal. If the first memory address where the out-of-range error occurred is in the Expansion Setting Area, the Address of Data Range Area will be +100 or later. If the first word of the Expansion Setting Area has the error, the Address of Data Range Area will be +100.
- When specifying an Expansion Setting Area, be sure that it does not overlap with other areas that are being used. If areas overlap, the words that are allocated may be overwritten, resulting in unexpected operation.
- When specifying the first word in an Expansion Setting Area, be sure that the end of the memory area is not exceeded.
- Set the first word in an Expansion Setting Area to an even-numbered address.

Expansion Setting Area Allocations

First word: word o. o = address specified in word m+99 in the area specified by word m+98 in the DM Area.

| DM Area address | | | | Data range | | Default | Data contents | |
|--|-------------|-------------|-------------|---------------------------|--|-----------------------|--|--|
| Input No. 1 | Input No. 2 | Input No. 3 | Input No. 4 | Decimal | Hexadecimal | | | |
| Setting Group 3 (continuously refreshed area): Parameters that are continuously refreshed during PLC operation (can be set regardless of the CPU Unit's operation mode) | | | | | | | | |
| | | | | | | | Process Value Alarm Set Value | |
| o | o+8 | o+16 | o+24 | -2147483648 to 2147483647 | 80000000 to FFFFFFFF hex, 00000000 to 7FFFFFFF hex | 42000 (0000A410 hex) | Lower | Process Value HH (High High Limit) Alarm Setting (Set to process value scaling value.) |
| o+1 | o+9 | o+17 | o+25 | | | | Upper | |
| o+2 | o+10 | o+18 | o+26 | -2147483648 to 2147483647 | 80000000 to FFFFFFFF hex, 00000000 to 7FFFFFFF hex | -2000 (FFFFFF830 hex) | Lower | Process Value LL (Low Low Limit) Alarm Setting (Set to process value scaling value.) |
| o+3 | o+11 | o+19 | o+27 | | | | Upper | |
| | | | | | | | Rate-of-change Value Alarm Settings | |
| o+4 | o+12 | o+20 | o+28 | -2147483648 to 2147483647 | 80000000 to FFFFFFFF hex, 00000000 to 7FFFFFFF hex | 40000 (00009C40 hex) | Lower | Rate-of-change Value H (High Limit) Alarm Setting (Set to rate-of-change scaling value.) |
| o+5 | o+13 | o+21 | o+29 | | | | Upper | |

| DM Area address | | | | Data range | | Default | Data contents | |
|--|-------------|-------------|-------------|---------------------------|--|-----------------------|--|---|
| Input No. 1 | Input No. 2 | Input No. 3 | Input No. 4 | Decimal | Hexadecimal | | | |
| o+6 | o+14 | o+22 | o+30 | -2147483648 to 2147483647 | 80000000 to FFFFFFFF hex, 00000000 to 7FFFFFFF hex | 0 (00000000 hex) | Lower | Rate-of-change Value L (Low Limit) Alarm Setting (Set at rate-of-change scaling value.) |
| o+7 | o+15 | o+23 | o+31 | | | | Upper | |
| Setting Group 4 (initial settings area): Parameters that are transferred one time from the CPU Unit to the Analog Input Unit when an Expansion Setting Area is allocated if word m contains other than 12345 when the PLC is turned ON or the Analog Input Unit is restarted. | | | | | | | | |
| | | | | | | | Expansion Allocation Area Settings | |
| o+32 | | | | 0 to 5 | 0000 to 0005 hex | --- | Area for Expansion Allocation Area 0: Not used. , 1: DM, 2: CIO, 3: W, 4: H, 5: EM | |
| o+33 | | | | 0 to 32767 | 0000 to 7FFFF hex | --- | First Address in the Expansion Allocation Area | |
| Square Root Calculations | | | | | | | | |
| o+34 | o+48 | o+62 | o+76 | 0, 1 | 0000, 0001 hex | 0 (0000 hex) | Square Root Extraction (Valid when max. scaling value \geq minimum scaling value.) 0: Disable, 1: Enable | |
| Rate-of-change Function | | | | | | | | |
| Rate-of-change Range Settings | | | | | | | | |
| o+35 | o+49 | o+63 | o+77 | -32000 to 32000 | 8300 to FFFF hex, 0000 to 7D00 hex | 10000 (2710 hex) | Maximum Rate-of-change Value (Process value industrial unit/ comparison time interval) | |
| o+36 | o+50 | o+64 | o+78 | -32000 to 32000 | 8300 to FFFF hex, 0000 to 7D00 hex | -10000 (D810 hex) | Minimum Rate-of-change Value (Process value industrial unit/comparison time interval) | |
| o+37 | o+51 | o+65 | o+79 | 1 to 16 | 0001 to 0010 hex | 1 (0001 hex) | Rate-of-change Comparison Time Interval (See note 1.) Bits 00 to 07: Comparison time Bits 08 to 15: Unit | |
| Rate-of-change Value Scaling | | | | | | | | |
| o+38 | o+52 | o+66 | o+80 | -2147483648 to 2147483647 | 80000000 to FFFFFFFF hex, 00000000 to 7FFFFFFF hex | 10000 (00002710 hex) | Lower | Value Stored for Maximum Value in Range |
| o+39 | o+53 | o+67 | o+81 | | | | Upper | |
| o+40 | o+54 | o+68 | o+82 | -2147483648 to 2147483647 | 80000000 to FFFFFFFF hex, 00000000 to 7FFFFFFF hex | -10000 (FFFFD810 hex) | Lower | Value Stored for Minimum Value in Range |
| o+41 | o+55 | o+69 | o+83 | | | | Upper | |
| Zero/Span Adjustment Supplementary Function | | | | | | | | |
| o+42 | o+56 | o+70 | o+84 | 0 to 32000 | 0000 to 7D00 hex | 10000 (2710 hex) | Span Adjustment Position (Set value x 0.01%, percentage of input span) | |
| o+43 | o+57 | o+71 | o+85 | -32000 to 32000 | 8300 to FFFF hex, 0000 to 7D00 hex | 0 (0000 hex) | Zero Adjustment Position (Set value x 0.01%, percentage of input span) | |
| o+44 | o+58 | o+72 | o+86 | 0 to 9999 | 0000 to 270F hex | 365 (016D hex) | Zero/Span Adjustment Period (Unit: Days) | |
| o+45 | o+59 | o+73 | o+87 | 0 to 9999 | 0000 to 270F hex | 30 (001E hex) | Notice of Days Remaining (Unit: Days) | |
| Top and Valley Hold | | | | | | | | |
| o+46 | o+60 | o+74 | o+88 | 0 to 32767 | 0000 to 7FFF hex | 40 (0028 hex) | Hysteresis | |

| DM Area address | | | | Data range | | Default | Data contents | |
|-----------------|-------------|-------------|-------------|---------------------------|--|---------------------------|--|---|
| Input No. 1 | Input No. 2 | Input No. 3 | Input No. 4 | Decimal | Hexadecimal | | | |
| | | | | | | | Integral Value Calculation (See note 1.) | |
| o+47 | o+61 | o+75 | o+89 | (See note.) | (See note.) | 0 (0000 hex) | Bits 00 to 07: Integer Unit Bits 08 to 15: Integer Coefficient | |
| | | | | | | | Temperature Resistance Thermometer Compensation | |
| o+90 | | | | (See note.) | (See note.) | 0 (0000 hex) | Temperature Resistance Thermometer Compensation Enable (See note 1.) | |
| o+91 | o+93 | o+95 | o+97 | -2147483648 to 2147483647 | 80000000 to FFFFFFFF hex, 00000000 to 7FFFFFFF hex | 1089585403 (40F1C0FB hex) | Lower | Reference Resistance (resistance at 23°C) (Set value × 0.0000001(10 ⁻⁷) Ω for Pt100 or JPt100, or Set value × 0.000001(10 ⁻⁶) Ω for Pt1000) |
| o+92 | o+94 | o+96 | o+98 | | | | Upper | |
| | | | | | | | Cold Junction Compensation Method Settings | |
| o+99 | | | | (See note.) | (See note.) | 0 (0000 hex) | Cold Junction Compensation Method (See note 1.) | |

Note The settings for the Rate-of-change Comparison Time Interval, Integral Value Calculation, Temperature Resistance Thermometer Compensation, and Cold Junction Compensation Method are as follows:

| Address | Bits | Description | Settings | |
|------------------------------|----------|---|---|------------------|
| | | | Decimal | Hexadecimal |
| o+37 o+51 o+65 o+79 | 00 to 07 | Rate-of-change Comparison Time Interval | 1 to 16 | 0001 to 0010 hex |
| | 08 to 15 | Unit | 0: s 1: Conversion period | |
| o+47 o+61 o+75 o+89 | 00 to 07 | Integral Unit | 0: Minutes 1: Hours | |
| | 08 to 15 | Integer Coefficient | 0: 1 1: 1/10 2: 1/100 3: 1/1,000 4: 1/10,000 | |
| o+90 | 00 | Input No. 1 Temperature Resistance Thermometer Compensation | 0: Disabled 1: Enabled | |
| | 01 | Input No. 2 Temperature Resistance Thermometer Compensation | | |
| | 02 | Input No. 3 Temperature Resistance Thermometer Compensation | | |
| | 03 | Input No. 4 Temperature Resistance Thermometer Compensation | | |
| | 04 to 15 | Not used. | | |
| o+99 | 00 | Input No. 1 Cold Junction Compensation Method | 0: Internal (Use the Unit's cold junction sensor.) 1: External (Do not use the Unit's cold junction sensor.) | |
| | 01 | Input No. 2 Cold Junction Compensation Method | | |
| | 02 | Input No. 3 Cold Junction Compensation Method | | |
| | 03 | Input No. 4 Cold Junction Compensation Method | | |
| | 04 to 15 | Not used. | | |

- Note**
1. When specifying an Expansion Allocation Area, be sure that it does not overlap with other areas that are being used. If areas overlap, the words that are allocated may be overwritten, resulting in unexpected operation.
 2. When specifying the first word in an Expansion Allocation Area, be sure that the end of the memory area is not exceeded.
 3. Set the first word in an Expansion Allocation Area to an even-numbered address.

CIO Area Allocations

First word: word n. $n = 2000 + \text{unit number} \times 10$ (unit number: 0 to 95)

| Direction | Word | Bits | Name | | Data range | Contents | |
|-------------------------------|------|-------------|--|--|-----------------------------|---|---|
| Analog Input Unit to CPU Unit | n | 00 to 15 | Input No. 1 | Lower | Process Value (See note 1.) | -2147483648 to +2147483647 (80000000 to FFFFFFFF hex, 00000000 to 7FFFFFFF hex) | The present process value is stored according to the scaling set in the allocated words of the DM Area. |
| | n+1 | 00 to 15 | | Upper | | | |
| | n+2 | 00 to 15 | Input No. 2 | Lower | | | |
| | n+3 | 00 to 15 | | Upper | | | |
| | n+4 | 00 to 15 | Input No. 3 | Lower | | | |
| | n+5 | 00 to 15 | | Upper | | | |
| | n+6 | 00 to 15 | Input No. 4 | Lower | | | |
| | n+7 | 00 to 15 | | Upper | | | |
| | n+8 | 00 | Input No. 1 | Process Value LL (Low Low Limit) Alarm | | 0, 1 | 0: Process value > Set value |
| | | 01 | | Process Value L (Low Limit) Alarm | | 0, 1 | 1: Process value ≤ Set value (See note 2.) |
| | | 02 | | Process Value H (High Limit) Alarm | | 0, 1 | 0: Process value < Set value |
| | | 03 | | Process Value HH (High High Limit) Alarm | | 0, 1 | 1: Process value ≥ Set value (See note 2.) |
| | | 04 | Input No. 2 | Process Value LL (Low Low Limit) Alarm | | 0, 1 | Same as for input No. 1. (See note 2.) |
| | | 05 | | Process Value L (Low Limit) Alarm | | | |
| | | 06 | | Process Value H (High Limit) Alarm | | | |
| | | 07 | | Process Value HH (High High Limit) Alarm | | | |
| | | 08 | Input No. 3 | Process Value LL (Low Low Limit) Alarm | | | |
| | | 09 | | Process Value L (Low Limit) Alarm | | | |
| | | 10 | | Process Value H (High Limit) Alarm | | | |
| | | 11 | | Process Value HH (High High Limit) Alarm | | | |
| | 12 | Input No. 4 | Process Value LL (Low Low Limit) Alarm | | | | |
| | 13 | | Process Value L (Low Limit) Alarm | | | | |
| | 14 | | Process Value H (High Limit) Alarm | | | | |
| | 15 | | Process Value HH (High High Limit) Alarm | | | | |

| Direction | Word | Bits | Name | | Data range | Contents | |
|-------------------------------|------------------------------------|------|------------------------------------|---|------------|--|-----------------------|
| Analog Input Unit to CPU Unit | n+9 | 00 | Input No. 1 | Rate-of-change Value L (Low Limit) Alarm | 0, 1 | 0: Rate of change > Set value 1: Rate of change ≤ Set value (See note 3.) | |
| | | 01 | | Rate-of-change Value H (High Limit) Alarm | 0, 1 | 0: Rate of change < Set value 1: Rate of change ≥ Set value (See note 3.) | |
| | | 02 | Input No. 2 | Rate-of-change Value L (Low Limit) Alarm | 0, 1 | Same as for input No. 1. (See note 3.) | |
| | | 03 | | Rate-of-change Value H (High Limit) Alarm | 0, 1 | | |
| | | 04 | Input No. 3 | Rate-of-change Value L (Low Limit) Alarm | 0, 1 | | |
| | | 05 | | Rate-of-change Value H (High Limit) Alarm | 0, 1 | | |
| | | 06 | Input No. 4 | Rate-of-change Value L (Low Limit) Alarm | 0, 1 | | |
| | | 07 | | Rate-of-change Value H (High Limit) Alarm | 0, 1 | | |
| | | 08 | Input No. 1 | Input Error | 0, 1 | | 0: Normal 1: Error |
| | | 09 | Input No. 2 | | | | |
| | | 10 | Input No. 3 | | | | |
| | | 11 | Input No. 4 | | | | |
| | | 12 | Cold Junction Sensor Error | | 0, 1 | 0: Normal 1: Error | |
| | | 13 | Zero/Span Adjustment Period End | | 0, 1 | 0: Adjustment enabled. 1: Adjustment ended. (See note 3.) Remains set to 1 if the zero/span adjustment bit has never been ON. | |
| | | 14 | Zero/span Adjustment Period Notice | | 0, 1 | 0: Adjustment enabled. 1: Notice period in effect. (See note 3.) Remains set to 1 if the zero/span adjustment bit has never been ON. | |
| 15 | A/D Conversion Error (See note 4.) | | 0, 1 | 0: Normal 1: Error | | | |

- Note**
- To indicate the process value in one word of data, set scaling in the range of -32,768 to 32,767 (8000 to FFFF hex or 0000 to 7FFF hex), and set the process value data length to 1 (one word).
 - If an Expansion Allocation Area is not set, the Process Value HH (High High Limit) Alarm and Process Value LL (Low Low Limit) Alarm will be 0.
 - This value will be 0 if neither the Expansion Setting Area nor the Expansion Control/Monitor Area is used.
 - This value will be 1 if an error occurs in the A/D conversion. If the error is not cleared by turning the power OFF and back ON or restarting the Unit, check whether there is a source of noise nearby. For details, refer to *Error Processing* on page 363.

Expansion Allocation Area

First word: word p. p = address specified in word o+33 in the area specified by word o+32 in the Expansion Setting Area.

| Direction | Word | Bits | Name | | Data range | Contents | |
|-------------------------------|----------|-----------|-------------|---------------------------------|----------------------------------|--|---|
| CPU Unit to Analog Input Unit | p | 00 to 15 | Not used. | | 0000 | --- | |
| | p+1 | 00 | Input No. 1 | Hold Function Selection | 0, 1 | 0: Peak and bottom 1: Top and valley | |
| | | 01 | Input No. 2 | | | | |
| | | 02 | Input No. 3 | | | | |
| | | 03 | Input No. 4 | | | | |
| | | 04 to 07 | Not used. | | 0 | --- | |
| | | 08 | Input No. 1 | Hold Start | 0, 1 | 0: Do not hold. 1: Hold. | |
| | | 09 | Input No. 2 | | | | |
| | | 10 | Input No. 3 | | | | |
| | | 11 | Input No. 4 | | | | |
| | | 12 | Input No. 1 | Hold Value Reset | 0, 1 | 0: Normal operation 1: Reset hold value | |
| | | 13 | Input No. 2 | | | | |
| | | 14 | Input No. 3 | | | | |
| | | 15 | Input No. 4 | | | | |
| | | p+2 | 00 | Input No. 1 | Integral Value Calculation Start | 0, 1 | 0: Do not start calculation 1: Start calculation |
| | | | 01 | Input No. 2 | | | |
| | 02 | | Input No. 3 | | | | |
| | 03 | | Input No. 4 | | | | |
| | 04 | | Input No. 1 | Integral Value Reset | 0, 1 | 0: Normal operation 1: Reset integral value | |
| | 05 | | Input No. 2 | | | | |
| | 06 | | Input No. 3 | | | | |
| | 07 | | Input No. 4 | | | | |
| | 08 to 15 | Not used. | | 0 | --- | | |
| | p+3 | 00 | Input No. 1 | Zero/Span Adjustment Update Bit | 0, 1 | 0: Normal operation 1: Update adjustment date (Remains ON while writing external EEPROM.) | |
| | | 01 | Input No. 2 | | | | |
| | | 02 | Input No. 3 | | | | |
| | | 03 | Input No. 4 | | | | |
| 04 to 15 | | Not used. | | 0 | --- | | |

| Direction | Word | Bits | Name | | Data range | Contents | |
|-------------------------------|----------|------------------------------------|---|---|----------------------------|--|--|
| Analog Input Unit to CPU Unit | p+4 | 00 to 15 | Input No. 1 | Lower | Rate of Change (See note.) | -2147483648 to 2147483647 (80000000 to FFFFFFFF hex, 00000000 to 7FFFFFFF hex) | The present rate-of-change value is stored according to the scaling set in the Expansion Setting Area. |
| | p+5 | 00 to 15 | | Upper | | | |
| | p+6 | 00 to 15 | Input No. 2 | Lower | | | |
| | p+7 | 00 to 15 | | Upper | | | |
| | p+8 | 00 to 15 | Input No. 3 | Lower | | | |
| | p+9 | 00 to 15 | | Upper | | | |
| | p+10 | 00 to 15 | Input No. 4 | Lower | | | |
| | p+11 | 00 to 15 | | Upper | | | |
| | p+12 | 00 | Input No. 1 | Zero/Span Adjustment Period End | | 0, 1 | 0: Adjustment enabled. 1: Adjustment ended. Remains set to 1 if the Zero/Span Adjustment Bit has never been ON. |
| | | | | Zero/Span Adjustment Period Notice | | | |
| | | 02 | Input No. 2 | Zero/Span Adjustment Period End | | 0, 1 | Same as input No. 1. |
| | | | | Zero/Span Adjustment Period Notice | | | |
| | | | | 04 | Input No. 3 | | |
| | | Zero/Span Adjustment Period Notice | | | | 0, 1 | |
| | | 06 | Input No. 4 | Zero/Span Adjustment Period End | | | 0, 1 |
| | | | | Zero/Span Adjustment Period Notice | | 0, 1 | |
| | | 08 | EEPROM Error | | | | 0, 1 |
| | 09 to 15 | Not used. | | | | 0 | --- |
| | p+13 | 00 to 15 | Input No. 1 | Day of Final Adjustment Date | | 0100 to 3100(BCD) | Records the last date when the Zero/ Span Adjustment Update Bit was turned ON. Remains set to FFFF if the Zero/Span Adjustment Update Bit has never been ON. |
| | p+14 | 00 to 15 | | Year and Month of Final Adjustment Date | | 0001 to 9912(BCD) | |
| p+15 | 00 to 15 | Input No. 2 | Day of Final Adjustment Date | | 0100 to 3100(BCD) | | |
| p+16 | 00 to 15 | | Year and Month of Final Adjustment Date | | 0001 to 9912(BCD) | | |
| p+17 | 00 to 15 | Input No. 3 | Day of Final Adjustment Date | | 0100 to 3100(BCD) | | |
| p+18 | 00 to 15 | | Year and Month of Final Adjustment Date | | 0001 to 9912(BCD) | | |
| p+19 | 00 to 15 | Input No. 4 | Day of Final Adjustment Date | | 0100 to 3100(BCD) | | |
| p+20 | 00 to 15 | | Year and Month of Final Adjustment Date | | 0001 to 9912(BCD) | | |

| Direction | Word | Bits | Name | | Data range | Contents | | |
|-------------------------------|----------|-------------|-------------|---------------------------------|---------------------------------|--|--|----------------------|
| Analog Input Unit to CPU Unit | p+21 | 00 | Input No. 1 | Valley Detection Timing Flag | | 0, 1 | Turns ON when a valley is detected for the valley hold function. Turns OFF the next cycle. | |
| | | 01 | | Top Detection Timing Flag | | 0, 1 | | |
| | | 02 | Input No. 2 | Valley Detection Timing Flag | | 0, 1 | | Same as input No. 1. |
| | | 03 | | Top Detection Timing Flag | | 0, 1 | | |
| | | 04 | Input No. 3 | Valley Detection Timing Flag | | 0, 1 | | |
| | | 05 | | Top Detection Timing Flag | | 0, 1 | | |
| | | 06 | Input No. 4 | Valley Detection Timing Flag | | 0, 1 | | |
| | | 07 | | Top Detection Timing Flag | | 0, 1 | | |
| | 08 to 15 | Not used. | 0 | | --- | | | |
| | p+22 | 00 to 15 | Input No. 1 | Lower | Peak/Top Value (See note.) | -2147483648 to 2147483647 (80000000 to FFFFFFFF hex, 00000000 to 7FFFFFFF hex) | The peak or top value is stored according to the scaling set in the DM Area. | |
| | p+23 | 00 to 15 | | Upper | | | | |
| | p+24 | 00 to 15 | | Lower | Bottom/Valley Value (See note.) | | | |
| | p+25 | 00 to 15 | | Upper | | | | |
| | p+26 | 00 to 15 | Input No. 2 | Lower | Peak/Top Value (See note.) | -2147483648 to 2147483647 (80000000 to FFFFFFFF hex, 00000000 to 7FFFFFFF hex) | Same as for input No. 1. | |
| | p+27 | 00 to 15 | | Upper | | | | |
| p+28 | 00 to 15 | Lower | | Bottom/Valley Value (See note.) | | | | |
| p+29 | 00 to 15 | Upper | | | | | | |
| p+30 | 00 to 15 | Input No. 3 | Lower | Peak/Top Value (See note.) | | | | |
| p+31 | 00 to 15 | | Upper | | | | | |
| p+32 | 00 to 15 | | Lower | Bottom/Valley Value (See note.) | | | | |
| p+33 | 00 to 15 | | Upper | | | | | |
| p+34 | 00 to 15 | Input No. 4 | Lower | Peak/Top Value (See note.) | | | | |
| p+35 | 00 to 15 | | Upper | | | | | |
| p+36 | 00 to 15 | | Lower | Bottom/Valley Value (See note.) | | | | |
| p+37 | 00 to 15 | | Upper | | | | | |

| Direction | Word | Bits | Name | | Data range | Contents | |
|-------------------------------|------|----------|-------------|-------|----------------|---|---|
| Analog Input Unit to CPU Unit | p+38 | 00 to 15 | Input No. 1 | Lower | Integral Value | -2147483648 to +2147483647 (80000000 to FFFFFFFF hex, 00000000 to 7FFFFFFF hex) | The integral value for the present value is stored according to the scaling set in the DM Area. |
| | p+39 | 00 to 15 | | Upper | | | |
| | p+40 | 00 to 15 | Input No. 2 | Lower | Integral Value | | |
| | p+41 | 00 to 15 | | Upper | | | |
| | p+42 | 00 to 15 | Input No. 3 | Lower | Integral Value | | |
| | p+43 | 00 to 15 | | Upper | | | |
| | p+44 | 00 to 15 | Input No. 4 | Lower | Integral Value | | |
| | p+45 | 00 to 15 | | Upper | | | |

Note To indicate the value in one word of data, set scaling in the range of -32,768 to 32,767 (8000 to FFFF hex or 0000 to 7FFF hex), and set the process value data length to 1 (one word).

Terminal Connection Diagram

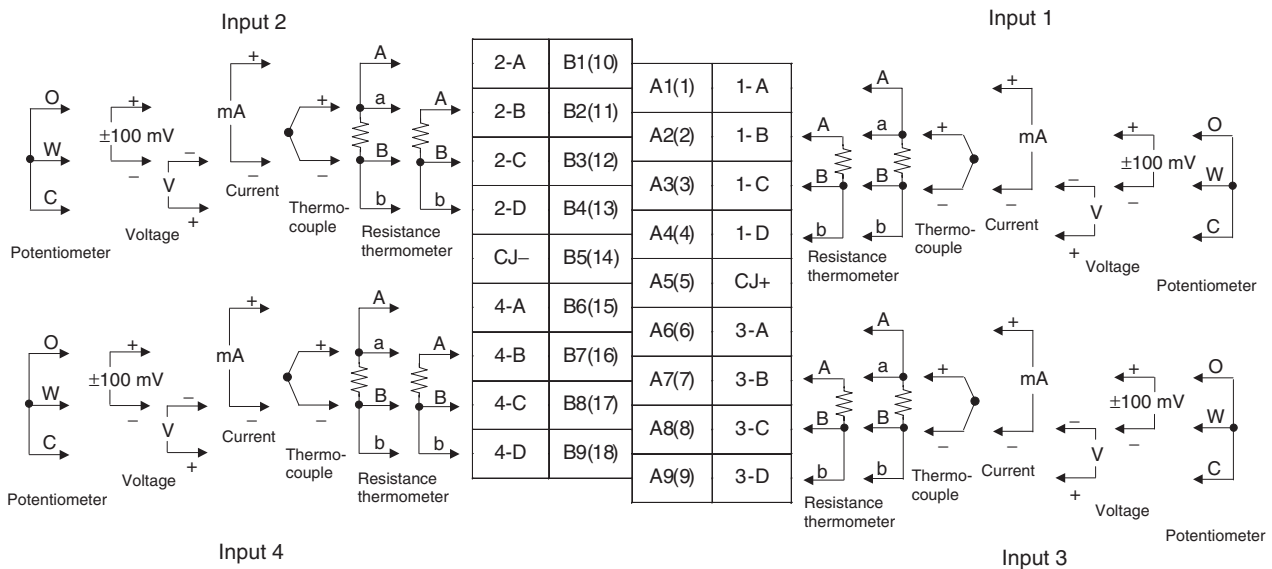

- Note**
1. When wiring voltage inputs, be careful not to connect the wrong terminals. Incorrect wiring may damage the Unit.
 2. Do not remove the cold junction sensors that are connected to the CJ+ and CJ- terminals. If they are removed, compensation will not be executed and temperatures will not be correctly measured.
 3. Use the cold junction sensors that are included with the product. Cold junction sensors are calibrated for particular Units and connection circuits. If a sensor from another Unit is used, temperatures cannot be correctly measured.
 4. Use shielded cable when the resolution selection is set to 2 (1/16,000).
 5. Use the same wiring length for connecting to A, B, a, and b, so that the impedance will be the same. In particular (for resistance thermometers), do not connect the A-a and B-b terminals.
 6. Do not connect anything to unused terminals.
 7. Be sure to ground the GR terminal at the Power Supply Unit for the PLC.
 8. Be sure to ground all input devices (such as voltage generators, temperature calibrators, and resistors) that have ground terminals.
 9. Do not mount an Isolated-type Universal Input Unit on the same CPU Rack or the same Expansion Rack as a CJ1W-OC□□□ Contact Output Unit. The Universal Input Unit measures process values at high resolution, and

the noise that is generated from relay output switching can adversely affect these operations.

10. If the CPU Rack and an Expansion Rack are lined up horizontally on the control panel and a Relay Output Unit is mounted in the same Rack as the CJ1W-PH41U, keep the Racks separated by at least 70 mm.
11. If for some reason it is not possible to avoid mounting them on the same Rack, then mount them as far apart as possible and take measures such as installing a surge suppressor in the relay output circuit wiring.

Shielded Cable

For 1/16,000 resolution, connect shielded cable as shown below.

■ **Thermocouple Input**

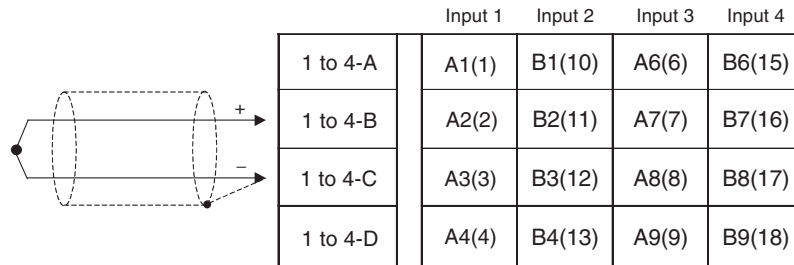

Block Diagram

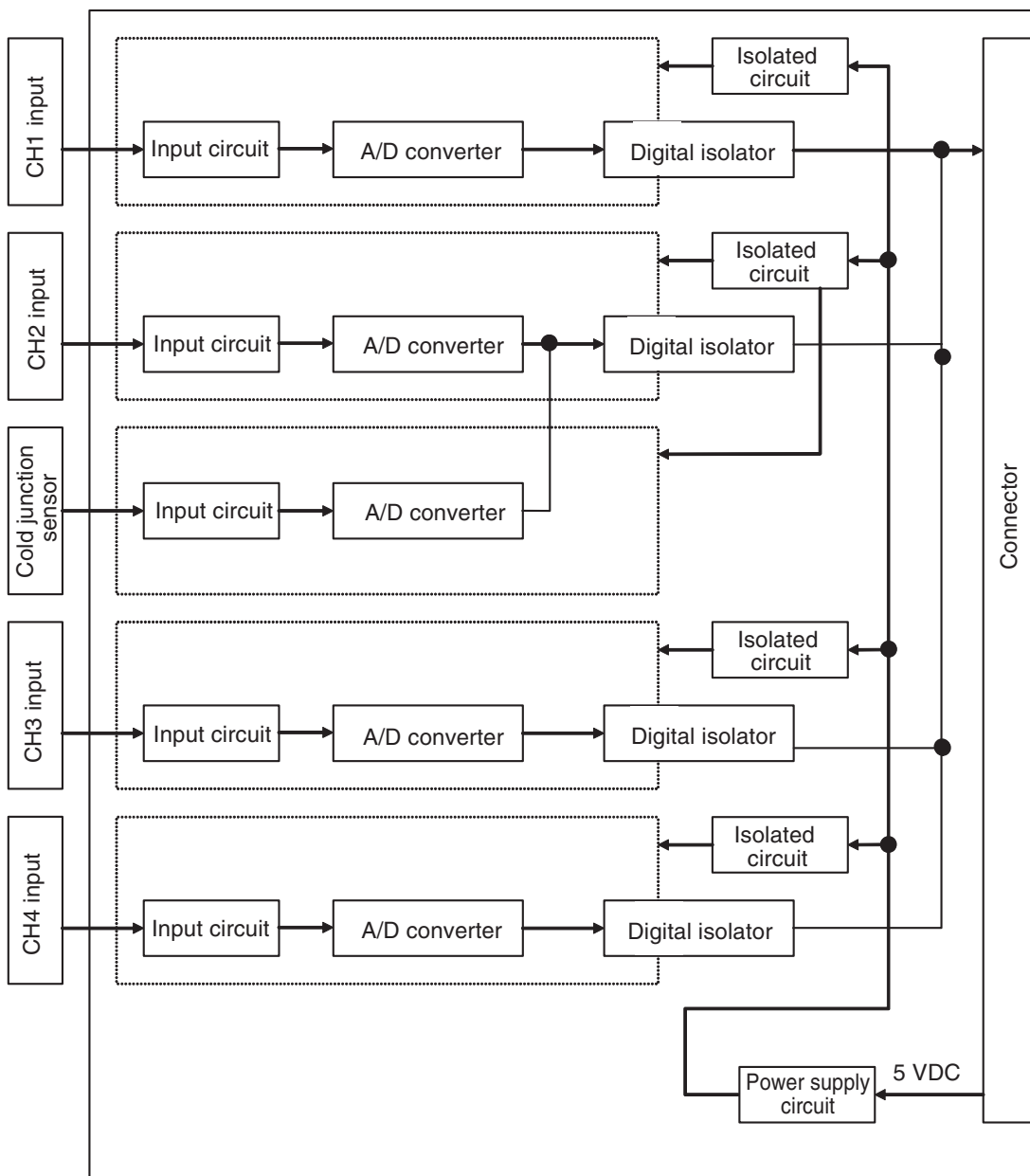

Error Processing**Conversion data does not change.**

| Probable cause | Remedy |
|--|---|
| The gain for span adjustment is set to 0. | Set the span adjustment gain to a value other than 0. |
| The maximum and minimum values set for process value scaling are identical or extremely close. | Set suitable maximum and minimum values for process value scaling. |
| The input type, input range, or process value scaling is not set correctly. | Check and correct the settings. |
| An input device is malfunctioning or input wiring is faulty or disconnected. | Check whether input values have changed. Check for faulty or disconnected wiring. Check whether an input error has been detected. |

Values are not converted as intended.

| Probable cause | Remedy |
|--|--|
| The input type, input range, or process value scaling is not set correctly. | Check and correct the settings. |
| The zero/span adjustment data is incorrect. | Check and correct the zero adjustment value and the span adjustment gain settings. |
| The resistance thermometer input wiring is incorrect. | Correct the input wiring. |
| Thermocouple or compensation conductor polarity is incorrect. | |
| DC input polarity is incorrect. | |
| Potentiometer input wiring is incorrect. | |
| Cold junction compensation is not operating. | Check the Cold Junction Error Flag. |
| A compensation conductor has not been used, or the wrong type of compensation conductor is used. | Use the correct compensation conductor for the thermocouple. |
| The offset compensation function is operating. | Set the scaling offset value to an appropriate value. |
| The square root calculation is operating. | Disable the square root calculation. |

Conversion values are unstable.

| Probable cause | Remedy |
|--|--|
| Input signals are being affected by external noise. | Change the connection paths of the input signal lines. (Separate them from sources of noise or use shielded twisted-pair cable.) |
| | Increase the number of items for moving average processing. |
| | Set the resolution to 1/256,000 (conversion period: 60 ms). |
| Process values greater than the resolution are being scaled. | Reduce the process value scaling value. |

An A/D conversion error occurred.

| Probable cause | Remedy |
|--|---|
| There is influence from ambient noise. | Install surge suppressors and noise filters for noise-generating devices. |
| | Separate the Unit from the noise source. |

The ERC indicator is lit.

| Probable cause | Remedy |
|---|---|
| A setting in the DM Area or the Expansion Setting Area is out of range. | Set the value within the optimum range. For Setting Group 2 or 4 (Initial Settings Area), turn the power OFF and back ON or restart the Unit. |
| | Set even addresses for the Expansion Setting Area and Expansion Control/Monitor Area beginning addresses. |

Appendix A

Supplementary Explanation of Functions

The following supplements the explanation given in *1-2 Features and Functions*.

Changing Set Values during Output of Process Value (or Instantaneous Value) Alarm or Rate-of-change Alarm

HH (High High Limit) and H (High Limit) Alarms

When the alarm set value is raised while the alarm output is ON, the alarm output will be turned OFF when the following condition is satisfied.

Input value < (alarm set value after change – hysteresis)

The alarm output will first turn OFF when the input value falls below the set value (with the hysteresis included).

LL (Low Low Limit) and L (Low Limit) Alarms

When the alarm set value is lowered while the alarm output is ON, the alarm output will be turned OFF when the following condition is satisfied.

Input value > (alarm set value after change + hysteresis)

When the hysteresis part alone of the input value is greater than the set value, the alarm output will turn OFF for the first time.

Example: HH and H Limit Alarms

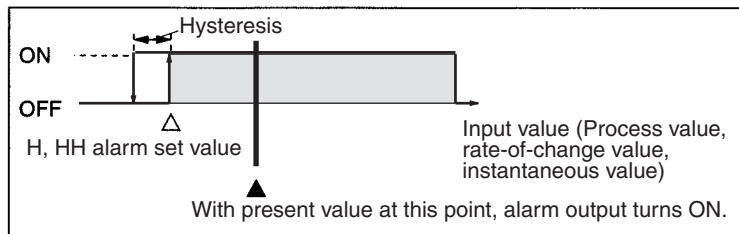

Alarm set value raised.

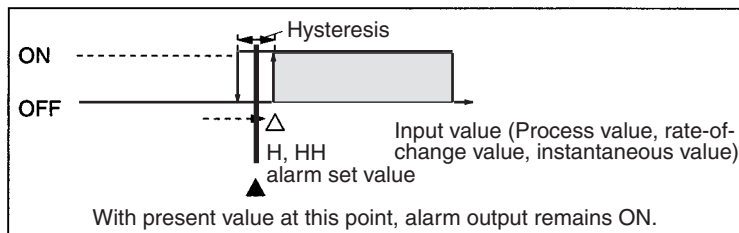

Alarm set value further raised.

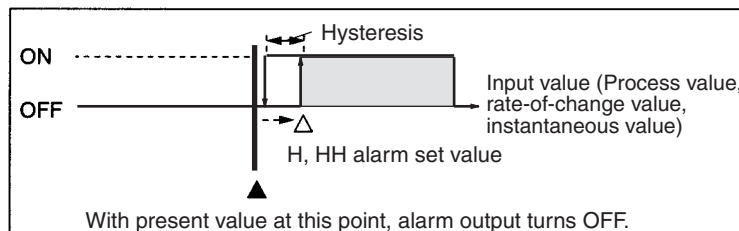

| | | |
|------------------|--|---------------------------------------|
| Applicable Units | Isolated-type Thermocouple Input Units | CS1W-PTS01-V1/11/51/55, CJ1W-PTS51/15 |
| | Isolated-type Resistance Thermometer Input Units | CS1W-PTS02/03/12/52/56, CJ1W-PTS52/16 |
| | Isolated-type 2-Wire Transmitter Input Unit | CS1W-PTW01 |
| | Isolated-type Direct Current Input Units | CS1W-PDC01/11/55, CJ1W-PDC15 |
| | Isolated-type Pulse Input Unit | CS1W-PPS01 |
| | Power Transducer Input Unit | CS1W-PTR01 |
| | Analog Input Unit (100 mV) | CS1W-PTR02 |
| | Isolated-type Universal Input Units | CS1W-PH41U |

Alarm Operation when Upper Limit Is Less Than Lower Limit

Process value (instantaneous value) and rate-of-change value alarm set values can be set freely regardless of the relative sizes of $HH > H > L > LL$.

Example: $H < L$, or $HH < H$.

The alarm output operation is determined purely by the relative sizes of the input value (screening value) and alarm set value, as shown below.

HH and H Limit Alarms

When the input value is greater than the alarm set value, the alarm output is turned ON.

LL and L Limit Alarms

When the input value is less than the alarm set value, the alarm output is turned ON.

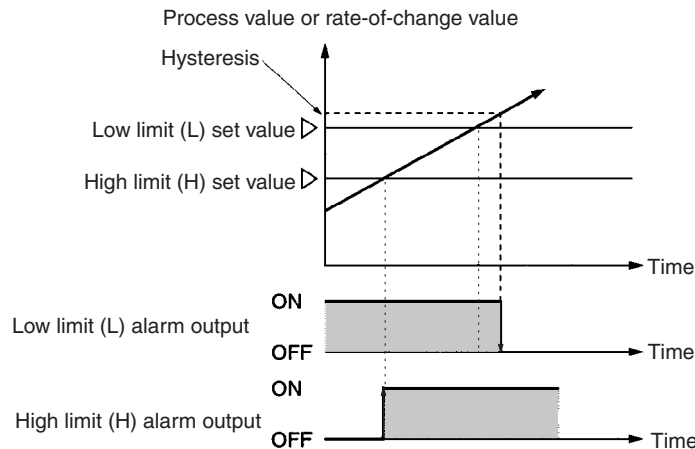

| | | |
|------------------|--|---------------------------------------|
| Applicable Units | Isolated-type Thermocouple Input Units | CS1W-PTS01-V1/11/51/55, CJ1W-PTS51/15 |
| | Isolated-type Resistance Thermometer Input Units | CS1W-PTS02/03/12/52/56, CJ1W-PTS52/16 |
| | Isolated-type 2-Wire Transmitter Input Unit | CS1W-PTW01 |
| | Isolated-type Direct Current Input Units | CS1W-PDC01/11/55, CJ1W-PDC15 |
| | Isolated-type Pulse Input Unit | CS1W-PPS01 |
| | Power Transducer Input Unit | CS1W-PTR01 |
| | Analog Input Unit (100 mV) | CS1W-PTR02 |
| | Isolated-type Universal Input Units | CJ1W-PH41U |

Note Rate-of-change value alarm is not available for CS1W-PTS5□/PDC55, and CJ1W-PTS51/PTS52. Process value alarm only.

Alarm Output Operation when Falling Back from Alarm Condition Before Alarm-ON Delay Time Elapses

If inputs fall back from the alarm-ON condition (including hysteresis) before the alarm-ON delay time has elapsed, the alarm output will not turn ON.

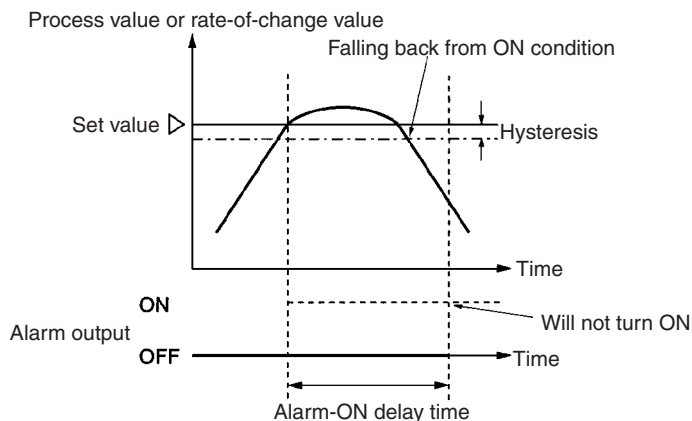

| | | |
|------------------|--|---------------------------------------|
| Applicable Units | Isolated-type Thermocouple Input Units | CS1WPTS01-V1/11/51/55, CJ1W-PTS51/15 |
| | Isolated-type Resistance Thermometer Input Units | CS1W-PTS02/03/12/52/56, CJ1W-PTS52/16 |
| | Isolated-type 2-Wire Transmitter Input Unit | CS1W-PTW01 |
| | Isolated-type Direct Current Input Units | CS1W-PDC01/11/55, CJ1W-PDC15 |
| | Isolated-type Pulse Input Unit | CS1W-PPS01 |
| | Power Transducer Input Unit | CS1W-PTR01 |
| | Analog Input Unit (100 mV) | CS1W-PTR02 |
| | Isolated-type Universal Input Units | CJ1W-PH41U (See note.) |

Note The alarm will not be turned OFF even if the alarm OFF condition is no longer met before the alarm OFF-delay time expires.

Setting Process Value Scaling with Negative Bias

With process value scaling in industrial units, a negative bias can be set by reversing the maximum and minimum values in the range.

Example: CS1W-PDC01 Isolated-type Direct Current Input Unit

The following values can be set for an input signal of 4 to 20 mA: Maximum process value in range = 0, minimum process value in range = 4000.

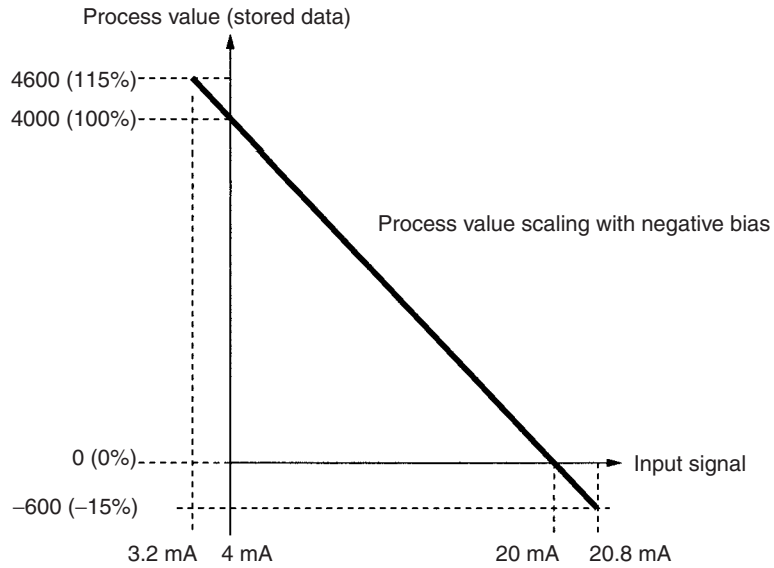

| | | |
|------------------|---|------------------------------|
| Applicable Units | Isolated-type Thermocouple Input Unit | CS1W-PTS01-V1/11, CJ1W-PTS15 |
| | Isolated-type Resistance Thermometer Input Unit | CS1W-PTS02/03/12, CJ1W-PTS16 |
| | Isolated-type 2-Wire Transmitter Input Unit | CS1W-PTW01 |
| | Isolated-type Direct Current Input Unit | CS1W-PDC01/11/55, CJ1W-PDC15 |
| | Isolated-type Pulse Input Unit | CS1W-PPS01 |
| | Power Transducer Input Unit | CS1W-PTR01 |
| | Analog Input Unit (100 mV) | CS1W-PTR02 |
| | Isolated-type Universal Input Units | CJ1W-PH41U |

Alarm Operation during Process Value Scaling with Negative Bias

During process value scaling with negative bias, the alarm operates on the process value after scaling, and not on the input signal. Consequently, the operation is the same as for normal bias, as shown below.

HH and H Limit Alarms

When the input value is greater than the alarm set value, the alarm output is turned ON.

LL and L Limit Alarms

When the input value is less than the alarm set value, the alarm output is turned ON.

Example: If the maximum process value in the range is 0 and minimum process value in the range is 4,000 for an input signal of 4 to 20 mA, and if the H (high limit) alarm set value is 3,000, the alarm output will turn ON when the process value is greater than 3,000 (when the input signal is less than 8 mA).

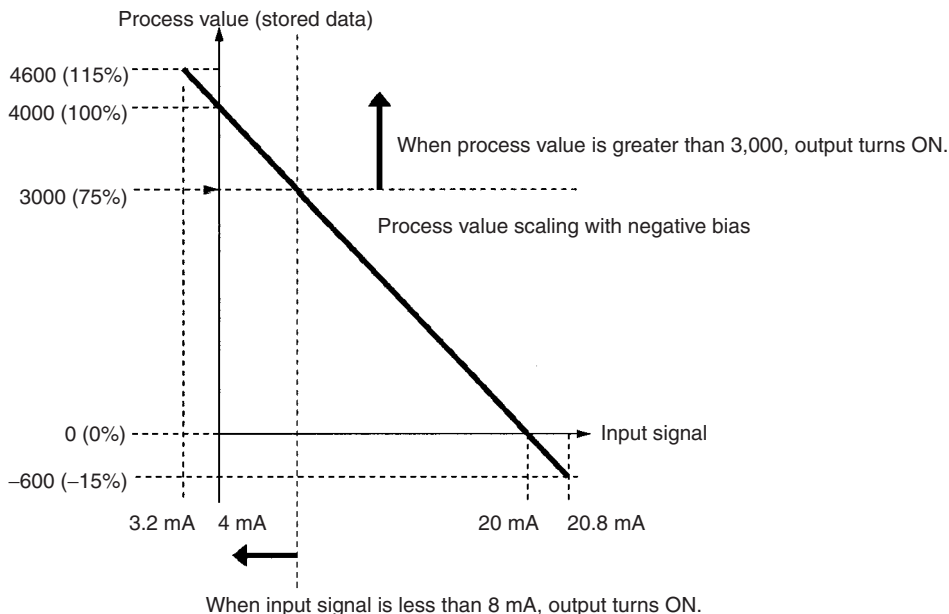

| | | |
|------------------|---|------------------------------|
| Applicable Units | Isolated-type Thermocouple Input Unit | CS1W-PTS01-V1/11, CJ1W-PTS15 |
| | Isolated-type Resistance Thermometer Input Unit | CS1W-PTS02/03/12, CJ1W-PTS16 |
| | Isolated-type 2-Wire Transmitter Input Unit | CS1W-PTW01 |
| | Isolated-type Direct Current Input Unit | CS1W-PDC01/11/55, CJ1W-PDC15 |
| | Isolated-type Pulse Input Unit | CS1W-PPS01 |
| | Power Transducer Input Unit | CS1W-PTR01 |
| | Analog Input Unit (100 mV) | CS1W-PTR02 |
| | Isolated-type Universal Input Units | CJ1W-PH41U |

Maximum/Minimum Value for when Input Disconnection Occurs during Process Value Scaling with Negative Bias

If an input is disconnected during process value scaling with negative bias, either the maximum or minimum process value will be specified.

If the process value overrange direction is high, the maximum process value will be specified.

If the process value overrange direction is low, the minimum process value will be specified.

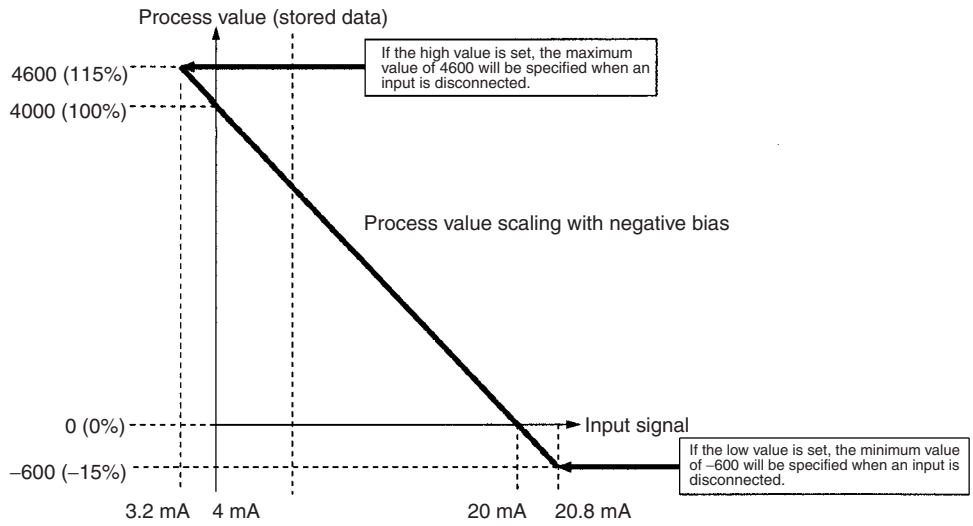

| | | |
|------------------|---|------------------------------|
| Applicable Units | Isolated-type Thermocouple Input Unit | CS1W-PTS01-V1/11, CJ1W-PTS15 |
| | Isolated-type Resistance Thermometer Input Unit | CS1W-PTS02/03/12, CJ1W-PTS16 |
| | Isolated-type Universal Input Units | CJ1W-PH41U |

Output Hold when CPU Unit Error Occurs

In the following cases, the CS1W-PMV01/PMV02 Isolated-type Analog Output Unit will hold either a specified preset value or the analog output value prior to the error for output when the CPU Unit is restored to normal operation.

- A fatal error (including user-defined FALS execution) occurs
- A CPU error occurs
- A load break occurs

When the CPU Unit is restored to normal operation, the output value in the CIO Area will be output.

Note If a CPU error occurs while the output rate-of-change limit function is operating, the output hold function will operate as follows:

- If previous value hold has been specified, then the value prior to the CPU error will be held for output.

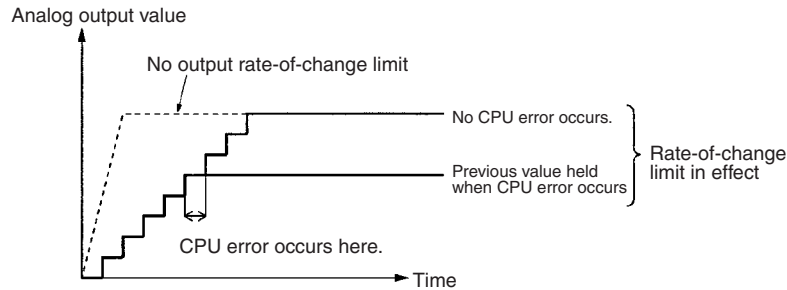

- When preset value hold has been specified, the output rate-of-change limit will remain in effect even during the change to the preset value, and the rate of change will be limited.

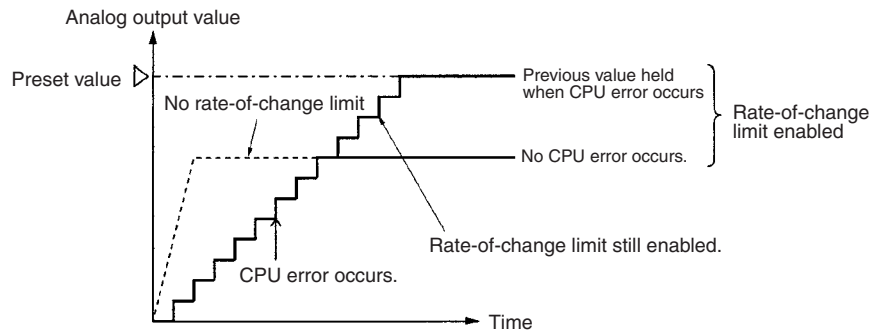

| | | |
|------------------|-----------------------------------|------------------|
| Applicable Units | Isolated-type Analog Output Units | CS1W-PMV01/PMV02 |
|------------------|-----------------------------------|------------------|

Inrush Input Limit Function

The inrush input limit function will not operate if the process value is already greater than 2% when the power supply to the PLC is turned ON. The inrush input limit function will operate only when the process value rises above 2% from less than 2% at startup.

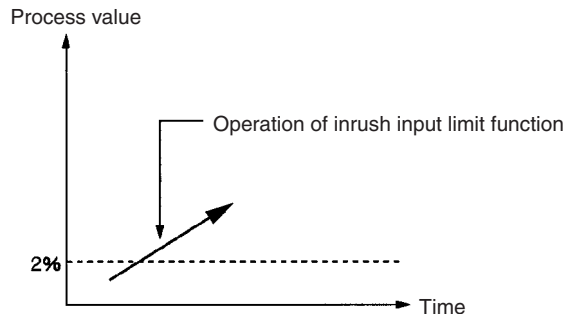

| | | |
|------------------|-----------------------------|------------|
| Applicable Units | Analog Input Unit (100 mV) | CS1W-PTR02 |
| | Power Transducer Input Unit | CS1W-PTR01 |

Hysteresis during Square Root Calculations

During square root calculations, outputs of approximately 7% or less have linear characteristics (i.e., output = input). Hysteresis exists, however, when switching between square root characteristics and linear characteristics, as shown below.

During input rise: Switching from linear characteristics to square root characteristics at 0.5% input (output of approximately 7%).

During input fall: Switching from square root characteristics to linear characteristics at 0.3% input (output of approximately 5.5%).

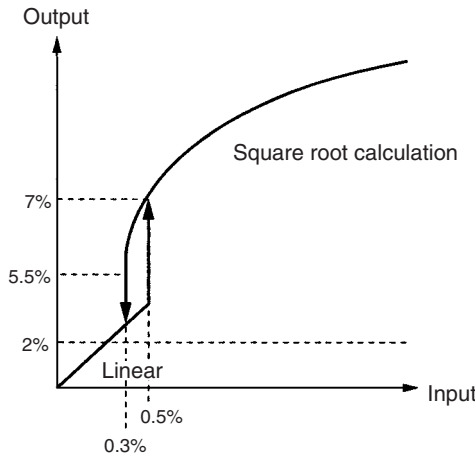

| | | |
|------------------|---|------------------------------|
| Applicable Units | Isolated-type 2-Wire Transmitter Input Unit | CS1W-PTW01 |
| | Isolated-type Direct Current Input Unit | CS1W-PDC01/11/55, CJ1W-PDC15 |
| | Isolated-type Universal Input Units | CS1W-PH41U |

Adjustment Period Control

Final Adjustment Date Not Stored in the Unit's External FROM (Initial Status)

The set values are as follows:

- The 4-byte area (2 words) for the final adjustment date is set to FFFF.
- The Zero/span Adjustment Period Notice Bit is set to 1 (notice period).
- The Zero/span Adjustment Period End Bit is set to 1 (adjustment ended).

Error in Final Adjustment Date Stored in Unit's External FROM when Power is Turned ON

The ERC indicator is ON and the adjustment period control function does not operate properly. Restart the Unit. The set values are as follows.

- The External FROM Error Flag is set to 1 (external FROM error).
- The 4-byte area (2 words) for the final adjustment date is set to FFFF.
- The Zero/span Adjustment Period Notice Bit is set to 1 (notice period).
- The Zero/span Adjustment Period End Bit is set to 1 (adjustment ended).

Error in Unit's External FROM when Updating Final Adjustment Date

The ERC indicator is ON and the adjustment period control function does not operate properly when the Unit is restarted. Update the final adjustment date again.

The set values are as follows.

- The External FROM Error Flag is set to 1 (external FROM error).

Note If the CPU Unit's internal clock information is refreshed after updating the final adjustment date, the warning will not be accurate. The Zero/span Adjustment Update Bit remains ON (1: Update adjustment date) while writing external FROM, so do not turn OFF the PLC.

| | | |
|------------------|---|------------------------|
| Applicable Units | Isolated-type Thermocouple Input Unit | CS1W-PTS11, CJ1W-PTS15 |
| | Isolated-type Resistance Thermometer Input Unit | CS1W-PTS12, CJ1W-PTS16 |
| | Isolated-type Direct Current Input Unit | CS1W-PDC11, CJ1W-PDC15 |
| | Isolated-type Universal Input Units | CJ1W-PH41U (See note.) |

Note For the CJ1W-PH41U, the "external FROM" is an external EEPROM.

Integral Value Calculation

Integral Value Unit: Hour

The process value is calculated using an integral width of 3.6 s (1/1,000th of an hour), and the total is output to 4 bytes (2 words) of memory.

An integral value of 1,000 indicates that a process value of 1,000 has continued for one hour.

Integral Value Unit: Minute

The process value is calculated using an integral width of 60 ms (1/1,000th of a minute), and the total is output to 4 bytes (2 words) of memory.

An integral value of 1,000 indicates that a process value of 1,000 has continued for one minute.

Example:

Process value: 1,000 (constant)

Integral unit: hour

| Time lapsed (hours) | Integral value |
|---------------------|----------------|
| 0.5 | 500 |
| 1 | 1,000 |
| 2 | 2,000 |
| 3 | 3,000 |

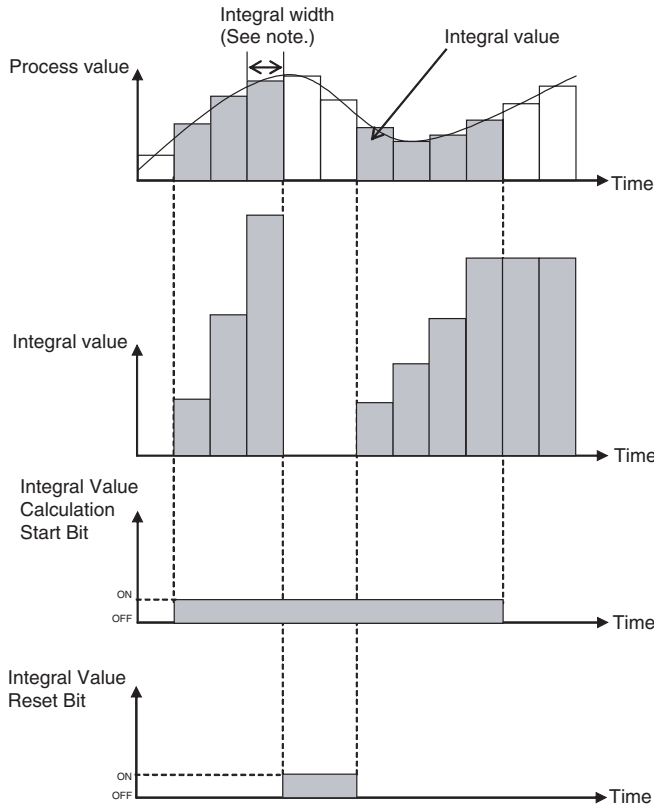

Note The integral width for one integral value is as follows:

| Unit | Integral width |
|--------|-------------------------------|
| Hour | 3.6 s (1/1,000th of an hour) |
| Minute | 60 ms (1/1,000th of a minute) |

Integral Value Overflow

The integral value will become undefined if the integral value exceeds the data range (−2147483648 to 2147483647) during integral calculation. For the CJ1W-PDC15, an integral value overflow will occur after a minimum of 45 days has lapsed from the start of integral calculation.

Example: Integral value overflow (minimum conditions). The table shows the integral values for the following minimum conditions.

- Process value: −32768 (constant)
- Integral unit: Minute

| Number of days lapsed (days) | Integral value |
|------------------------------|----------------|
| 0 | 0 |
| 1 | −47185920 |
| 2 | −94371840 |
| to | to |
| 45 | −2123366400 |
| 46 | Undefined |

Note Use the Integral Value Calculation Start Bit, the Integral Value Reset Bits, and (for the CJ1W-PH41U only) the integral coefficient so that an integral value overflow does not occur.

| | | |
|------------------|---|------------------------|
| Applicable Units | Isolated-type Direct Current Input Unit | CS1W-PDC11, CJ1W-PDC15 |
| | Isolated-type Universal Input Units | CJ1W-PH41U |

Appendix B

Zero/Span Adjustment Example

The Analog I/O Unit's zero/span adjustment can be performed as described below using a calibration device.

- 1,2,3...**
1. Connect the Programming Device to the CPU Unit.
 2. Connect a suitable calibration device as shown in the following table to the Analog I/O Unit.

| Name | Model | Calibration device |
|--|---------------|-------------------------------|
| Isolated-type Thermocouple Input Unit | CS1W-PTS01-V1 | Voltage and current generator |
| | CS1W-PTS11 | |
| | CS1W-PTS51 | |
| | CS1W-PTS55 | |
| | CJ1W-PTS51 | |
| | CJ1W-PTS15 | |
| Isolated-type Universal Input Unit (thermocouple inputs) | CJ1W-PH41U | |
| Isolated-type Resistance Thermocouple Input Unit (Pt100, JPt100) | CS1W-PTS02 | Variable resistor |
| Isolated-type Resistance Thermocouple Input Unit (Ni508.4) | CS1W-PTS03 | |
| Isolated-type Resistance Thermocouple Input Unit (Pt100, JPt100, JPt50, Ni508.4) | CS1W-PTS12 | |
| | CJ1W-PTS16 | |
| Isolated-type Resistance Thermocouple Input Unit (Pt100, JPt100) | CS1W-PTS52 | |
| | CS1W-PTS56 | |
| Isolated-type Resistance Thermocouple Input Unit (Pt100, JPt100) | CJ1W-PTS52 | |
| Isolated-type Universal Input Unit (Pt100, JPt100, Pt1000) | CJ1W-PH41U | |
| Isolated-type 2-Wire Transmitter Input Unit | CS1W-PTW01 | Voltage and current generator |
| Isolated-type Direct Current Input Unit | CS1W-PDC01 | Voltage and current generator |
| | CS1W-PDC11 | |
| | CS1W-PDC55 | |
| | CJ1W-PDC15 | |
| Isolated-type Universal Input Units (direct current inputs) | CJ1W-PH41U | |
| Analog Input Unit (100 mV) | CS1W-PTR02 | Voltage generator |
| Power Transducer Input Unit | CS1W-PTR01 | Voltage generator |
| Isolated-type Pulse Input Unit | CS1W-PPS01 | Pulse generator |
| Isolated-type Analog Output Unit | CS1W-PMV01 | Voltage and current meter |
| | CS1W-PMV02 | Voltage meter |

3. Turn ON the power to the PLC, and wait approximately 10 minutes for the Unit to warm up.
 The CS1W-PTS5□ and CJ1W-PTS5□ require approximately 30 minutes to warm up.
 The CS1W-PTS01-V1, CS1W-PTS11, and CJ1W-PTS15/PH41U require approximately 45 minutes to warm up.
4. Make the adjustments.

Input Units

- 1,2,3...**
1. Input a signal equivalent to 0% from the calibration device, and check the process value in the CPU Unit's CIO Area using the Programming Device. If the value is abnormal, change the zero adjustment value in the DM Area, and adjust the offset (parallel movement) value.
 2. Input a signal equivalent to 100% from the calibration device, and check the process value in the CPU Unit's CIO Area using the Programming Device. If the value is abnormal, change the span adjustment gain value in the DM Area, and adjust the gain (bias).

Note For the CJ1W-PTS15 Isolated-type Thermocouple Input Unit or CJ1W-PH41U Universal Input Unit, connect the terminals of the cold junction sensor. For the CJ1W-PTS15 Isolated-type Thermocouple Input Unit, connect the terminals for the cold junction sensor on the top. This will make the Isolated-type Thermocouple Input Unit or Universal Input Unit discontinue cold junction compensation. Then input a standard thermocouple value of 0°C (standard thermal power generation value, IEC 60584-1) to the calibration mV signal.

Output Units

- 1,2,3...**
1. Set an analog output value equivalent to 0% in the CPU Unit's CIO Area. Check the signal using the calibration device. If the value is abnormal, change the zero adjustment value in the DM Area, and adjust the offset (parallel movement) value.
 2. Set an analog output value equivalent to 100% in the CPU Unit's CIO Area. Check the signal using the calibration device. If the value is abnormal, change the span adjustment gain value in the DM Area, and adjust the gain (bias).

Adjust the zero/span according to the following equation.

Process value after adjustment = (input value – minimum process value in range) x DM Area span adjustment gain value + minimum process value in range + DM Area zero adjustment value

Example: Minimum process value in range = 0; maximum process value in range = 4,000; span adjustment gain = $10060 \times 0.0001 = 1.0060$; zero adjustment value = 5

If the input value is 500, the process value after adjustment will be as follows:

Process value after adjustment = $(500 - 0) \times 1.0060 + 0 + 5 = 508$.

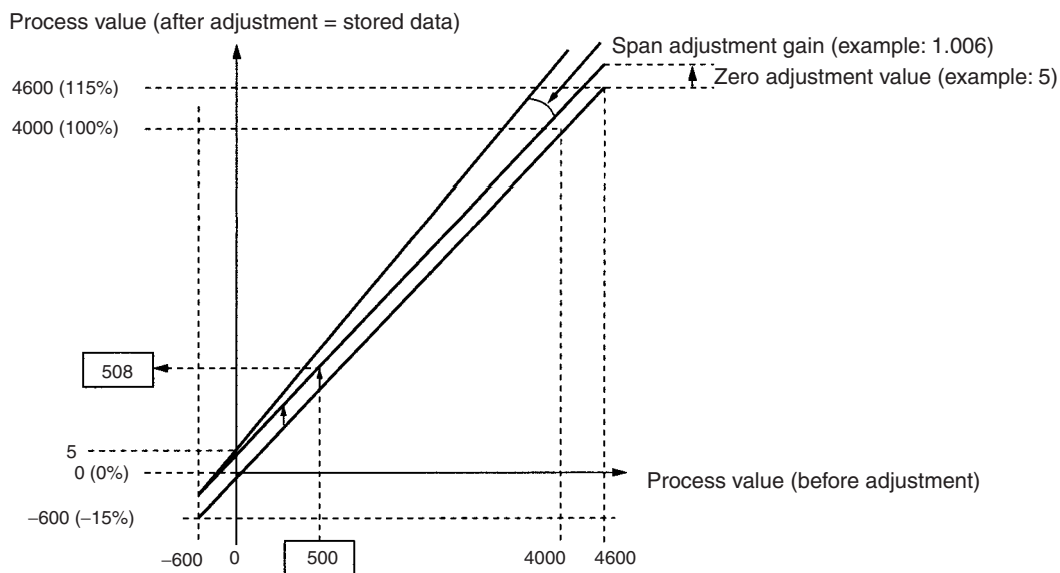

Zero/span Adjustment Example for Any Points (CS1W-PTS11/12, PDC11, CJ1W-PTS15/16, PDC15, PH41U)

Use the following adjustment equation to perform zero/span adjustment for any points.

$$\text{Process value after adjustment} = (X - B) \times ((C - A) \times E - B + A) / (C - B) + D + B$$

X: Input value

A: Zero point of allocated DM Area

B: Zero adjustment position (process value range)

C: Span adjustment position (process value range)

D: Zero adjustment value for allocated DM Area

E: Span adjustment gain for allocated DM Area

Note The zero adjustment position and span adjustment position are percentages of the input span in the Expansion Setting Area settings, so they can be obtained using the following equations.

Zero adjustment position = (Span point set in the allocated DM Area – Zero point set in the allocated DM Area) × Zero adjustment position set in the Expansion Setting Area + Zero point set in the allocated DM Area

Span adjustment position = (Span point set in the allocated DM Area – Zero point set in the allocated DM Area) × Span adjustment position set in the Expansion Setting Area + Zero point set in the allocated DM Area

Example: The values are calculated for the conditions in the following table.

| Item | Value |
|--|--|
| Zero point set in the Allocated DM Area | 0 |
| Span point set in the Allocated DM Area | 4000 |
| Span adjustment gain set in the Allocated DM Area | 10060 (10060 × 0.0001 = 1.0060) (See note.) |
| Zero adjustment position set in the Allocated DM Area | 5 |
| Zero adjustment position set in the Expansion Setting Area | 500 (500 × 0.0001 = 5%) |
| Span adjustment position set in the Expansion Setting Area | 9500 (9500 × 0.0001 = 95%) |
| Input value | 500 |

Note For the CJ1W-PH41U, the span adjustment gain setting is 10060000 (10060000 × 0.0000001 = 1.0060000).

After adjustment, the process value is as follows:

$$\text{Zero adjustment position} = (4000 - 0) \times 0.0500 + 0 = 200$$

$$\text{Span adjustment position} = (4000 - 0) \times 0.9500 + 0 = 3800$$

$$\text{Process value after adjustment} = (500 - 200) \times ((3800 - 0) \times 1.0060 - 200 + 0) / (3800 - 200) + 5 + 200 = 506.9$$

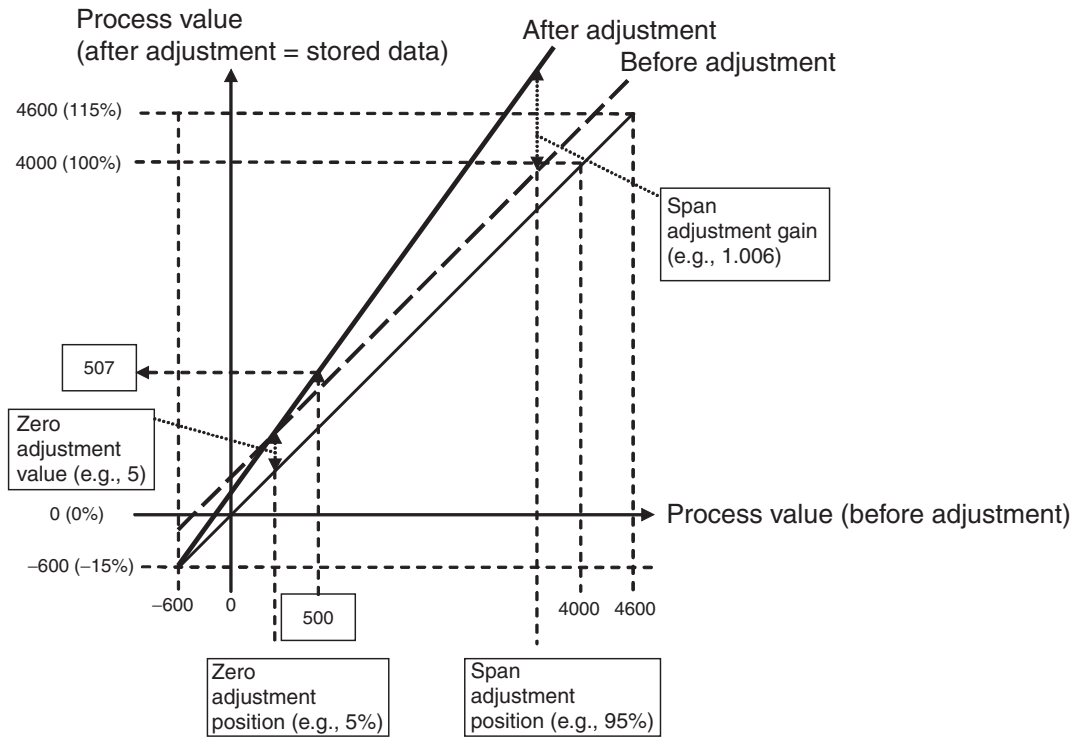

Index

A

- alarm
 - alarm-ON delay, 12, 13, 367
 - HH and H limits, 9, 365
 - hysteresis, 11, 372
 - LL and L limits, 9, 365
 - process value alarm, 9, 365
 - rate-of-change alarm, 10, 365
- allocation, 34
- answer input, 18
- applications
 - precautions, xx
- available models, 2
- average
 - mean value processing, 13

C

- CJ1W-PDC15
 - detailed description, 324
- CJ1W-PH41U
 - detailed description, 338
- CJ1W-PTS15
 - detailed description, 288
- CJ1W-PTS16
 - detailed description, 312
- CJ1W-PTS51
 - detailed description, 276, 338
- CJ1W-PTS52
 - detailed description, 302
- cold junction sensor
 - errors, 15
- CS1W-PDC01
 - detailed description, 189
- CS1W-PDC11
 - detailed description, 200
- CS1W-PDC55
 - detailed description, 218
- CS1W-PMV01
 - detailed description, 258
- CS1W-PMV02
 - detailed description, 267
- CS1W-PPS01
 - detailed description, 247
- CS1W-PTR01
 - detailed description, 229
- CS1W-PTR02

- detailed description, 238
- CS1W-PTS01-V1
 - detailed description, 68
- CS1W-PTS02
 - detailed description, 121
- CS1W-PTS03
 - detailed description, 132
- CS1W-PTS11
 - detailed description, 80
- CS1W-PTS12
 - detailed description, 142
- CS1W-PTS51
 - detailed description, 97
- CS1W-PTS52
 - detailed description, 157
- CS1W-PTS55
 - detailed description, 109
- CS1W-PTS56
 - detailed description, 167
- CS1W-PTW01
 - detailed description, 177

D

- default settings
 - transferring, 36, 39, 43
- delay
 - alarm-ON delay, 12, 13, 367
- detection
 - input disconnection detection, 14, 370
 - input error detection, 14
 - output disconnection detection, 19
- dimensions, 52
- disconnection
 - input disconnection detection, 14, 370
 - output disconnection detection, 19

E

- ERH indicator, 59
- error
 - cold junction sensor error, 15
 - error processing, 57
 - input error detection, 14
- error processing, 57

F

features

- CJ1W-PDC15, 324
- CJ1W-PH41U, 338
- CJ1W-PTS15, 288
- CJ1W-PTS16, 312
- CJ1W-PTS51, 276, 338
- CJ1W-PTS52, 302
- CS1W-PDC01, 189
- CS1W-PDC11, 200
- CS1W-PDC55, 218
- CS1W-PMV01, 258
- CS1W-PMV02, 267
- CS1W-PPS01, 247
- CS1W-PTR01, 229
- CS1W-PTR02, 238
- CS1W-PTS01-V1, 68
- CS1W-PTS02, 121
- CS1W-PTS03, 132
- CS1W-PTS11, 80
- CS1W-PTS12, 142
- CS1W-PTS51, 97
- CS1W-PTS52, 157
- CS1W-PTS55, 109
- CS1W-PTS56, 167
- CS1W-PTW01, 177

H

hysteresis, 11, 372

I

I/O Isolation, 7

input disconnection detection, 14, 370

input error detection, 14

input range

- variable input range setting, 7

inrush input limit, 16, 371

installation, 26

- precautions, xx

isolation

- I/O isolation, 7

L

LED Indicators, 30, 32

M

mean value processing, 13

models

- available models, 2

mounting Units, 48

N

nomenclature, 28

O

operating environment

- precautions, xix

operating procedures, 55

output disconnection detection, 19

output hold, 19, 371

output rate-of-change limit, 18

P

precautions

- applications, xx
- general, xviii
- handling precautions, 50
- operating environment, xix
- safety, xviii

process value

- automatic scaling, 8, 367
- averaging, 13

process value alarm, 9, 365

pulse accumulation, 18

pulse input instantaneous value conversion, 17

R

rate-of-change alarm, 10, 365

rate-of-change limit, 18

Restart Bits, 36, 40, 43

restarting Special I/O Units, 36, 43

S

safety precautions

- See also* precautions

scaling, 8, 367

- setup
 - initial hardware setup, 55
 - initial software setup, 55
 - span adjustment gain, 16
 - example, 375
 - specifications, 26
 - CJ1W-PDC15, 325
 - CJ1W-PH41U, 341
 - CJ1W-PTS15, 290
 - CJ1W-PTS16, 314
 - CJ1W-PTS51, 278, 341
 - CJ1W-PTS52, 303
 - CS1W-PDC01, 191
 - CS1W-PDC11, 203
 - CS1W-PDC55, 219
 - CS1W-PMV01, 260
 - CS1W-PMV02, 269
 - CS1W-PPS01, 249
 - CS1W-PTR01, 230
 - CS1W-PTR02, 240
 - CS1W-PTS01-V1, 70
 - CS1W-PTS02, 124
 - CS1W-PTS03, 134
 - CS1W-PTS11, 83
 - CS1W-PTS12, 145
 - CS1W-PTS51, 99
 - CS1W-PTS52, 158
 - CS1W-PTS55, 111
 - CS1W-PTS56, 168
 - CS1W-PTW01, 178
 - square root, 15, 372
 - stepdown rate, 17
 - system configuration, 24
 - CJ1W-PDC15, 324
 - CJ1W-PH41U, 338
 - CJ1W-PTS15, 288, 338
 - CJ1W-PTS16, 312
 - CJ1W-PTS51, 276
 - CJ1W-PTS52, 302
 - CS1W-PDC01, 189
 - CS1W-PDC11, 200
 - CS1W-PDC55, 218
 - CS1W-PMV01, 258
 - CS1W-PMV02, 267
 - CS1W-PPS01, 247
 - CS1W-PTR01, 229
 - CS1W-PTR02, 238
 - CS1W-PTS01-V1, 68
 - CS1W-PTS02, 121
 - CS1W-PTS03, 132
 - CS1W-PTS11, 80
 - CS1W-PTS12, 142
 - CS1W-PTS51, 97
 - CS1W-PTS52, 157
 - CS1W-PTS55, 109
 - CS1W-PTS56, 167
 - CS1W-PTW01, 177
- T**
- terminals
 - connecting, 52
- U**
- unit number switches, 31, 33
- V**
- variable input range setting, 7
- W**
- word allocation, 34
 - CJ1W-PDC15, 328, 331
 - CJ1W-PH41U, 349, 355
 - CJ1W-PTS15, 293, 296
 - CJ1W-PTS16, 316, 318
 - CJ1W-PTS51, 281, 283
 - CJ1W-PTS52, 307, 308
 - CS1W-PDC01, 193, 195
 - CS1W-PDC11, 205, 209
 - CS1W-PDC55, 221, 225
 - CS1W-PMV01, 262, 263
 - CS1W-PMV02, 271, 272
 - CS1W-PPS01, 252, 253
 - CS1W-PTR01, 232, 234
 - CS1W-PTR02, 241, 243
 - CS1W-PTS01-V1, 73, 75
 - CS1W-PTS02, 126, 128
 - CS1W-PTS03, 136, 138
 - CS1W-PTS11, 86, 90
 - CS1W-PTS12, 147, 150
 - CS1W-PTS51, 103, 104
 - CS1W-PTS52, 161, 163
 - CS1W-PTS55, 114, 117
 - CS1W-PTS56, 171, 174
 - CS1W-PTW01, 181, 183

Z

zero adjustment offset, 16
example, 375

Revision History

A manual revision code appears as a suffix to the catalog number on the front cover of the manual.

Cat. No. W368-E1-09

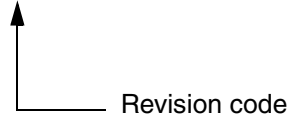

The following table outlines the changes made to the manual during each revision. Page numbers refer to the previous version.

| Revision code | Date | Revised content |
|---------------|---------------|--|
| 1 | April 2000 | Original production |
| 02 | January 2002 | <p>“CS1 Series” was changed to “CS Series” and “-V1” was added to the model number CS1W-PTS01 throughout the manual. In addition, the following changes were made.</p> <p>Page 39: Changes made to diagram and notes 1 and 2, and another note added.</p> <p>Page 40: Terminal numbers changed</p> <p>Page 128: Changes made to equations in 3 places.</p> |
| 03 | May 2002 | Information on the CS1W-PMV02 Isolated-type Analog Output Unit was added throughout the manual. |
| 04 | August 2003 | <p>“PC” was changed to “PLC” throughout the manual.</p> <p>Changes and additions were made to add the CS1W-PTS11, CS1W-PTS12, and CS1W-PDC11.</p> |
| 05 | February 2004 | Changes and additions were made to add the CS1W-PTS51/PTS52 and CJ1W-PTS51/PTS52. |
| 06 | June 2004 | Changes and additions were made to add the CS1W-PTS55/PTS56 and PDC55. |
| 07 | March 2005 | Changes and additions were made to add the CJ1W-PTS15/PTS16 and PDC15. |
| 08 | February 2007 | <p>Page v: Added information on notation for general precautions.</p> <p>Page x: Added information on liability and warranty.</p> <p>Page 13: Added a note below the bottom table.</p> <p>Page 23: Added maximum current and total power supplied for the C200HW-PD025 and CS1D-PD025.</p> <p>Pages 55, 93, 152, 271, and 297: Changed the default values for m+4 to m+16.</p> <p>Page 162: Changed word to m+34 in bottom table.</p> <p>Pages 194 and 317: Added “output =” to formula and added “for” to note 2.</p> <p>Pages 196 and 319: Changed the decimal data range for m+38, m+39, m+42, and m+43.</p> <p>Page 210: Added information on input range to square root calculation and modified the equation.</p> <p>Page 211: Changed values for m+4 to m+32.</p> <p>Page 212: Added information on input range for the square root function, changed the decimal data range for m+39 and m+40, and removed setting of 00 to 03 from m+34.</p> <p>Page 213: Modified the description below the table.</p> <p>Page 283: Added “8: mV” to the sensor type for m+34 and m+49.</p> <p>Pages 290 and 312: Added 24-VDC circuit to the top diagram.</p> |
| 09 | March 2008 | Changes and additions were made to add the CJ1W-PH41U Isolated-type Universal Input Unit. |